



## Catalogue

---

# Equipment for Hydrogen Peroxide Service





---

# CONTENTS

## Equipment for Hydrogen Peroxide Service

### Catalogue

---

500mm Ultra Low Profile Manlid Assembly	3
250mm Low Profile Burst Disc Holder	5
2½" BSP Super Maxi Relief Valve	7
50mm Low Profile Breather Vent	9
50mm Ball Valve	11
Blind Weld-in Flange	13
<b>Appendix</b>	
Bolt Torque Guide & Step Loading Procedure	17
Client Responsibilities	19
Fort Vale Worldwide	21





# 500mm Ultra Low Profile Manlid Assembly: H<sub>2</sub>O<sub>2</sub>

Part No: E4X-85XX013A

## Specification

### Nominal size

DN500

### Cover

8 point with a fill pipe flange assembly & a breather vent assembly with sintered disc and low-leak cap with secondary sintered disc

### Neckring/compensating ring

Thickness: 8mm

Tank radius profiling range: 950mm to 1260mm

### Materials

Contact parts: 316 stainless steel

Fasteners: stainless steel swingbolts and handnuts

Fill pipe gasket & breather vent seals: PTFE

Manlid cover seal: supplied separately

Alternatives are available, refer to Fort Vale



## Design Conditions

Weight:	57.8 Kg
Design Pressure (MAWP):	4 Bar
Test Pressure:	6 Bar
Design Temperature Min:	-40°C
Design Temperature Max:	200°C

**NOTE:** The Design Temperature limits refer to metal parts only. The Design Conditions and Section View dimensions are for the specified part number only.

### Design Codes

BS EN 14025

## Section View

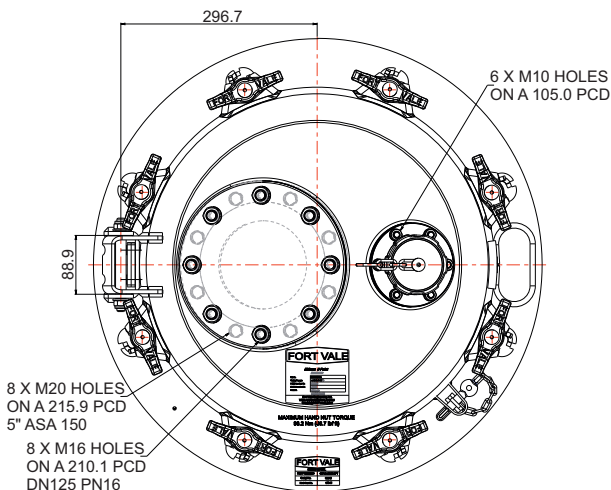
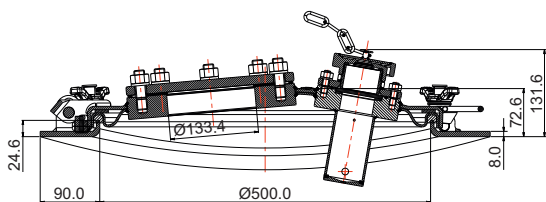



# 500mm Ultra Low Profile Manlid Assembly: H<sub>2</sub>O<sub>2</sub>

Part No: E4X-85XX013A

## Parts Drawing

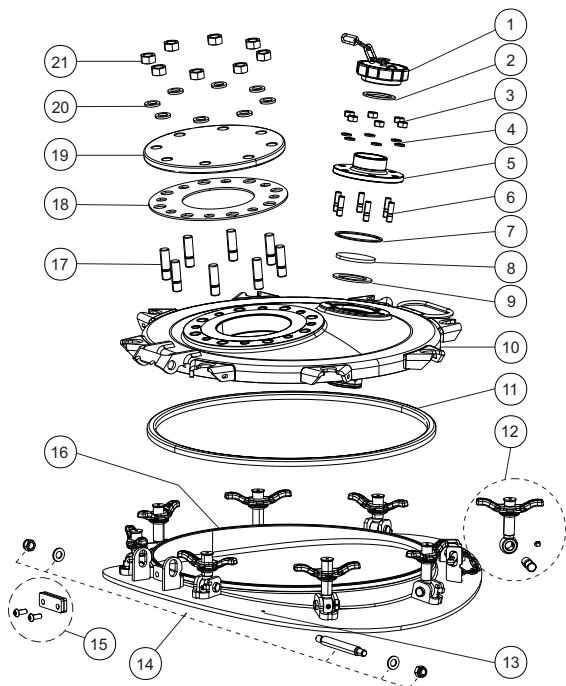

## Parts List

Item	Description	Part No.
1	Breather cap assembly	674/3040
2	Breather cap seal	5005-414
3	M10 full nut (6)	5112-002
4	M10 spring washer (6)	5113-002
5	2" BSP outlet	674/3546
6	M10 x 35mm stud (6)	371/0001
7	PTFE O ring	5005-235
8	Sintered disc	865/2000
9	PTFE gasket	5005-435
10	Manlid cover	74E/0550T
11	Seal (not included) *Note	5005-XXXX
12	Short swingbolt assy. (4)	496/5250
	Long swingbolt assy. (4) *Note	496/5XXX
13	M6 set screw	5111-009
14	Hinge pin assembly	600/1060
15	Hinge kit *Note	135B
16	Neckring *Note	6EP/7403XXXPT
17	M16 x 60mm stud (8)	368/1109
18	PTFE fill flange gasket	5005-411
19	Blind flange	674/5051
20	M16 spring washer (8)	5113-012
21	M16 full nut (8)	5112-003

**NOTE:** The specification changes the Part No.



# 250mm Low Profile Burst Disc Holder: Hydrogen Peroxide

Part No: 674/8680



## Specification

### Nominal size

250mm

### Tank connection

Flanged: 12 x M20 holes on a 350.0mm PCD

### Properties

Weather cowl, TIR and internal surge protection cover.

**NOTE:** The burst disc is not included, refer to Related Parts

### Materials

Weld-in flange: 316L stainless steel

Gasket: PTFE

Alternatives are available, refer to Range or contact Fort Vale

## Design Conditions

Weight:	38.7 Kg
Design Pressure (MAWP):	4 Bar
Design Temperature Max:	140°C
Minimum Flow:	93045 m <sup>3</sup> /hr at 4 Barg

**NOTE:** The Design Conditions and Section View dimensions are for the specified part number only.

## Range

Description	Part No.
With surge protection cover	674/8680
Without surge protection cover	674/8580

## Related Parts

Description	Part No.
250mm burst disc: 4.5 Bar at 20°C	865/A0450020AD
250mm burst disc: 4.5 Bar at 60°C	865/A0450060AD
250mm burst disc: 6 Bar at 20°C	865/A0600020AD

## Section View

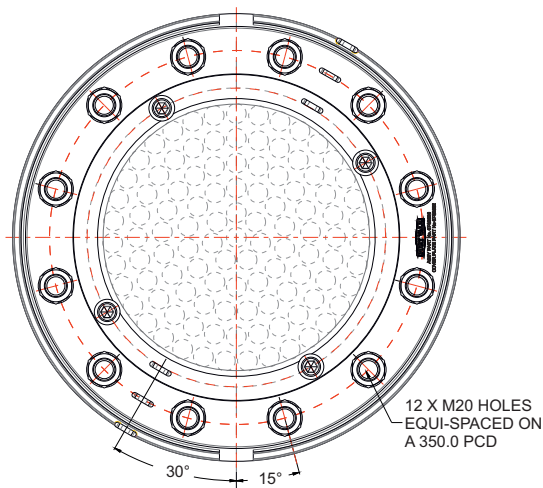
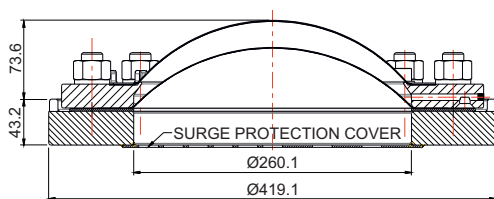



# 250mm Low Profile Burst Disc Holder: Hydrogen Peroxide

Part No: 674/8680

## Parts Drawing

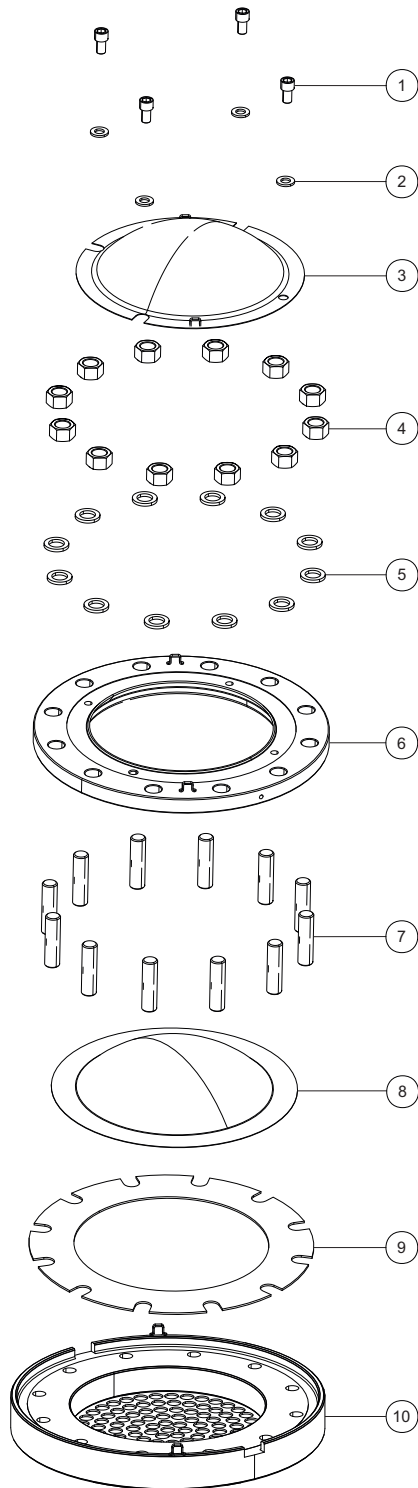

## Parts List

Item	Description	Part No.
1	M12 cap screw (4)	5111-066
2	M12 plain washer (4)	5113-006
3	Weather cowl	674/2005
4	M20 full nut (12)	5112-011
5	M20 spring washer (12)	5113-016
6	Burst disc cover plate	674/2002
7	M20 stud (12)	674/8005
8	Burst disc <b>*Note</b>	865/XXXX
9	PTFE gasket	5005-283
10	Weld-in flange with surge cover	674/8560

**NOTE:** The burst disc is supplied as a separate part. Please refer to Related Parts, page 1.





# 2½” BSP Super Maxi Relief Valve - Pressure/Vacuum

Part No: 010/1XXXXX - Metric Setting



## Specification

### Nominal size

DN65

### Tank connection

2½” BSP

### Set pressure

From 0.15 Bar to 5.15 Bar

### Set vacuum

From 1 kPa to 88 kPa

### Materials

Contact parts: 316 stainless steel

Pressure O ring: Fortyt

Vacuum O ring: Fortyt

Tank seal: Rubber/PTFE envelope

Alternatives are available, refer to the Design Options page

## Design Conditions

Weight:	2.9 Kg
Design Pressure (MAWP):	5.2 Bar
Test Pressure:	10.1 Bar
Design Temperature Min:	-55°C
Design Temperature Max:	200°C

**NOTE:** The working temperature of the pressure and vacuum O rings can change the design temperature limits. The Design Conditions and Section View dimensions are for the specified part number only.

### Approval

Design Approval by Lloyds Register of Shipping

**WARNING:** If you install an approved relief valve accessory item, e.g. a flame arrester, cowl, burst disc or baffle, it will decrease the air flow capacity of the relief valve. Thus, you must calculate again to make sure that the decreased air flow capacity will give sufficient protection to your vessel/system. Refer to Fort Vale for more information.

## Range

Standard Settings	Part No.
2.19 Bar & 21 kPa	010/121921
3.31 Bar & 21 kPa	010/133121
3.71 Bar & 21 kPa	010/137121
4.40 Bar & 21 kPa	010/144021

## Related Parts

Description	Part No.
2½” BSP weld-in socket	600/1000
Tank weld-in flange	176/3150
CNAF/PTFE gasket (adaptor flange)	5005-398
0-7 Bar pressure gauge, brass internal parts	921/07BBSP
0-7 Bar pressure gauge, stainless steel internal parts	920/07BBSP
Flame arrester <b>*Warning</b>	176/2900
Gauzed cowl <b>*Warning</b>	176/6000

## Section View

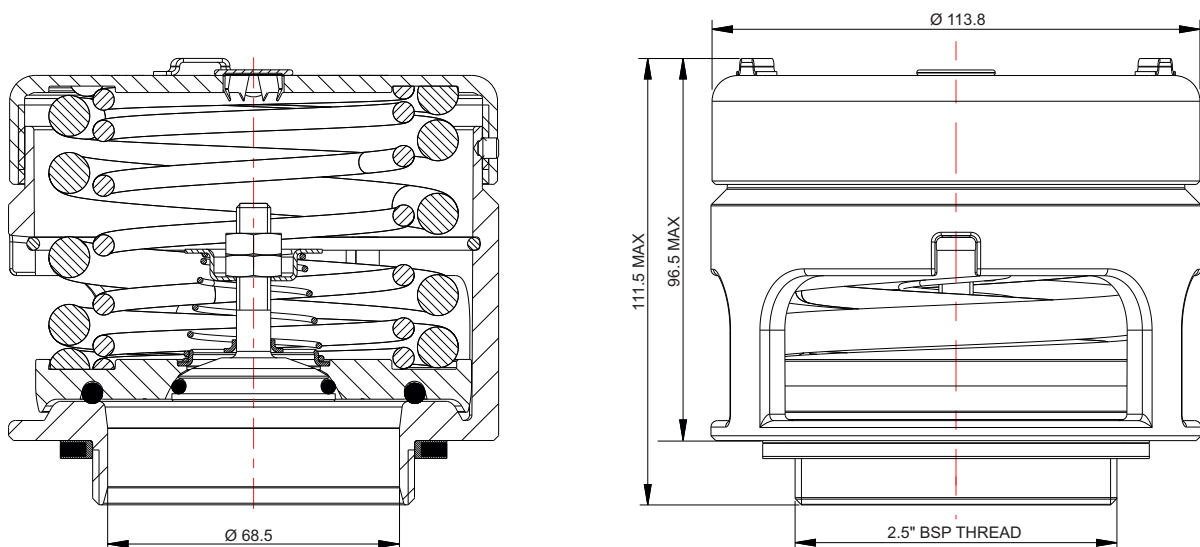



# 2 1/2" BSP Super Maxi Relief Valve - Pressure/Vacuum

Part No: 010/1XXXXX - Metric Setting

## Parts Drawing

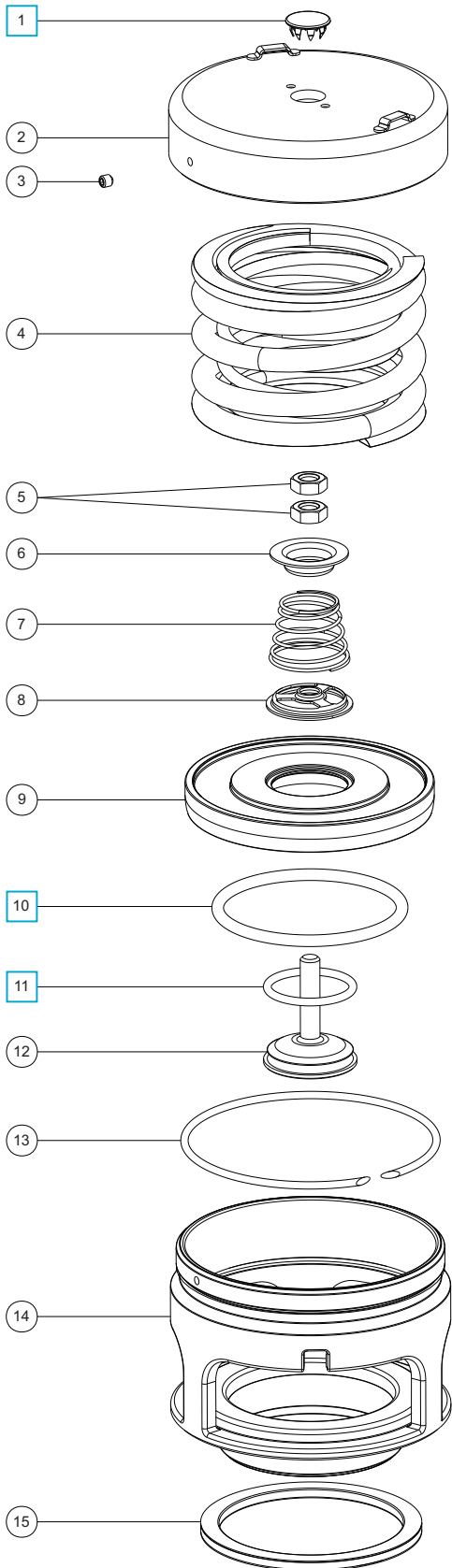

## Parts List

Item	Description	Part No.
1	Stainless steel plug	10978 <input type="checkbox"/>
2	Cap *Note	1760/0005XX
3	Anti-tamper screw	5121-001
4	Pressure springs	Refer to Table 1
5	M8 half nut (2)	5112-004
6	Vacuum spring pad	1860/0005
7	Vacuum spring	Refer to Table 2
8	Spring pad	10986/3
9	Pressure plate *Note	1860/005XXX
10	Fortyt pressure O ring	5005-101 <input type="checkbox"/>
11	Fortyt vacuum O ring	5005-108H <input type="checkbox"/>
12	Vacuum poppet	10983V/3
13	Retaining ring clip	5120-067
14	Body	1860/0100
15	Rubber/PTFE envelope seal	5005-046

**NOTE:** The valve specification changes the Part No.

## Table 1

Std. Pressure Settings	Pressure Spring Part No.
2.19 Bar	6104-0252
3.31 Bar	6104-0112 & 6104-0252
3.71 Bar	6104-0422 (Pair)
4.40 Bar	6104-0485 (Pair)

Pressure springs are available from 0.15 Bar to 5.15 Bar

## Table 2

Std. Vacuum Setting	Vacuum Spring Part No.
21 kPa	7104-012

Vacuum springs are available from 1 kPa to 88 kPa

## Seal Kit

Description	Part No.
All parts marked <input type="checkbox"/> in the Parts List	000/1PVSK



# 50mm Low Profile Breather Vent: Hydrogen Peroxide

Part No: 674/3542



## Specification

### Nominal size

50mm

### Tank connection

Flanged: 6 x 11mm holes on a 104.9mm PCD

### Outlet connection

2" BSP

### Properties

With sintered disc to prevent vessel pressurisation  
Low-leak cap with secondary sintered disc and chain

### Materials

Contact parts: 316 stainless steel  
Sintered discs: 316 stainless steel  
All seals & gaskets: PTFE

Alternatives are available, refer to Range or contact Fort Vale

## Design Conditions

Weight: 5.29 Kg  
Design Pressure (MAWP): 4 Bar  
Design Temperature Min: -40°C  
Design Temperature Max: 150°C

**NOTE:** The Design Conditions and Section View dimensions are for the specified part number only.

### Approvals

The cap is compatible with SNCF regulations

## Range

Description	Part No.
Weld-in breather vent assembly	674/3500
DIN80 PN10 flanged breather vent assy	674/3550

## Related Parts

Description	Part No.
Weld-in flange	176/3150

## Section View

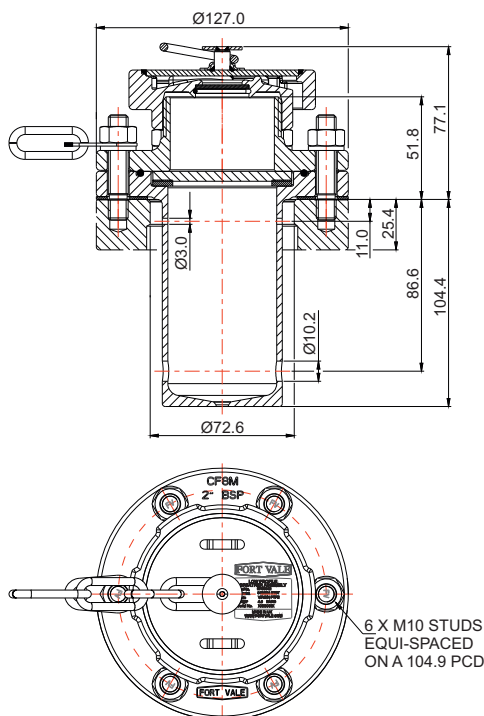



# 50mm Low Profile Breather Vent: Hydrogen Peroxide

Part No: 674/3542

## Parts Drawing

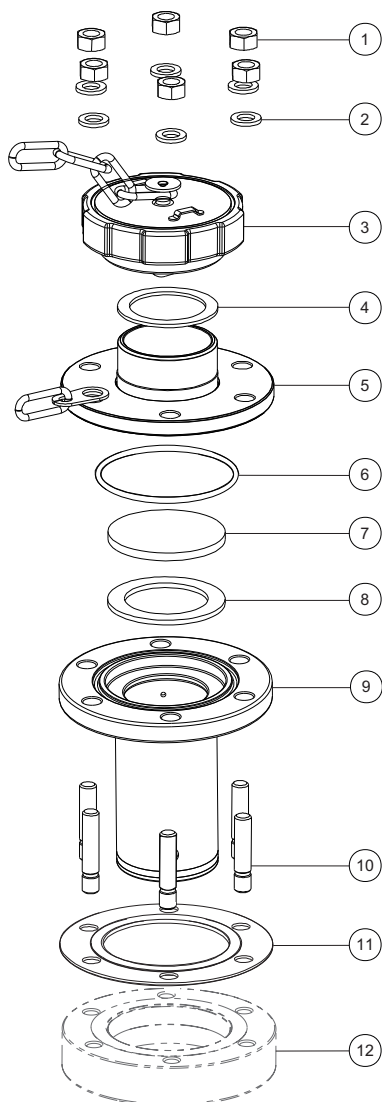

## Parts List

Item	Description	Part No.
1	M10 full nut (6)	5112-002
2	M10 spring washer (6)	5113-002
3	Breather cap assembly	674/3040
4	PTFE breather cap seal	5005-414
5	2" BSP outlet	674/3546
6	PTFE O ring	5005-235
7	Sintered disc	865/2000
8	PTFE breather disc seal	5005-435
9	Breather body	674/3540
10	M10 x 53mm stud (6)	371/0008-B8
11	PTFE inlet gasket	5005-398P
12	Weld-in flange (supplied separate)	176/3150



# 2" Ball Valve: Hydrogen Peroxide Specification

Part No: 370/0140



## Specification

### Nominal size

50mm

### Tank connection

Flanged: 6 x 14mm holes on a 168mm PCD

### Outlet/Process connection

Flanged: 4 x open slots - 2" ASA150 / 2" BSTD / DIN50 PN10

### Properties

Ball with bleed hole and body with gauge connection to monitor tank pressure. Handle with TIR. With blind flange

### Materials

Contact parts: 316 stainless steel

Main seal: PTFE

Alternative tank connections are available, refer to Fort Vale

## Design Conditions

Weight:	13.5 Kg
Design Pressure (MAWP):	7.5 Bar
Test Pressure:	13.8 Bar
Design Temperature Min:	-40°C
Design Temperature Max:	205°C

**NOTE:** The Design Conditions and Section View dimensions are for the specified part number only.

### Design Code

BS EN14432

## Related Parts

Description	Part No.
Tank weld-in flange	368/0800
Stud kit	312/1000
Solid PTFE inlet gasket	5005-222P
Syphon tube stub pipe	368/0810
CNAF/PTFE gasket	5005-169

## Section View

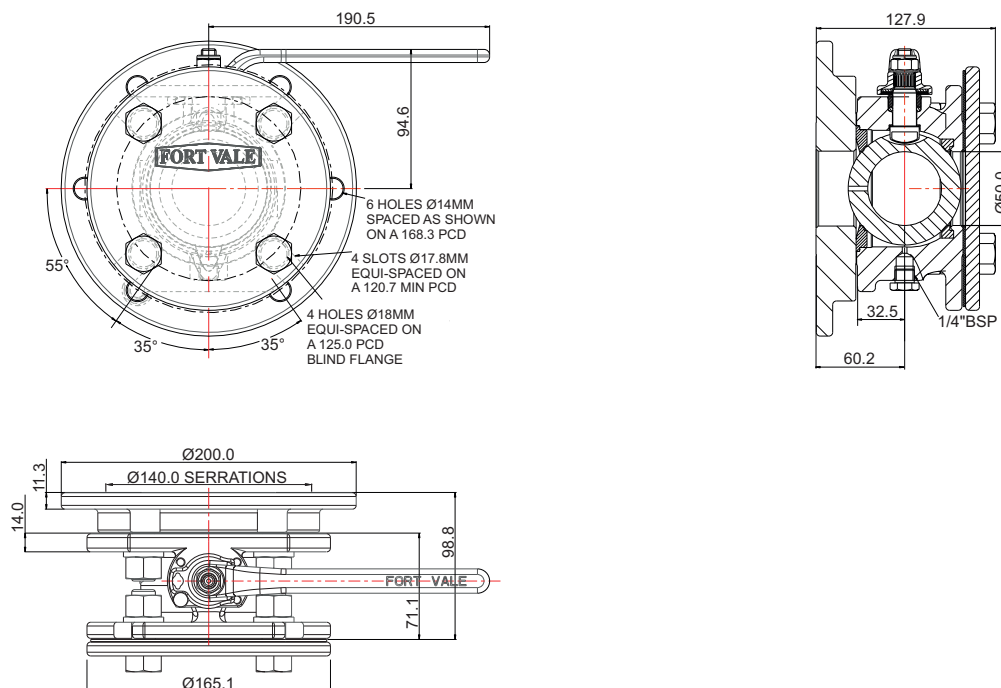



# 2" Ball Valve: Hydrogen Peroxide Specification

Part No: 370/0140

## Parts Drawing

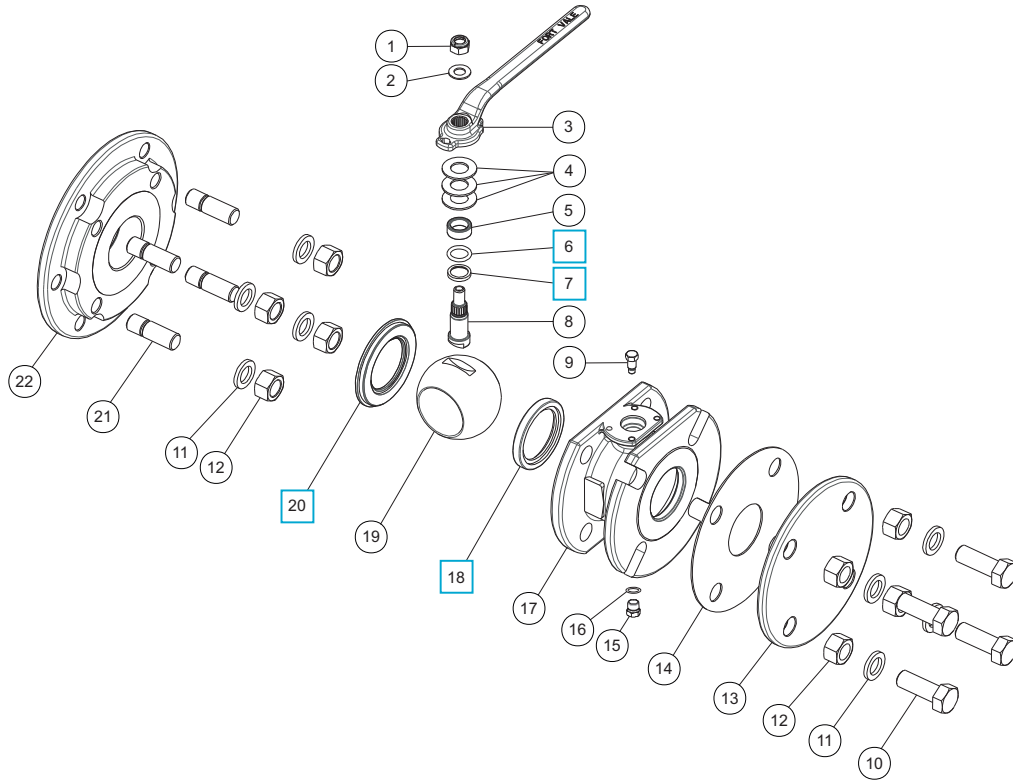

### Parts List

Item	Description	Part No.	
1	M10 self locking nut	5112-008	
2	M10 plain washer	5113-009	
3	Handle	370/0125	
4	16mm Belleville washer (3)	5113-038	
5	Stuffing collar	370/0103	
6	PTFE O ring	5005-688	□
7	Bottom bearing bush	370/0104	□
8	Spindle	370/0120	
9	Stop bolt	370/0107	
10	M16 hex bolt (4)	5111-031	
11	M16 spring washer (8)	5113-012	
12	M16 full nut (8)	5112-003	
13	Blind flange	370/4239	
14	PTFE gasket	5005-724P	
15	1/4" BSP hex plug	5128-005	
16	PTFE O ring	5005-048	
17	2" ball valve body	370/0115	
18	PTFE ball seal	370/0102	□
19	2" ball	370/3309	
20	PTFE ball seal	370/0105	□
21	M16 stud (4)	S0600/3	
22	Adaptor flange	370/0145	

### Seal Kit

Description	Part No.
All parts marked <span style="border: 1px solid blue; padding: 0 2px;"> </span> in the Parts List	370/01SK



# Blind Weld-in Flange: Hydrogen Peroxide

Part No: 324/9007



## Specification

The blind weld-in flange is welded into the bottom of the vessel in the normal discharge valve position. If the vessel is changed to standard service, the centre section of the flange can be cut out so that a 45° discharge valve assembly can be installed.

### Drilling pattern

8 x M12 holes equi-spaced on a 178mm PCD

### Compatible

Standard 45° Cleanflow, Uniflow, Highlift & Univalve footvalves

### Material

316 stainless steel

## Design Conditions

Weight	4.5 Kg
Design Pressure (MAWP):	6.67 Bar
Test Pressure:	10.0 Bar
Design Temperature Min:	-40°C
Design Temperature Max:	130°C

NOTE: The Design Conditions and Section View dimensions are for the specified part number only.

## Section View

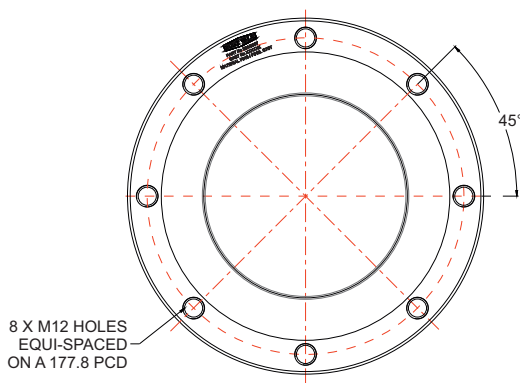
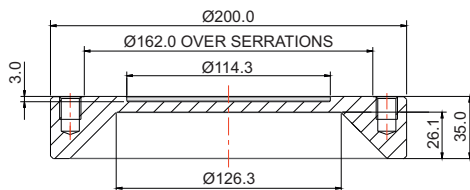







---

# APPENDIX

## Catalogue

---

---

A	Bolt Torque Guide & Step Loading Procedure
B	Client Responsibilities - Valves & Accessories

---





# Bolt Torque Guide & Step Loading Procedure

## Installation & Operating Instructions

### Flange Bolting

**CAUTION:** Weld-distortion and too much tightening force will cause damage to a flange.

It is important not to cause damage to weld-in flanges and mating flanges. If a flange is damaged it will not give a satisfactory seal when a gasket and secondary mating flange is installed.

Bolt-stress can decrease after initial tightening. The cause can be deformation of the gasket material, particularly with soft materials such as a CNAF/PTFE envelope gasket.

Best procedure recommends that, after initial bolting, the flange joint is tightened again after a period of time. Most gasket manufacturers advise a period of 24 hours. ASME PCC-1-2000 GUIDELINES FOR PRESSURE BOUNDARY BOLTED FLANGE JOINT ASSEMBLY advises a minimum period of 4 hours.

Bolt torque calculations are based on a flat flange to within 0.15mm.

Recommended bolt torque values will be reduced if a lubrication is used.

### Bolt Torque

#### Bolt Torque Values

Fort Vale bolt torque values are given as a reference guide only and are based on:

- the use of a CNAF/PTFE gasket.
- unlubricated fasteners.
- a flange flat to within 0.15mm.

**CAUTION:** If you use a different gasket material, a lubricant or a flange with distortion, you must re-calculate the torque value.

#### Bolt Torque Procedure

To install flanged parts correctly:

- Examine the mating flange of the part.
- If the flange is marked with a torque value, obey that torque value.
- If there is no torque value marked on the mating flange, obey the bolt torque values given in Table BT1.
- Tighten the bolts evenly in sequence. Refer to Figure BT1.
- Obey the Step Loading Procedure (ASME PCC-1-2000). Refer to the next page.

Table BT1

Thread	Torque Value
M10	30 Nm (22 lbf.ft)
M12	65 Nm (48 lbf.ft)
M16	81 Nm (60 lbf.ft)

Figure BT1

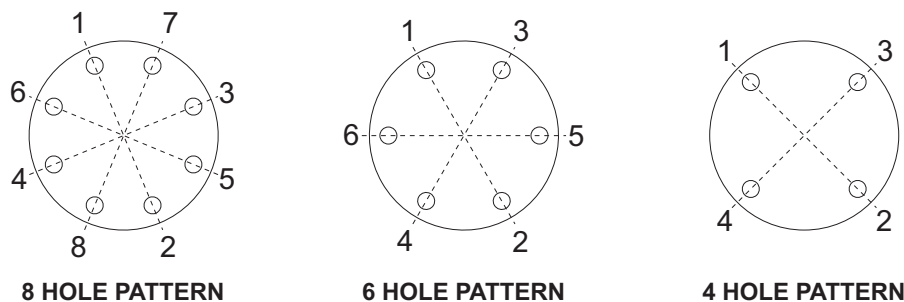



# Bolt Torque Guide & Step Loading Procedure

## Installation & Operating Instructions

---

### Step Loading Procedure

To install flanged parts correctly, obey the Step Loading Procedure extract from ASME PCC-1-2000:

#### Install

Hand tighten, then “snug up” to 15 Nm (10 lbf.ft) to 30 Nm (20 lbf.ft) (not to exceed 20% of Target Torque). Check flange gap around circumference for uniformity. If the gap around the circumference is not reasonably uniform, make the appropriate adjustments by selective tightening before proceeding.

#### Round 1

Tighten to 20% to 30% of Target Torque. Check flange gap around circumference for uniformity. If the gap around the circumference is not reasonably uniform, make the appropriate adjustments by selective tightening before proceeding.

#### Round 2

Tighten to 50% to 70% of Target Torque. Check flange gap around circumference for uniformity. If the gap around the circumference is not reasonably uniform, make the appropriate adjustments by selective tightening before proceeding.

#### Round 3

Tighten to 100% of Target Torque. Check flange gap around circumference for uniformity. If the gap around the circumference is not reasonably uniform, make the appropriate adjustments by selective tightening before proceeding.

#### Round 4

Continue tightening the bolts, but on a rotational clockwise pattern until no further nut rotation occurs at the Round 3 Target Torque value. For indicator bolting, tighten bolts until the indicator rod retraction readings for all bolts are within the specified range.

#### Round 5

Time permitting, wait a minimum of 4 hr and repeat Round 4; this will restore the short-term creep relaxation/embedment losses. If the flange is subjected to a subsequent test pressure higher than its rating, it may be desirable to repeat this round after the test is completed.



## Client Responsibilities - Valves & Accessories

### Installation, Operation & Maintenance Instructions

## Compatibility

Make sure that the function and technical specification of the valve/accessory is compatible with the vessel service conditions and the cargo. This includes, but is not limited to:

- dimensions.
- pressure/vacuum setting.
- air/vapour/liquid flow capacity.
- maximum allowable working pressure.
- test pressure.
- minimum/maximum design temperatures.
- materials of construction.

## Maintenance and Inspection

Fort Vale valves and accessories have a long life if you use them correctly in compatible service conditions. It is not necessary to lubricate the parts, but we recommend that you do the inspections that follow:

### Inspections at regular intervals:

1. Examine the valve to make sure there is no damage, wear or corrosion.
2. Examine the valve and adjacent area to make sure there is no leakage of cargo.
3. Examine the fasteners to make sure they are not loose.
4. Make sure the valve operates correctly.

**CAUTION:** If you operate the valve with very corrosive cargo, or near its temperature and/or pressure limit (very high or very low temperature and/or pressure), do the inspections more frequently.

Also, schedule regular maintenance based on how frequently the valve is used, the type of cargo and the service conditions.

### Inspections after 2½ years of service or a minor incident:

1. Examine the valve to make sure there is no damage, wear or corrosion.
2. Make sure the valve operates correctly.
3. Do a pressure test on the valve.

### Inspections after 5 years of service or a major incident:

1. Disassemble and clean the valve.
2. Replace all the valve seals and do a pressure test.

## Replacement Parts

Do not adapt or change the valve. If you install a replacement part, it must be a genuine Fort Vale part.

**WARNING:** If you install a part that is not genuine, there is a risk of:

- injury to personnel.
- permanent damage to the valve.
- permanent damage to the vessel.
- valve malfunction.

## External Fire

If you install the valve in an area where there is a risk of external fire, you must install compatible accessories to prevent damage to the valve.

## Compatibility of Accessories

Accessory components must cause no interference with the valve's function. Accessories must be made from compatible materials that will cause no damage to the valve materials. Do not install an accessory that will cause an increased load on the valve, such as mechanical, static, dynamic or thermal load.

## Mis-use

Obey the instructions and recommended procedures in the installation and operating instructions. Obey the pressure and temperature markings on the valve and on the drawing. Use the valve/accessory for its correct function only. Fort Vale accept no liability or responsibility for incorrect use of the valve/accessory.





Our subsidiaries are located in:

**US Office**

126 N. Virginia  
La Porte  
TX 77571  
USA

Tel: +1 281 471 8100

Fax: +1 281 471 8116

Email: [ussales@fortvale.com](mailto:ussales@fortvale.com)

**Head Office**

Calder Vale Park  
Simonstone Lane  
Simonstone, Burnley  
Lancashire, BB12 7ND, UK

Tel: +44 (0) 1282 687120

Fax: +44 (0) 1282 687110

Email: [sales@fortvale.com](mailto:sales@fortvale.com)

**China Office**

Fort Vale Engineering Shanghai Ltd  
Building 11 88 Yuanshan Road  
Xinzhuang Industry Park  
Shanghai 201108 China

Tel: +86 21 6442 1367

Fax: +86 21 6442 1376

Email: [cnsales@fortvale.com](mailto:cnsales@fortvale.com)

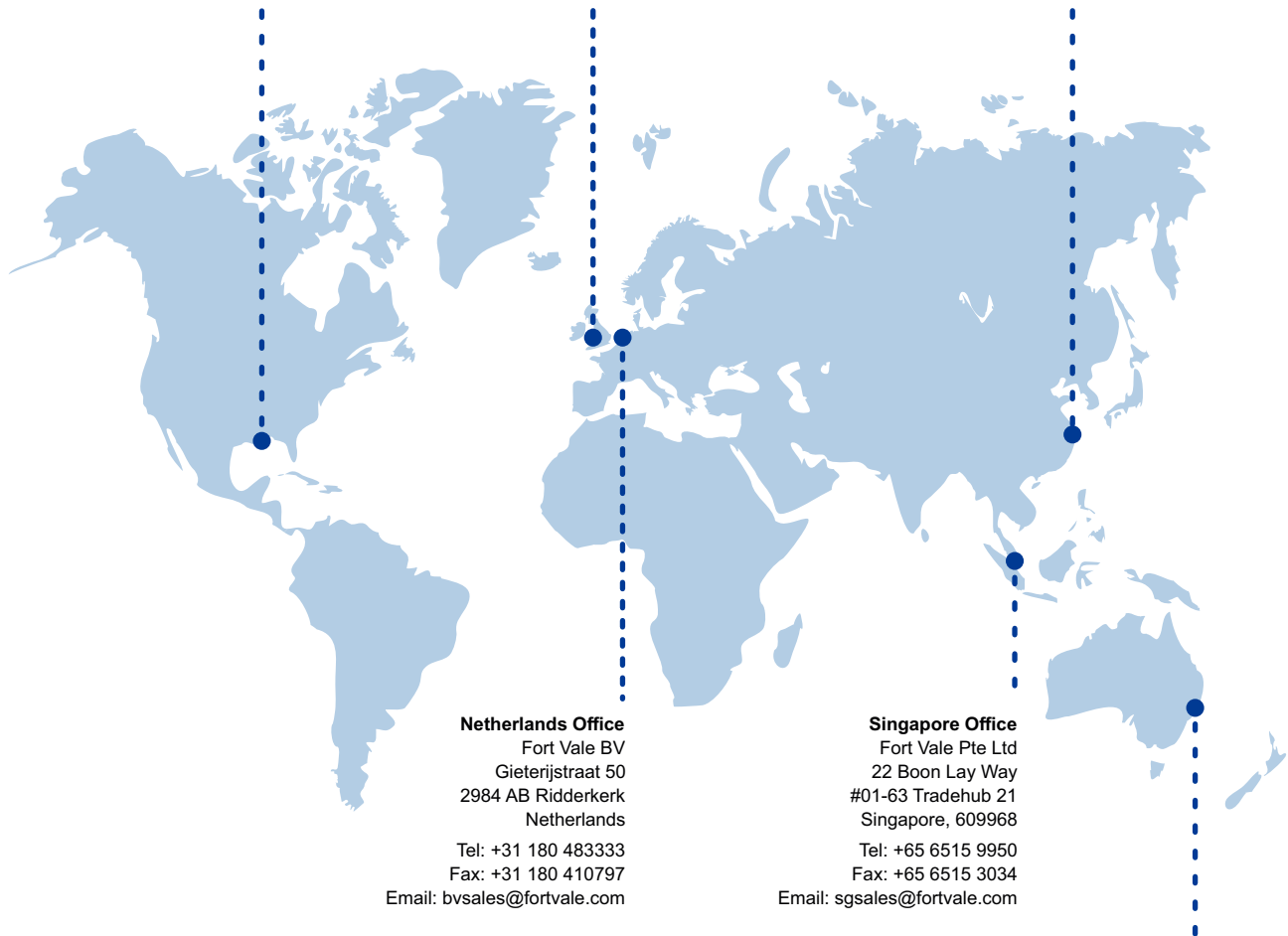

**Netherlands Office**

Fort Vale BV  
Gieterijstraat 50  
2984 AB Ridderkerk  
Netherlands

Tel: +31 180 483333

Fax: +31 180 410797

Email: [bvsales@fortvale.com](mailto:bvsales@fortvale.com)

**Singapore Office**

Fort Vale Pte Ltd  
22 Boon Lay Way  
#01-63 Tradehub 21  
Singapore, 609968

Tel: +65 6515 9950

Fax: +65 6515 3034

Email: [sgsales@fortvale.com](mailto:sgsales@fortvale.com)

**Australia Office**

Fort Vale Australia Pty Ltd  
Bellwood Business Park  
Unit 14, 49 Bellwood Street  
Darra, Queensland, 4076

Tel: +61 7 3189 5059

Email: [ausales@fortvale.com](mailto:ausales@fortvale.com)

We also have Authorised Distributors around the world to provide you with product sales and after-market services. To find your nearest distributor, please visit our website - [www.fortvale.com](http://www.fortvale.com)

