



## Catalogue

# Standard Range of Manlid & Inspection Hatch Assemblies





# CONTENTS

## Manlid & Inspection Hatch Assemblies

### Catalogue

|  |    |
|--|----|
| Design Options: Manlid & Inspection Hatch Assemblies                                 | 3  |
| <b>Inspection Hatch Assemblies</b>   |    |
| 170mm Inspection Hatch Assembly  | 5  |
| 300mm Inspection Hatch Assembly  | 7  |
| 300mm Ultra Low Profile Inspection Hatch Assembly                                    | 9  |
| <b>Manlid Assemblies</b>   |    |
| 460mm Pendle Manlid Assembly   | 11 |
| 500mm Low Pressure Pendle Manlid Assembly  | 13 |
| 500mm Pendle Manlid Assembly   | 15 |
| 500mm Ultra Low Profile Pendle Manlid Assembly                                       | 17 |
| 500mm Ultra Low Profile Manlid Assembly: H <sub>2</sub> O <sub>2</sub> Specification | 19 |
| 500mm Manlid Assembly with Quick Release Latches                                     | 21 |
| 600mm Manlid Assembly  | 23 |
| <b>Elliptical Manlid Assemblies</b>  |    |
| Elliptical Manlid Assembly - Low Profile Neckring                                    | 25 |
| Elliptical Manlid Assembly - Deep Neckring   | 27 |

Continued over



---

# CONTENTS

## Manlid & Inspection Hatch Assemblies

### Catalogue

---

#### Accessories: Fasteners

|                      |    |
|----------------------|----|
| Safebolt Assembly    | 29 |
| Swingbolt Assemblies | 31 |

#### Accessories: Seals

|   |    |
|---|----|
| Introduction                                  | 35 |
| Braided Packing                               | 37 |
| Composite Seals                               | 38 |
| Elastomer Seals                               | 39 |
| How to Install a Manlid/Inspection Hatch Seal | 40 |

#### Appendix

|   |    |
|---|----|
| Handnut Torque Guide - Hinged Manlid Assemblies     | 43 |
| Client Responsibilities - Manlid/Inspection Hatches | 44 |
| Fort Vale Worldwide                                 | 45 |





# Manlid & Inspection Hatch Assemblies

## Design Options

### Function

A manlid assembly or inspection hatch assembly is usually installed on the top of the tank. A manlid assembly is used to give access to personnel to let them examine, repair or clean the inside of the tank. An inspection hatch is used for access to take a sample of cargo and can also be used as access for cleaning equipment.

### Design Options

The design options below are available on our standard range of hinged circular manlid and inspection hatch assemblies. We can deliver manlids and inspection hatches assembled or disassembled.

#### Nominal Diameter

**Inspection Hatch:**  
170mm, 300mm

**Manlid:**  
460mm, 500mm, 600mm



#### Design Pressure: MAWP

From 0 Bar to 4 Bar

**Special service conditions:**  
> 4 Bar

#### Opening Angle

120°: Fixed or liftover

135°: Fixed or liftover



#### Fixing Points

3, 4, 6, 8 points

**Special service conditions:**  
Single point, 10 points

#### Neckring / Compensating Ring

**Height:** From ultra-low to extended

**Profile:** Straight (no profile) or profiled compatible with the tank radius

**Compensation:** With or without compensating ring

**Material thickness:** 6mm, 8mm or compatible with the MAWP and the tank shell thickness



#### Swingbolt Assemblies

**Eyebolt:** stainless steel

**Handnut:** naval brass - low profile; stainless steel - low profile or extended, with/without brass insert

**Special service conditions:**  
Safebolt assembly (at one point)

Hexagonal nuts

Bow nuts

Single arm handnuts

Quick release latches

With locknuts

#### Material

Contact parts: 316 stainless steel

**Special service conditions:**  
304 stainless steel

High nickel alloys

Carbon steel: Neckring only

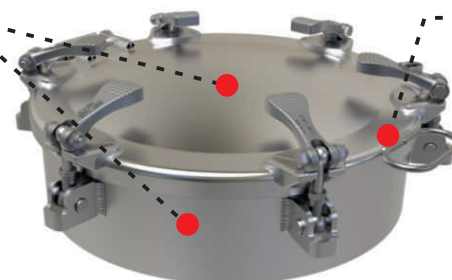

#### Seal

A large range of seal materials is available



## Manlid & Inspection Hatch Assemblies Design Options

### Design Options - continued

#### Special Options

Where compatible, we can also offer:

Weld-in fittings: E.g. sockets, flanges, breathers, vents, sight glass

Customer logo: Laser etched on cover

Hand polishing: To ultra-high grade

Lining: For corrosive cargo



### Related Parts

We recommend our range of compatible accessories:

- Manlid cover seals
- Safebolts
- Fasteners

We have a large range of accessories, please contact us for more information about these parts.

### Manlid Assemblies for Dedicated Service

We offer a range of manlid assemblies for these service conditions and special cargoes:

- Elliptical manlid assemblies for brewery & hygienic service
- Flat bolted assemblies for high pressure/dangerous cargo
- U.S. tank trucks
- Rail tank cars
- Hydrogen peroxide service
- Side-entry manlid assemblies for hygienic service

Please contact us for more information about these special assemblies.



# 170mm Inspection Hatch Assembly

Part No: 14I/3100XXA



## Specification

### Nominal size

170mm

### Cover

3 point

### Neckring

Thickness: 6mm

Height range: 75mm to 305mm

### Properties

1x spring-loaded swingbolt assembly lets the cover turn clear of the neckring in the open position

### Materials

Contact parts: 316 stainless steel

Fasteners: stainless steel swingbolts and handnuts

Seal: supplied separately

Alternatives are available, refer to the Design Options page

## Design Conditions

|                         |              |
|-------------------------|--------------|
| Weight:                 | 8.9 Kg *Note |
| Design Pressure (MAWP): | 4 Bar        |
| Test Pressure:          | 6 Bar        |
| Design Temperature Min: | -40°C        |
| Design Temperature Max: | 150°C        |

**NOTE:** The specification changes the weight.  
The Design Temperature limits refer to metal parts only.  
The Design Conditions and Section View dimensions are for the specified part number only.

## Range

| Description         | Part No.     |
|---------------------|--------------|
| With 75mm neckring  | 14I/3100075A |
| With 100mm neckring | 14I/3100100A |
| with 200mm neckring | 14I/3100200A |

## Section View

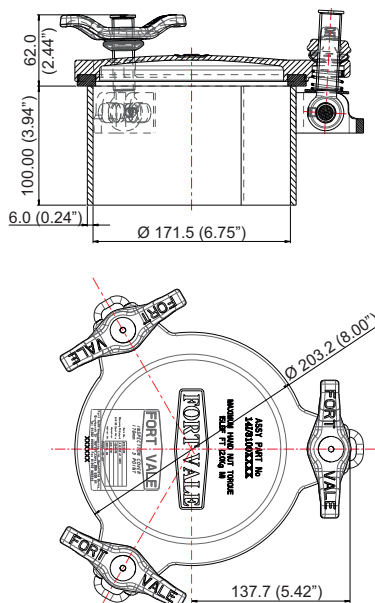



# 170mm Inspection Hatch Assembly

Part No: 14I/3100XXXA

## Parts Drawing

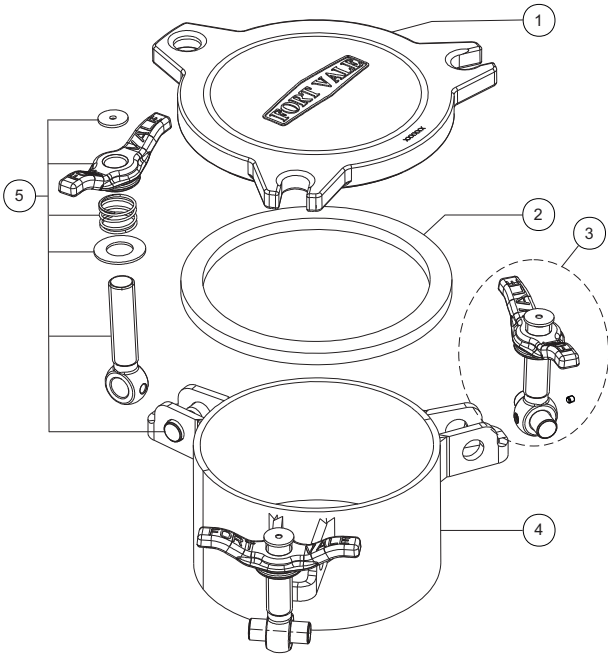

## Parts List

| Item | Description                       | Part No.  |
|------|-----------------------------------|-----------|
| 1    | Cover                             | 672/0120  |
| 2    | Seal (not included) * <b>Note</b> | 5005-XXXX |
| 3    | Swingbolt assembly (2)            | 496/5342  |
| 4    | Neckring * <b>Note</b>            | 661/36XXX |
| 5    | Spring-loaded swingbolt:          |           |
|      | Top washer                        | 5113-080  |
|      | Handnut                           | 490/0310  |
|      | Spring                            | 5104-506  |
|      | Washer                            | 5123-005  |
|      | Swingbolt                         | 540/0342  |
|      | Pivot pin                         | 10913SS   |

**NOTE:** The specification changes the Part No.



# 300mm Inspection Hatch Assembly

Part No: 34C/43XX051E



## Specification

### Nominal size

DN300

### Cover

4 point

### Neckring/compensating ring

Thickness: 8mm

Height: 51mm from TDC

Tank radius profile range: 850mm to 1220mm

### Materials

Contact parts: 316 stainless steel

Fasteners: stainless steel swingbolts with stainless steel handnuts

Seal: supplied separately

Alternatives are available, refer to the Design Options page

## Design Conditions

|                         |         |
|-------------------------|---------|
| Weight:                 | 22.2 Kg |
| Design Pressure (MAWP): | 4 Bar   |
| Test Pressure:          | 6 Bar   |
| Design Temperature Min: | -40°C   |
| Design Temperature Max: | 200°C   |

**NOTE:** The Design Temperature limits refer to metal parts only. The Design Conditions and Section View dimensions are for the specified part number only.

### Design Code

BS EN 14025: 730/0600P cover only

## Range

| Standard Radii | Part No.     |
|----------------|--------------|
| 1040mm         | 34C/4304051E |

## Section View

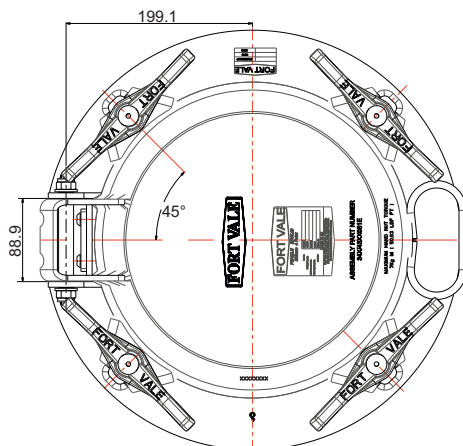
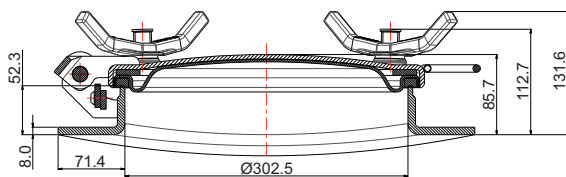



# 300mm Inspection Hatch Assembly

Part No: 34C/43XX051E

## Parts Drawing

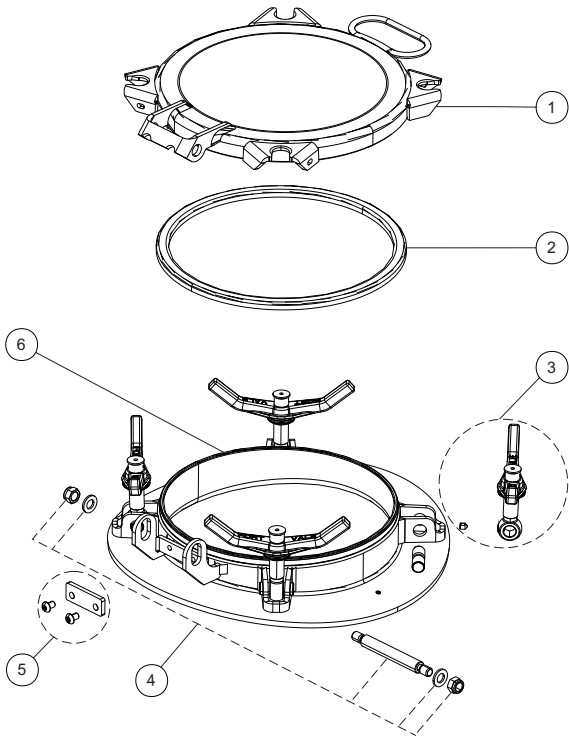

## Parts List

| Item | Description                         | Part No.     |
|------|-------------------------------------|--------------|
| 1    | Cover                               | 703/0600P    |
| 2    | Seal (not included) <b>*Note</b>    | 5005-XXXX    |
| 3    | Swingbolt assembly (4)              | 496/8342     |
| 4    | Hinge pin assembly                  | 600/1060     |
| 5    | Hinge kit                           | 135B         |
| 6    | Neck/compensating ring <b>*Note</b> | 673/2852XXXP |

**NOTE:** The specification changes the Part No.



# 300mm Ultra Low Profile Inspection Hatch Assembly

Part No: 8PB/2750XXXP

## Specification

### Nominal size

DN300

### Cover

4 point

### Neckring/compensating ring

Thickness: 8mm

Tank radius profiling range: 750mm to 1220mm

### Materials

Contact parts: 316 stainless steel

Fasteners: stainless steel swingbolts with naval brass handnuts

Seal: supplied separately

Alternatives are available, refer to the Design Options page



## Design Conditions

|                         |         |
|-------------------------|---------|
| Weight:                 | 19.8 Kg |
| Design Pressure (MAWP): | 4 Bar   |
| Test Pressure:          | 6 Bar   |
| Design Temperature Min: | -40°C   |
| Design Temperature Max: | 200°C   |

**NOTE:** The Design Temperature limits refer to metal parts only. The Design Conditions and Section View dimensions are for the specified part number only.

### Design Code

BS EN 14025: 730/0600P cover only

## Range

| Handnut Material | Part No.     |
|------------------|--------------|
| Naval brass      | 8PB/2750XXXP |
| Stainless steel  | 8PB/2750XXXS |

**NOTE:** The assembly specification changes the Part No.

## Section View

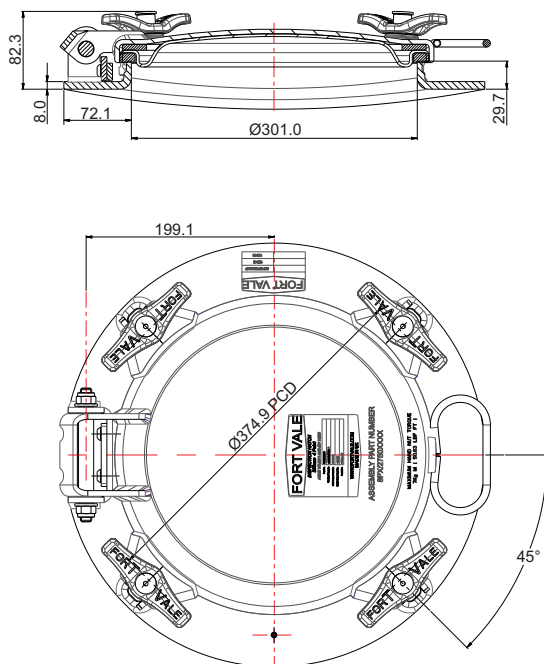





# 300mm Ultra Low Profile Inspection Hatch Assembly

Part No: 8PB/2750XXXP

## Parts Drawing

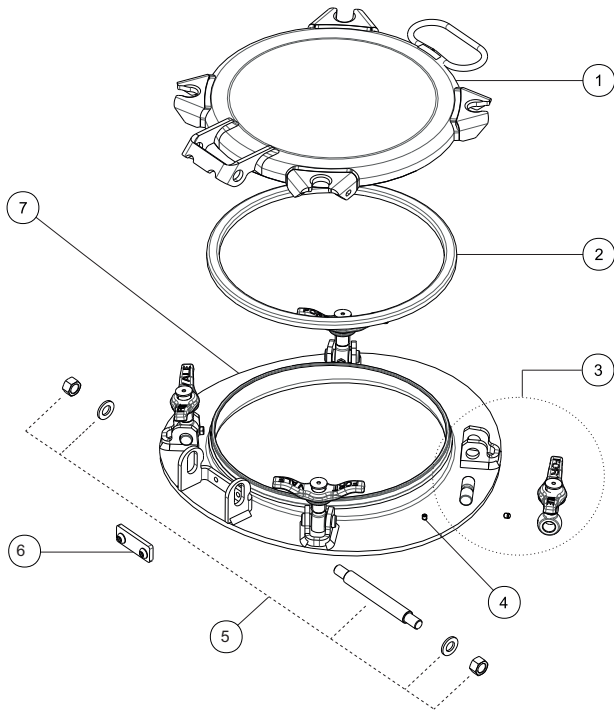

## Parts List

| Item | Description                         | Part No.     |
|------|-------------------------------------|--------------|
| 1    | Cover                               | 703/0600P    |
| 2    | Seal (not included) <b>*Note</b>    | 5005-XXXX    |
| 3    | Swingbolt assembly (4)              | 496/1260     |
| 4    | Grubscrew                           | 5111-009     |
| 5    | Hinge pin assembly                  | 600/1060     |
| 6    | Hinge kit - 135° fixed              | 135B         |
| 7    | Neck/compensating ring <b>*Note</b> | 63P/2750XXXP |

**NOTE:** The specification changes the Part No.





# 460mm Pendle Manlid Assembly

Part No: 44C/6100XXXB



## Specification

### Nominal size

DN450

### Cover

6 point

### Neckring

Thickness: 6mm

Height range: 100mm to 250mm

### Materials

Contact parts: 316 stainless steel

Fasteners: stainless steel swingbolts with naval brass handnuts

Seal: supplied separately

Alternatives are available, refer to the Design Options page

## Design Conditions

|                         |             |
|-------------------------|-------------|
| Weight:                 | 30 Kg *Note |
| Design Pressure (MAWP): | 4 Bar       |
| Test Pressure:          | 6 Bar       |
| Design Temperature Min: | -40°C       |
| Design Temperature Max: | 180°C       |

**NOTE:** The specification changes the weight.  
 The Design Temperature limits refer to metal parts only.  
 The Design Conditions and Section View dimensions are for the specified part number only.

## Section View

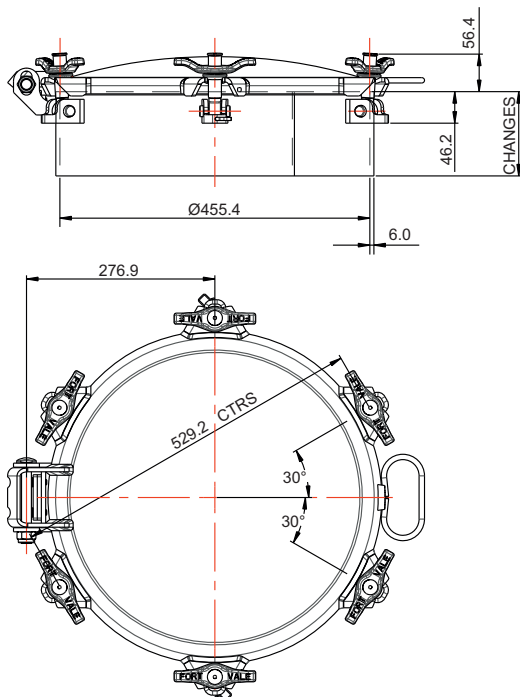



# 460mm Pendle Manlid Assembly

Part No: 44C/6100XXXB

## Parts Drawing

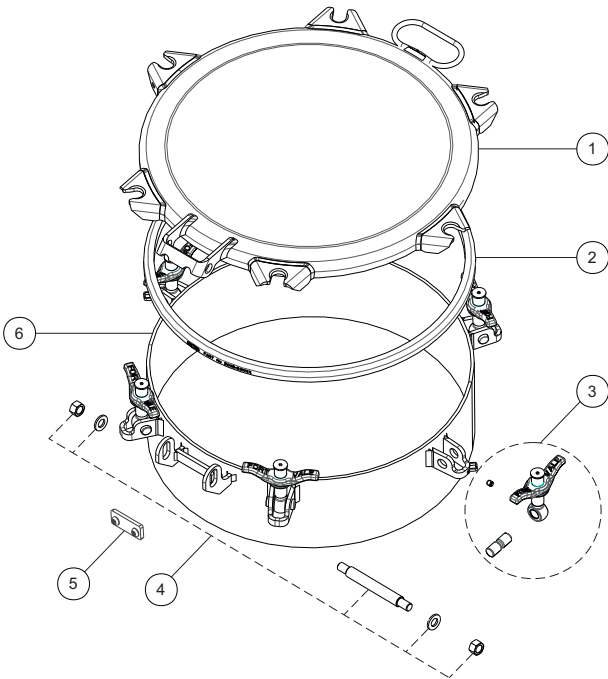

## Parts List

| Item | Description                      | Part No.    |
|------|----------------------------------|-------------|
| 1    | Cover                            | 710/1200P   |
| 2    | Seal (not included) <b>*Note</b> | 5005-XXXX   |
| 3    | Swingbolt assembly (6)           | 496/1342    |
| 4    | Hinge pin assembly               | 600/1060    |
| 5    | Hinge kit                        | 135B        |
| 6    | Neckring <b>*Note</b>            | 664/66XXXXA |

**NOTE:** The specification changes the Part No.



# 500mm Low Pressure Pendle Manlid Assembly

Part No: E1C/4100XXXA



## Specification

### Nominal size

DN500

### Cover

4 point

### Neckring

Thickness: 6mm

Height: 100mm to 300mm

### Materials

Contact parts: 316 stainless steel

Fasteners: stainless steel swingbolts with stainless steel handnuts

Seal: supplied separately

Alternatives are available, refer to the Design Options page

## Design Conditions

|                         |                       |
|-------------------------|-----------------------|
| Weight:                 | 30.5 to 45.7 Kg *Note |
| Design Pressure (MAWP): | 1 Bar                 |
| Test Pressure:          | 1.5 Bar               |
| Design Temperature Min: | -40°C                 |
| Design Temperature Max: | 200°C                 |

**NOTE:** The specification changes the weight.  
The Design Temperature limits refer to metal parts only.  
The Design Conditions and Section View dimensions are for the specified part number only.

## Design Codes

BS EN 14025

## Section View

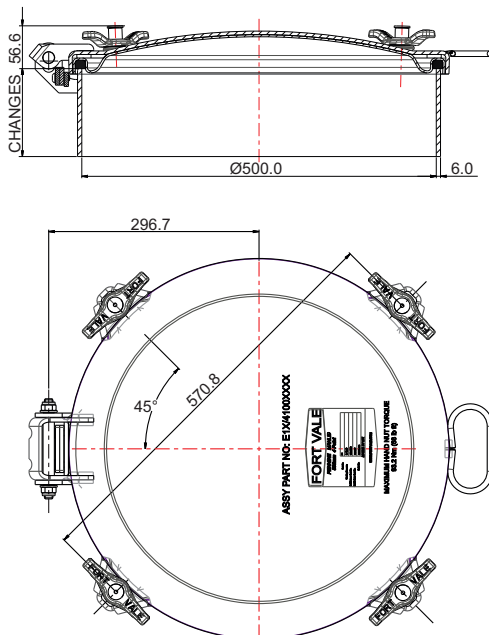



# 500mm Low Pressure Pendle Manlid Assembly

Part No: E1C/4100XXXA

## Parts Drawing

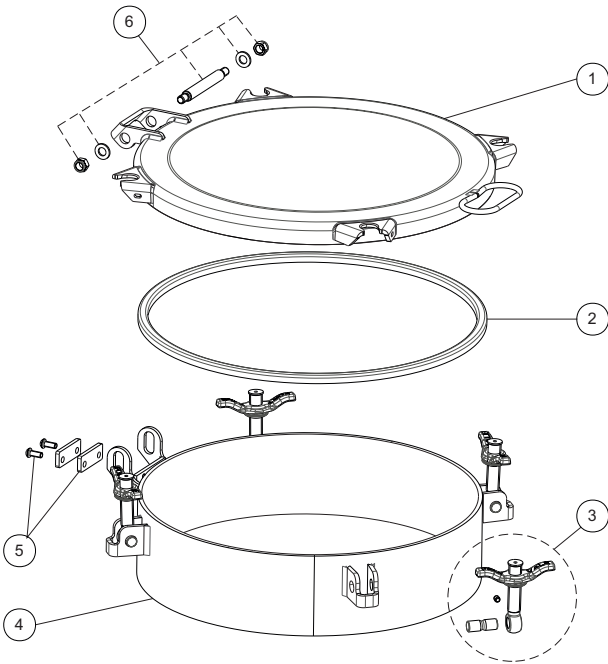

## Parts List

| Item | Description                      | Part No.   |
|------|----------------------------------|------------|
| 1    | Manlid cover                     | 71E/0500   |
| 2    | Seal (not included) <b>*Note</b> | 5005-50XXX |
| 3    | Swingbolt assembly (6)           | 496/5379   |
| 4    | Neckring <b>*Note</b>            | 66E/46XXXA |
| 5    | Hinge kit                        | 135B       |
| 6    | Hinge pin assembly               | 600/1060   |

**NOTE:** The specification changes the Part No.



# 500mm Pendle Manlid Assembly

Part No: E3C/6100XXXB



## Specification

### Nominal size

DN500

### Cover

6 point

### Neckring

Thickness: 6mm

Height: 60mm to 350mm

### Materials

Contact parts: 316 stainless steel

Fasteners: stainless steel swingbolts with naval brass handnuts

Seal: supplied separately

Alternatives are available, refer to the Design Options page

## Design Conditions

|                         |                       |
|-------------------------|-----------------------|
| Weight:                 | 28.6 to 50.9 Kg *Note |
| Design Pressure (MAWP): | 3 Bar                 |
| Test Pressure:          | 4.5 Bar               |
| Design Temperature Min: | -40°C                 |
| Design Temperature Max: | 250°C                 |

**NOTE:** The specification changes the weight.  
 The Design Temperature limits refer to metal parts only.  
 The Design Conditions and Section View dimensions are for the specified part number only.

## Design Codes

BS EN 14025

## Section View

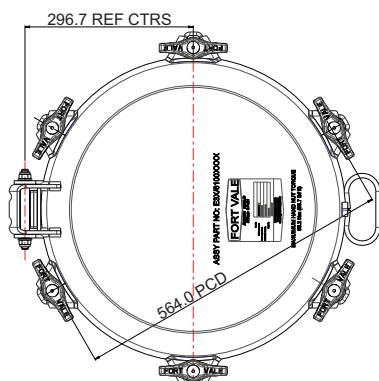
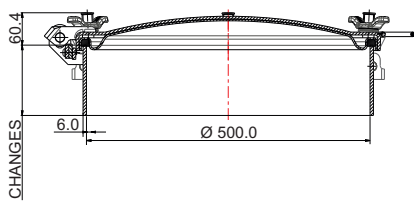



# 500mm Pendle Manlid Assembly

Part No: E3C/6100XXXB

## Parts Drawing

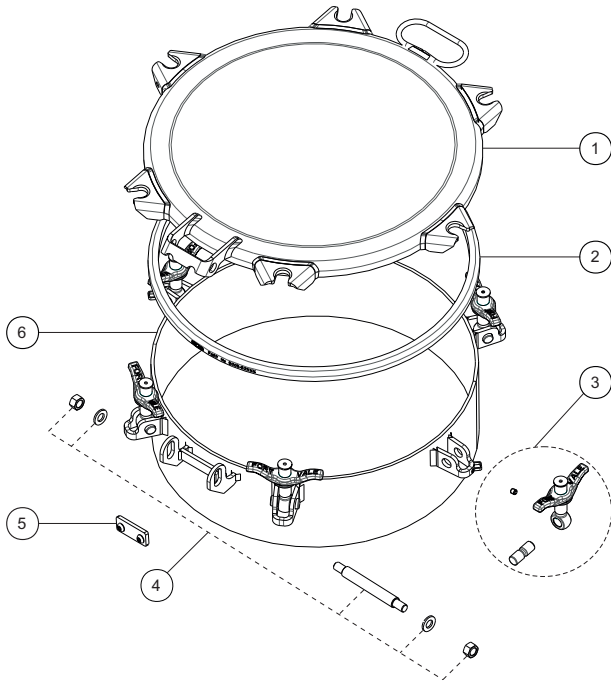

## Parts List

| Item | Description                      | Part No.   |
|------|----------------------------------|------------|
| 1    | Manlid cover                     | 73E/0500   |
| 2    | Seal (not included) <b>*Note</b> | 5005-50XXX |
| 3    | Swingbolt assembly (6)           | 496/1375   |
| 4    | Hinge pin assembly               | 600/1060   |
| 5    | Hinge kit                        | 135B       |
| 6    | Neckring <b>*Note</b>            | 66E/66XXXA |

**NOTE:** The specification changes the Part No.



# 500mm Ultra Low Profile Pendle Manlid Assembly

Part No: E4C/85XX025B



## Specification

### Nominal size

DN500

### Cover

8 point

### Neckring/compensating ring

Thickness: 8mm

Tank radius profiling range: 750mm to 1300mm

### Materials

Contact parts: 316 stainless steel

Fasteners: stainless steel swingbolts with naval brass handnuts

Seal: supplied separately

Alternatives are available, refer to the Design Options page

## Design Conditions

|                         |       |
|-------------------------|-------|
| Weight:                 | 40 Kg |
| Design Pressure (MAWP): | 4 Bar |
| Test Pressure:          | 6 Bar |
| Design Temperature Min: | -40°C |
| Design Temperature Max: | 200°C |

**NOTE:** The Design Temperature limits refer to metal parts only. The Design Conditions and Section View dimensions are for the specified part number only.

### Design Codes

BS EN14025: 74E/0500 cover only (4 Bar)

BS EN14025: 73E/0500 cover only (3 Bar)

## Range

| Points | MAWP  | Part No.     |
|--------|-------|--------------|
| 8      | 4 Bar | E4C/85XX025B |
| 6      | 3 Bar | E3C/65XX025B |

**NOTE:** The assembly specification changes the Part No.

## Section View

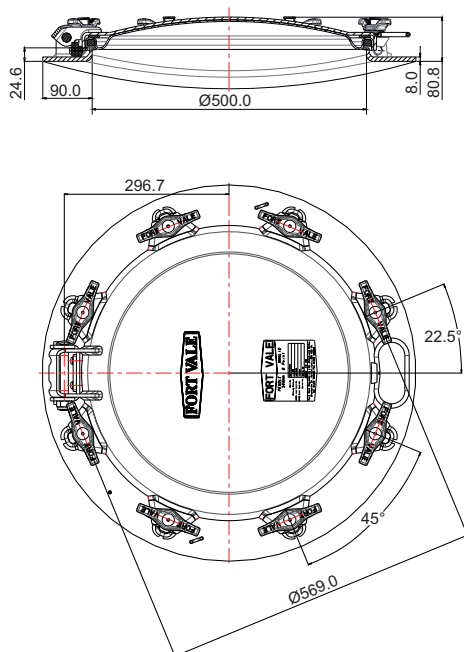



# 500mm Ultra Low Profile Pendle Manlid Assembly

Part No: E4C/85XX025B

## Parts Drawing

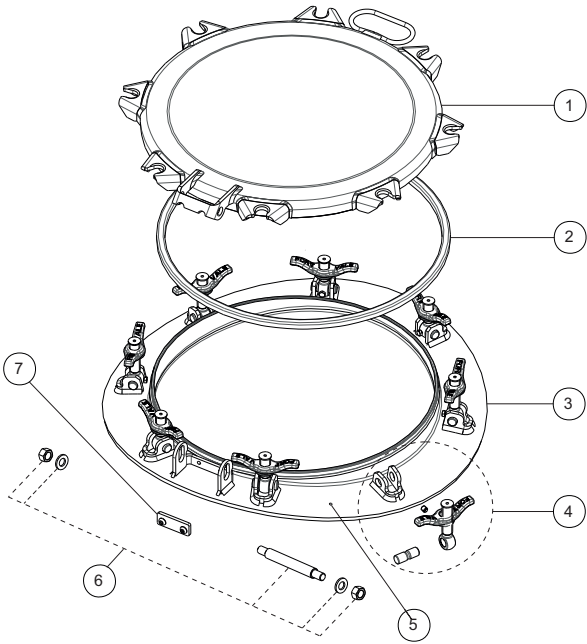

## Parts List

| Item | Description                    | Part No.     |
|------|--------------------------------|--------------|
| 1    | Cover                          | 74E/0500     |
| 2    | Seal (not included) *Note      | 5005-XXXX    |
| 3    | Neck/compensating ring *Note   | 6EP/7403XXXP |
| 4    | Long swingbolt assy. (4) *Note | 496/XXXX     |
|      | Short swingbolt assembly (4)   | 496/1240     |
| 5    | Grub screw                     | 5111-009     |
| 6    | Hinge pin assembly             | 600/1060     |
| 7    | Hinge kit - 135° fixed         | 135B         |

**NOTE:** The specification changes the Part No.





# 500mm Ultra Low Profile Manlid Assembly: H<sub>2</sub>O<sub>2</sub>

Part No: E4X-85XX013A

## Specification

### Nominal size

DN500

### Cover

8 point with a fill pipe flange assembly & a breather vent assembly with sintered disc and low-leak cap with secondary sintered disc

### Neckring/compensating ring

Thickness: 8mm

Tank radius profiling range: 950mm to 1260mm

### Materials

Contact parts: 316 stainless steel

Fasteners: stainless steel swingbolts and handnuts

Fill pipe gasket & breather vent seals: PTFE

Manlid cover seal: supplied separately

Alternatives are available, refer to Fort Vale



## Design Conditions

|                         |         |
|-------------------------|---------|
| Weight:                 | 57.8 Kg |
| Design Pressure (MAWP): | 4 Bar   |
| Test Pressure:          | 6 Bar   |
| Design Temperature Min: | -40°C   |
| Design Temperature Max: | 200°C   |

**NOTE:** The Design Temperature limits refer to metal parts only. The Design Conditions and Section View dimensions are for the specified part number only.

### Design Codes

BS EN 14025

## Section View

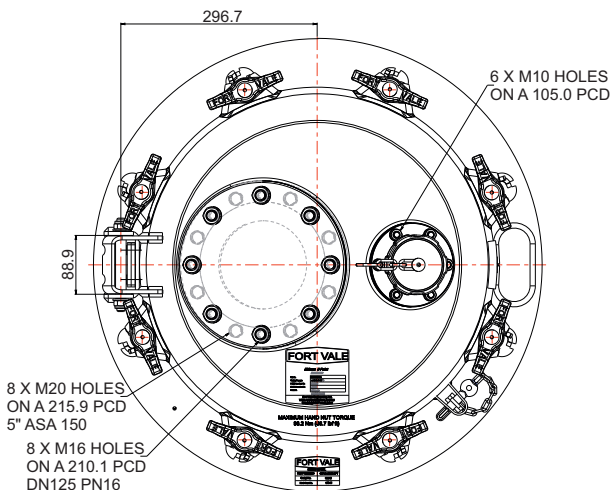
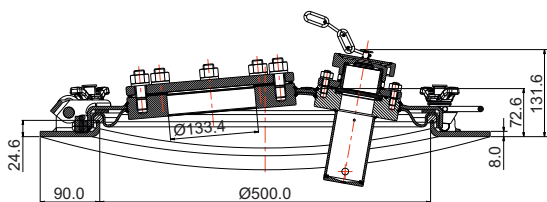



# 500mm Ultra Low Profile Manlid Assembly: H<sub>2</sub>O<sub>2</sub>

Part No: E4X-85XX013A

## Parts Drawing

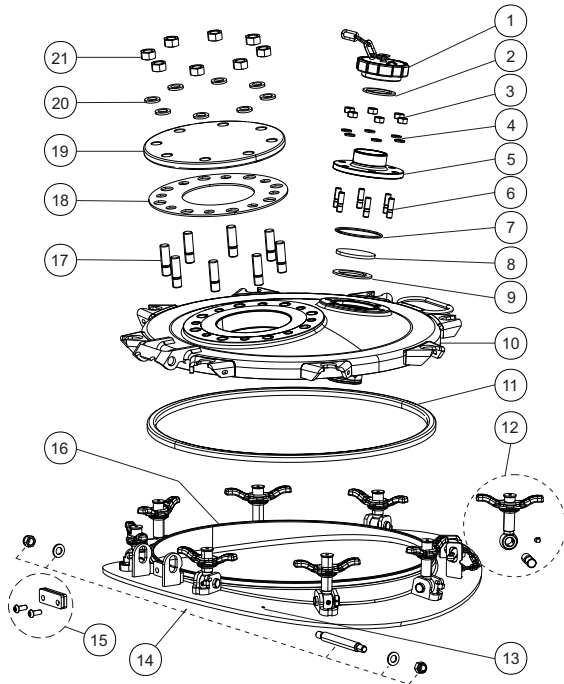

## Parts List

| Item | Description                    | Part No.      |
|------|--------------------------------|---------------|
| 1    | Breather cap assembly          | 674/3040      |
| 2    | Breather cap seal              | 5005-414      |
| 3    | M10 full nut (6)               | 5112-002      |
| 4    | M10 spring washer (6)          | 5113-002      |
| 5    | 2" BSP outlet                  | 674/3546      |
| 6    | M10 x 35mm stud (6)            | 371/0001      |
| 7    | PTFE O ring                    | 5005-235      |
| 8    | Sintered disc                  | 865/2000      |
| 9    | PTFE gasket                    | 5005-435      |
| 10   | Manlid cover                   | 74E/0550T     |
| 11   | Seal (not included) *Note      | 5005-XXXX     |
| 12   | Short swingbolt assy. (4)      | 496/5250      |
|      | Long swingbolt assy. (4) *Note | 496/5XXX      |
| 13   | M6 set screw                   | 5111-009      |
| 14   | Hinge pin assembly             | 600/1060      |
| 15   | Hinge kit *Note                | 135B          |
| 16   | Neckring *Note                 | 6EP/7403XXXPT |
| 17   | M16 x 60mm stud (8)            | 368/1109      |
| 18   | PTFE fill flange gasket        | 5005-411      |
| 19   | Blind flange                   | 674/5051      |
| 20   | M16 spring washer (8)          | 5113-012      |
| 21   | M16 full nut (8)               | 5112-003      |

**NOTE:** The specification changes the Part No.



# 500mm Manlid Assembly with Quick Release Latches

Part No: 8EZ/66XXXSH



## Specification

### Nominal size

DN500

### Cover

6 point

### Neckring

Thickness: 6mm

Height range: 100mm to 180mm

### Materials

Contact parts: 316 stainless steel

Fasteners: Nitronic 60 swingbolts with stainless steel quick release latches

Seal: supplied separately

Alternatives are available, refer to Range

## Design Conditions

|                         |                       |
|-------------------------|-----------------------|
| Weight range:           | 34.4 to 40.5 Kg *Note |
| Design Pressure (MAWP): | 2.5 Bar               |
| Test Pressure:          | 3.25 Bar              |
| Design Temperature Min: | -20°C                 |
| Design Temperature Max: | 150°C                 |

**NOTE:** The specification changes the weight.  
The Design Temperature limits refer to metal parts only.  
The Design Conditions and Section View dimensions are for the specified part number only.

### Design Codes

BS EN 14025

## Range

| Description               | Part No.    |
|---------------------------|-------------|
| Standard assembly         | 8EZ/66XXXSH |
| With RJT fitting in cover | 8EZ/67XXXSH |
| With insulated cover      | 8EZ/68XXXSH |

**NOTE:** The neckring height changes the Part No.

## Section View

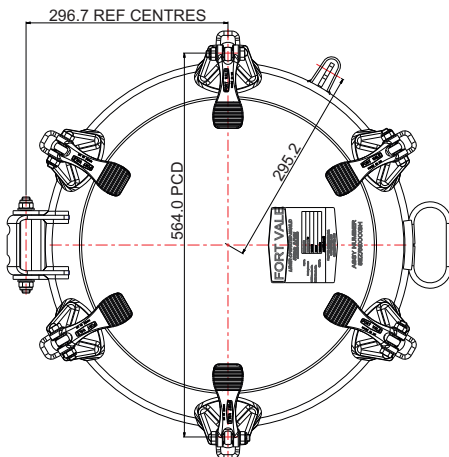
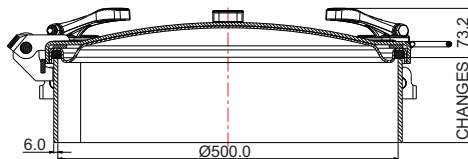



# 500mm Manlid Assembly with Quick Release Latches

Part No: 8EZ/66XXXSH

## Parts Drawing

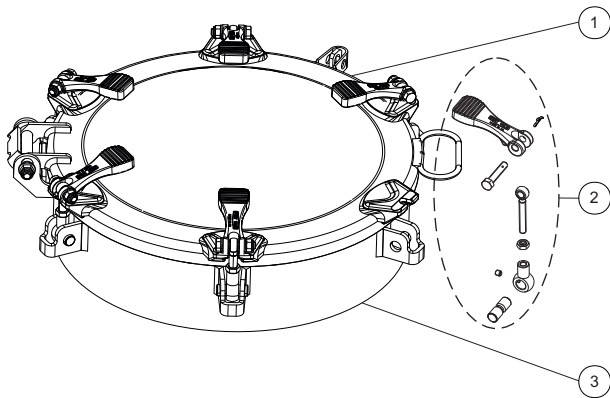

## Parts List

| Item | Description                                    | Part No.    |
|------|--|-------------|
| 1    | Manlid cover                                   | 73E/7200    |
| 2    | Quick release swingbolt assembly (6) see below | 86Z/0001    |
| 3    | Neckring *Note                                 | 66E/66XXXSH |

**NOTE:** The specification changes the Part No.

## Swingbolt Assembly Parts Drawing

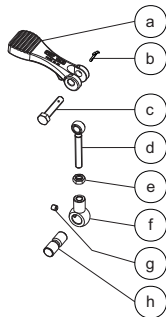

## Swingbolt Assembly Parts List

| Item | Description               | Part No.    |
|------|---------------------------|-------------|
| a    | Quick release handle      | 490/4000    |
| b    | Split pin                 | 5118-016    |
| c    | Clevis pin                | 895/1645/8N |
| d    | M12 swingbolt             | 86Z/0003    |
| e    | M12 half nut              | 5112-017    |
| f    | 16mm eye female swingbolt | 86Z/0002    |
| g    | M8 socket screw           | 5111-002    |
| h    | 16mm swingbolt pin        | 10913SS     |



# 600mm Manlid Assembly

Part No: 63C/6100XXXB



## Specification

### Nominal size

DN600

### Cover

6 point

### Neckring

Thickness: 6mm

Height range: 100mm to 500mm

### Materials

Contact parts: 316 stainless steel

Fasteners: stainless steel swingbolts with naval brass handnuts

Seal: supplied separately

Alternatives are available, refer to the Design Options page

## Design Conditions

|                         |             |
|-------------------------|-------------|
| Weight:                 | 44 Kg *Note |
| Design Pressure (MAWP): | 3 Bar       |
| Test Pressure:          | 4.5 Bar     |
| Design Temperature Min: | -29°C       |
| Design Temperature Max: | 200°C       |

**NOTE:** The specification changes the weight.  
The Design Temperature limits refer to metal parts only.  
The Design Conditions and Section View dimensions are for the specified part number only.

## Section View

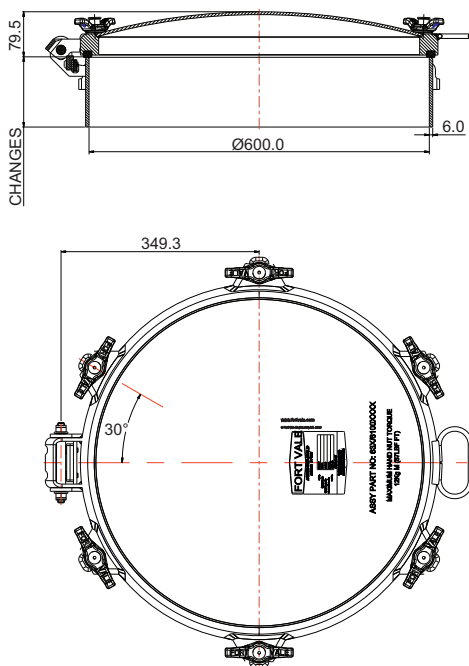



# 600mm Manlid Assembly

Part No: 63C/6100XXXB

## Parts Drawing

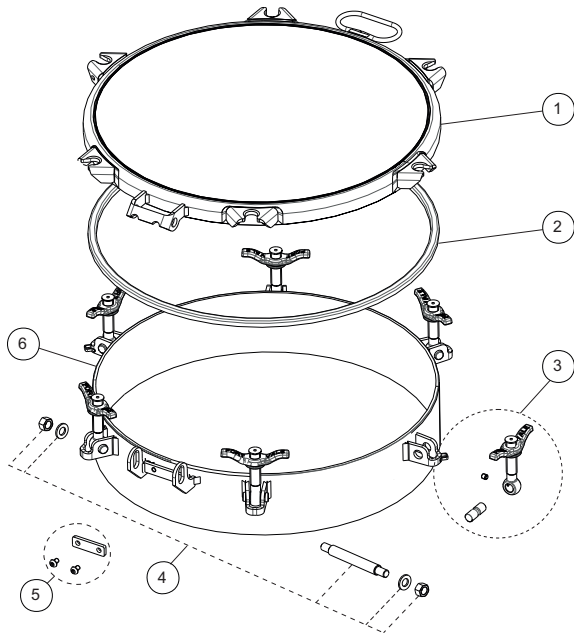

## Parts List

| Item | Description                       | Part No.    |
|------|-----------------------------------|-------------|
| 1    | Cover                             | 606/2500P   |
| 2    | Seal (not included) * <b>Note</b> | 5005-XXXX   |
| 3    | Swingbolt assembly (6)            | 496/1400    |
| 4    | Hinge pin assembly                | 600/1060    |
| 5    | Hinge kit                         | 135B        |
| 6    | Neckring * <b>Note</b>            | 666/66XXXXA |

**NOTE:** The specification changes the Part No.



# Elliptical Manlid Assembly - Low Profile Neckring

Part No: 850/7500VXX



## Specification

### Nominal size

508mm x 406mm

### Neckring

Thickness: 10mm

Height: 73.2mm

### Properties

Cross-arm with handnut to clamp and seal the assembly;  
2x handles to move the cover to the open/closed position

### Operation

The cover opens into the vessel and turns to move out of the neckring, clear of the vessel

### Materials

Contact parts: 316 stainless steel, cover surface finish  
0.8um - 0.5um

Seal: vulcanised - refer to Range

## Design Conditions

|                         |                       |
|-------------------------|-----------------------|
| Weight:                 | 25.3 Kg               |
| Design Pressure (MAWP): | 3 Bar                 |
| Design Vacuum:          | -0.20 Bar *Conditions |
| Design Temperature Min: | -40°C (metal parts)   |
| Design Temperature Max: | 150°C (metal parts)   |

**Vacuum Conditions:** The assembly is compatible with -0.20 Bar vacuum only if neckring distortion caused by welding is kept to a minimum.

**NOTE:** The working temperature of the seal can change the design temperature limits. The Design Conditions and Section View dimensions are for the specified part number only.

## Range

| Description                             | Part No.    |
|---|-------------|
| With vulcanised black EPDM seal         | 850/7500VEP |
| With vulcanised blue nitrile seal       | 850/7500VBN |
| With vulcanised sweet white rubber seal | 850/7500VSW |

## Section View

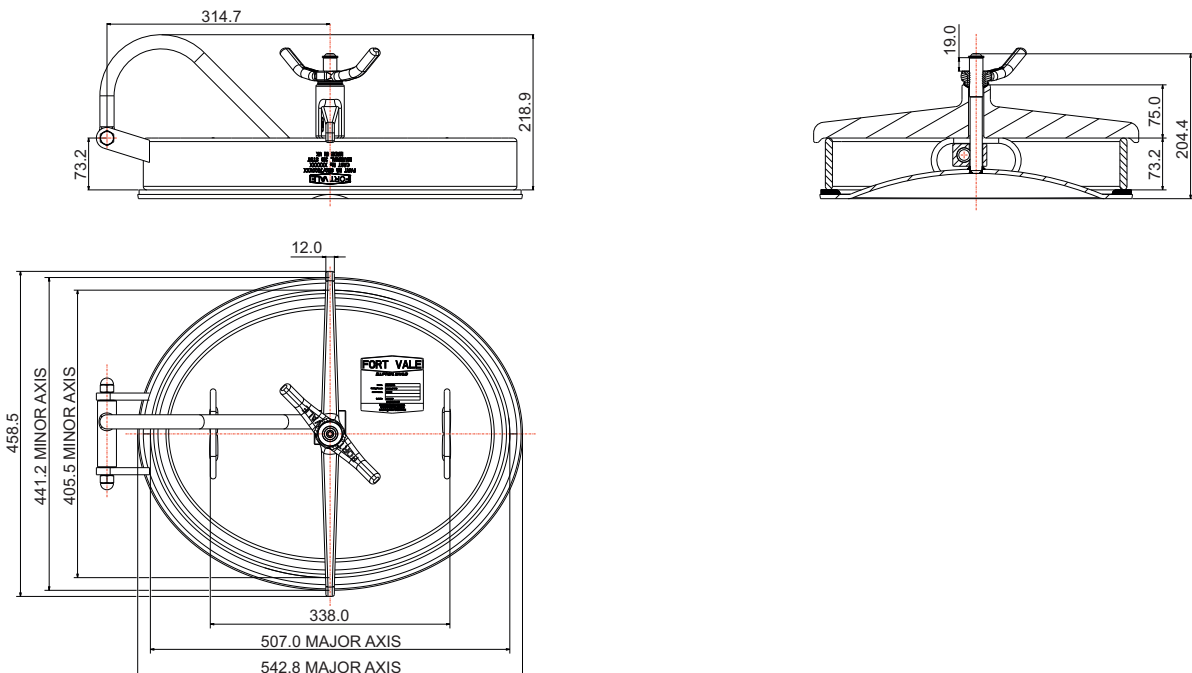





# Elliptical Manlid Assembly - Deep Neckring

Part No: 850/7600VXX



## Specification

### Nominal size

508mm x 406mm

### Neckring

Thickness: 10mm

Height: 200.7mm

### Properties

Cross-arm with handnut to clamp and seal the assembly;  
2x handles to move the cover to the open/closed position

### Operation

The cover opens into the vessel and turns to move out of the neckring, clear of the vessel

### Materials

Contact parts: 316 stainless steel, cover surface finish  
0.8um - 0.5um

Seal: vulcanised - refer to Range

## Design Conditions

|                         |                       |
|-------------------------|-----------------------|
| Weight:                 | 41.3 Kg               |
| Design Pressure (MAWP): | 3 Bar                 |
| Design Vacuum:          | -0.20 Bar *Conditions |
| Design Temperature Min: | -40°C (metal parts)   |
| Design Temperature Max: | 150°C (metal parts)   |

**Vacuum Conditions:** The assembly is compatible with -0.20 Bar vacuum only if neckring distortion caused by welding is kept to a minimum.

**NOTE:** The working temperature of the seal can change the design temperature limits. The Design Conditions and Section View dimensions are for the specified part number only.

## Range

| Description                       | Part No.    |
|-----------------------------------|-------------|
| With vulcanised black EPDM seal   | 850/7600VEP |
| With vulcanised blue nitrile seal | 850/7600VBN |

## Section View

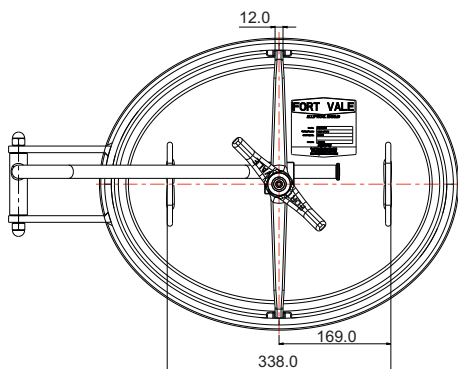
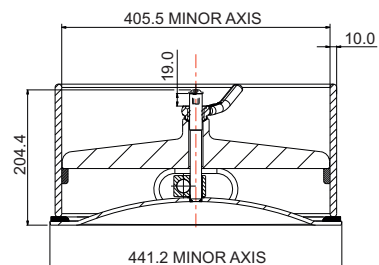
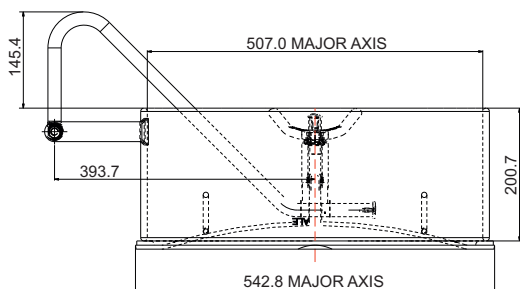





# Elliptical Manlid Assembly - Deep Neckring

Part No: 850/7600VXX

## Parts Drawing

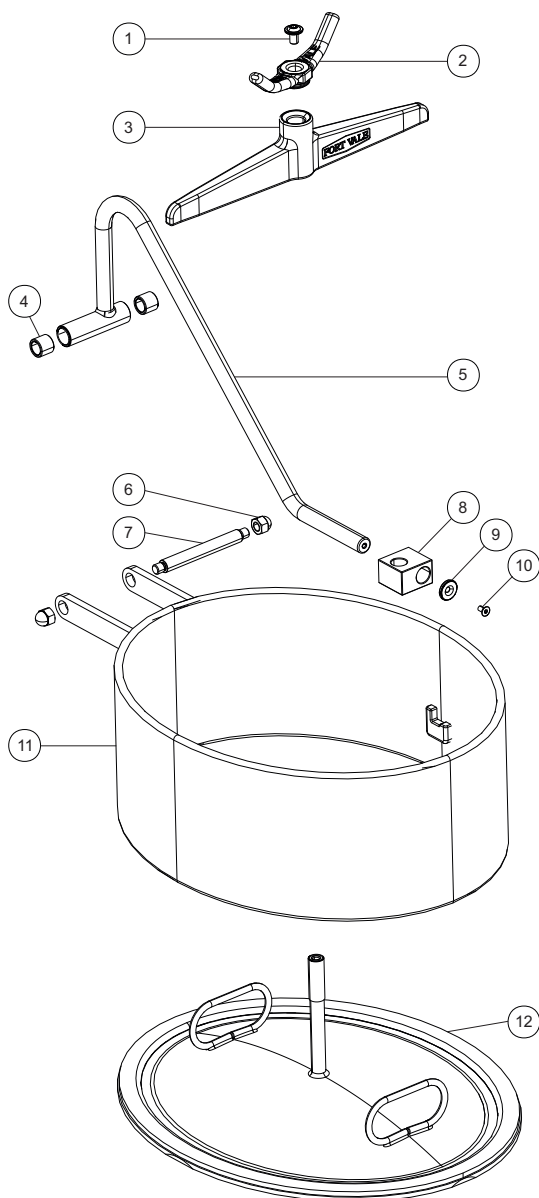

## Parts List

| Item | Description                             | Part No.     |
|------|---|--------------|
| 1    | M10 flanged button screw                | 5111-600     |
| 2    | 3/4" star lock handnut                  | 490/0410     |
| 3    | Cross arm                               | 750/6535DC   |
| 4    | Gunmetal bush (2)                       | 650/6001     |
| 5    | Pivot beam assembly                     | 650/6535     |
| 6    | M12 dome nut (2)                        | 5112-050     |
| 7    | Hinge pin                               | 650/6008     |
| 8    | Long pivot block                        | 750/2501     |
| 9    | Retaining washer                        | 20370/2      |
| 10   | 6mm countersunk bolt                    | 5111-018     |
| 11   | Neckring                                | 650/6530     |
| 12   | Cover with vulcanised seal <b>*Note</b> | 750/6070VSXX |

**NOTE:** The specification changes the Part No.



## Safebolt Assembly

Part No: 496/4XXX

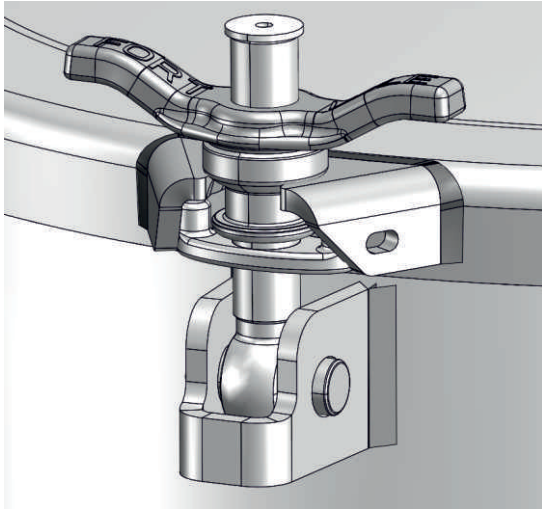

### Specification

#### Description

Safebolt assembly including eyebolt with pivot pin, retaining collar and captivated low profile safebolt handnut

#### Size

Eyebolt:  $\frac{3}{4}$ " BSW eyebolt with  $\varnothing$  16mm eye, available length from 66mm to 175.3mm (Dimension C)  
Safebolt handnut & retaining collar:  $\frac{3}{4}$ " BSW  
Pivot pin:  $\varnothing$  16mm

#### Materials

304 stainless steel

#### Options

Eyebolt:  $\frac{3}{4}$ " eye - refer to Fort Vale  
Handnut: refer to the Range table

#### Special instructions

The customer must set the retaining collar and weld it in the correct position. Refer to the procedure below.

### Section View: 496/4XXX

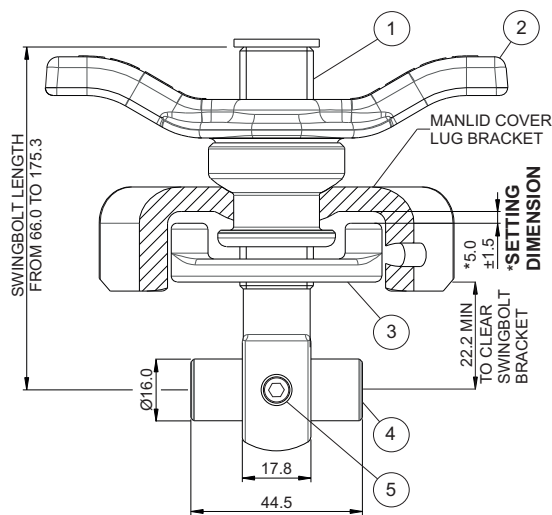

### Range: Standard Safebolt Assemblies

| Handnut Description   | Part No.   |
|---|------------|
| Low profile stainless steel *Note   | 496/4XXX   |
| Low profile anti-galling - stainless steel with brass thread insert *Note | 496/EXXXSB |
| Extended anti-galling - stainless steel with brass thread insert *Note    | 496/CXXXSB |

### Parts List: 496/4XXX

| Item | Description                                 | Part No. |
|------|---|----------|
| 1    | $\frac{3}{4}$ " BSW eyebolt, 16mm eye *Note | 540/0XXX |
| 2    | Low profile st.st. safebolt handnut         | 490/0305 |
| 3    | Retaining collar                            | 701/0050 |
| 4    | $\varnothing$ 16mm pivot pin                | 10913SS  |
| 5    | M8 grubscrew                                | 5111-002 |

**NOTE:** The eyebolt length changes the Part No.

### IMPORTANT PRECAUTIONS

A safebolt must be installed opposite the manlid hinge. The safebolt retaining collar must be set by the customer. This includes a safebolt that is supplied as part of a manlid assembly and a safebolt supplied as a spare part.

#### How to set the safebolt retaining collar:

- With the safebolt assembly installed in the neckring lug bracket, start with the retaining collar at the bottom of the swingbolt thread. Engage the safebolt assembly with the manlid cover lug bracket.
- Do not tighten the handnut, there must be no compression on the seal.
- Measure the SETTING DIMENSION (Refer to the Section View).
- Disengage the safebolt assembly from the cover lug and move the retaining collar up to the correct position.
- Engage the safebolt assembly with the cover lug bracket again. Check that the SETTING DIMENSION is satisfactory. Adjust the position of the retaining collar if necessary.
- When the SETTING DIMENSION is satisfactory, tack weld the retaining collar to the eyebolt.
- The safebolt retaining collar is now set.

**CAUTION:** If you change the seal material type in your manlid cover, you must check the setting dimension again. It is possible that you must change the position of the retaining collar to be compatible with the new seal.

Please read the User Manual on page 2.



# Safebolt Assembly - User Manual

Part No: 496/4XXX

## Overview

A safebolt is a special fastener that can be used on all standard manlid assemblies. It is a safety device that permits the controlled release of residual tank pressure before the manlid is opened.

If there is residual tank pressure, the manlid cover can open suddenly with force which can cause serious injury to the operator. A safebolt lets the operator break the seal between the manlid cover and the neckring while it holds the manlid cover in a retained position, thus preventing the risk of injury.

## Precautions

Install the safebolt next to the manlid cover handle, opposite the hinge. Obey the SETTING DIMENSION - refer to the Section View on page 1.

When you operate a manlid assembly installed with a safebolt you must:

- release the safebolt last when you open the manlid.
- fasten the safebolt first when you close the manlid.

**WARNING:** Before you try to open the manlid, make sure that the vessel/system pressure is at zero. When all the vessel/system pressure is released, use an approved method to release all residual pressure before you loosen any fasteners. If you do not release all pressure, the manlid cover can open suddenly with force which can cause serious injury or death. Open the fasteners gradually in a diametrically opposite sequence.

## Operation

This information is for general guidance only. For more information, please refer to our Installation & Operating Instructions - Hinged Manlid Assemblies.

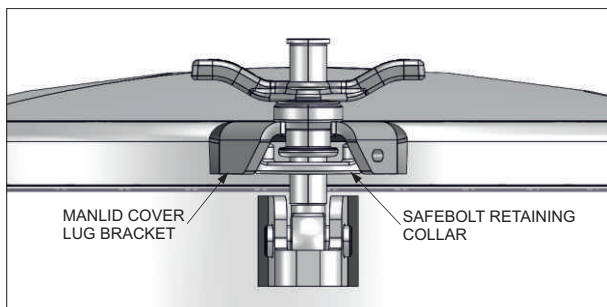

Figure 1 - Closed Position

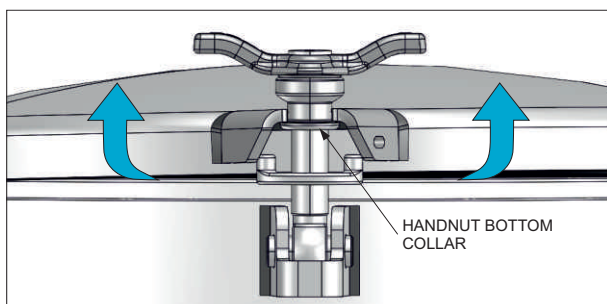

Figure 2 - Retained Position

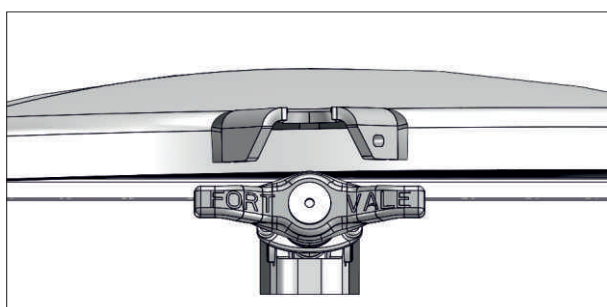

Figure 3 - Open Position

## Closed Position

When the safebolt is in the closed position, the safebolt keeps the manlid cover closed. Refer to Figure 1.

If the handnut becomes loose accidentally, the safebolt retaining collar keeps the eyebolt in the vertical position. This prevents the manlid cover from opening suddenly if there was an increase of pressure in the vessel.

## Retained Position

To operate the safebolt, loosen the handnut and keep the safebolt in the vertical position. When the handnut is loosened, the handnut bottom collar lifts the manlid cover up. This breaks the seal between the manlid seal and the neckring but keeps the manlid cover in a safe "retained position" to prevent it from opening suddenly. Refer to Figure 2.

Make sure that all residual pressure is released before you move the safebolt to the open position.

## Open Position

To put the safebolt in the open position, turn the handnut until it touches the top retaining washer on the eyebolt. This gives clearance between the safebolt retaining collar and the manlid cover lug bracket. You can then rotate the safebolt assembly away from the manlid cover. Refer to Figure 3.

If the safebolt is difficult to rotate away, use the manlid cover handle to lift the manlid cover by a small amount.



## Swingbolt Assemblies

### Accessories & Spare Parts



We supply a range of swingbolt assemblies with different eyebolt lengths and handnut types.

The standard sizes shown are the most frequently used. If the size you want is not shown, please contact us.

A complete swingbolt assembly includes the eyebolt, the pivot pin (attached with a grub screw) and the handnut with captivating washer. You can also buy all these components separately.

For Safebolt assemblies, please refer to data sheet SPA065 or contact us for more information.

### Standard Swingbolt Assemblies

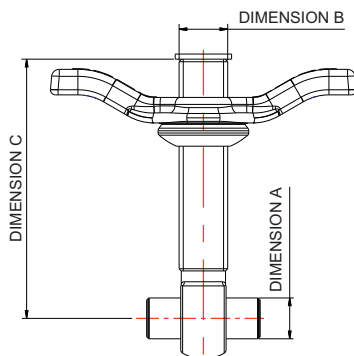

### Specification

#### Eyebolt options

Ø eye: Dimension A - 16mm or 3/4"

Thread: Dimension B - 3/4" BSW

Length: Dimension C - from 49.3mm to 175.3mm

NOTE: Length is measured from the centre of the eye to the end of the bolt

Material: stainless steel

#### Standard handnut options

Low profile stainless steel

Low profile naval brass with stainless steel thrust washer

Extended stainless steel with anti-galling brass thread

#### Special handnut options

Extended stainless steel

Low profile stainless steel with anti-galling brass thread

Hexagonal stainless steel nut

### Range: Standard Swingbolt Assemblies

The sizes shown are the most frequently used. If the size you want is not shown, please contact us.

#### 16mm Eye Swingbolt Assemblies

| Eyebolt Length<br>(Dimension C) | Handnut         |             |                       |          |
|---------------------------------|-----------------|-------------|-----------------------|----------|
|                                 | Stainless Steel | Naval Brass | Anti-galling Extended |          |
| mm                              | inches          | Handnut     | Handnut               |          |
| 62                              | 2.44            | 496/5260    | 496/1260              | -        |
| 66                              | 2.60            | 496/5275    | 496/1275              | 496/C260 |
| 70                              | 2.75            | 496/5290    | 496/1290              | 496/C275 |
| 83                              | 3.26            | 496/5342    | 496/1342              | -        |
| 87                              | 3.42            | 496/5358    | 496/1358              | 496/C342 |
| 92                              | 3.63            | 496/5379    | 496/1379              | 496/C379 |
| 95                              | 3.75            | 496/5375    | 496/1375              | 496/C375 |
| 108                             | 4.25            | 496/5425    | 496/1425              | 496/C425 |
| 133.4                           | 5.25            | 496/5525    | 496/1525              | 496/C525 |

#### 3/4" Eye Swingbolt Assemblies

| Eyebolt Length<br>(Dimension C) | Handnut         |             |          |
|---------------------------------|-----------------|-------------|----------|
|                                 | Stainless Steel | Naval Brass |          |
| mm                              | inches          | Handnut     |          |
| 66                              | 2.60            | 495/1005    | 495/1081 |
| 87                              | 3.42            | 495/1015    | 495/1060 |
| 95                              | 3.75            | 495/1059    | 495/1055 |
| 120.7                           | 4.75            | 495/0210    | -        |

### Related Parts

| Description  | Part No. |
|--|----------|
| Handnut torque increase tool, compatible with low profile handnuts | 495/10T0 |



## Swingbolt Assembly Components

### Accessories & Spare Parts

#### 16mm Eye (A) x 3/4" BSW Eyebolt (B)

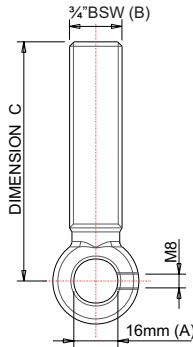

#### Specification

Supplied as standard with an M8 grub screw  
 Length options (C): from 49.3mm to 175.3mm  
 Material: stainless steel  
 Other eye sizes and thread types are available, please contact us.

| Eyebolt Length (Dimension C) |        | Part No. |
|------------------------------|--------|----------|
| mm                           | inches |          |
| 69.85                        | 2.75   | 540/0275 |
| 75.95                        | 2.99   | 540/0299 |
| 80.01                        | 3.15   | 540/0315 |
| 95.25                        | 3.75   | 540/0375 |

#### 3/4" BSW Handnut

##### Standard low profile handnut

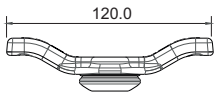

##### Anti-galling handnut

###### Low profile

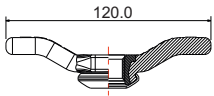

###### Extended

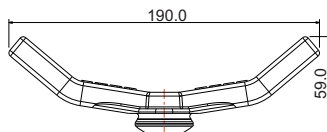

##### Hexagonal nut

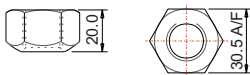

#### Specification

Standard handnuts are low profile in stainless steel or naval brass.

Special handnuts include extended stainless steel and anti-galling in stainless steel with a brass thread insert. These are available low profile or extended.

For our flat bolted manlids, we also supply stainless steel hexagonal nuts.

| Description              | Material                                       | Part No. |
|--------------------------|--|----------|
| Low profile              | Stainless steel                                | 490/0310 |
| Low profile              | Naval brass with stainless steel thrust washer | 490/1060 |
| Extended                 | Stainless steel                                | 490/0313 |
| Anti-galling low profile | Stainless steel with brass thread insert       | 490/0380 |
| Anti-galling extended    | Stainless steel with brass thread insert       | 490/0410 |
| Hexagonal nut            | Stainless steel                                | 490/1190 |

#### Eyebolt Pivot Pin



#### Specification

Standard Ø: 16mm or 3/4"  
 Material: stainless steel

| Description          | Part No. |
|----------------------|----------|
| Ø 16mm x 44.5mm long | 10913SS  |
| Ø 3/4" x 1.82" long  | 10911SS  |

#### Related Parts

##### Manlid/Neckring Hinge Pin Assembly



#### Specification

Includes the pin, washers and nyloc nuts  
 Material: stainless steel

| Description                        | Part No. |
|------------------------------------|----------|
| Manlid/neckring hinge pin assembly | 600/1060 |



# Swingbolt Assembly Part Number Code

## Accessories & Spare Parts

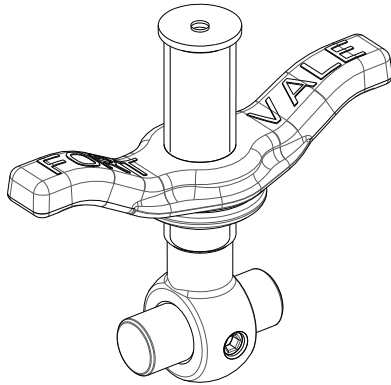

Example: **4 9 6 / X X X X**

|  |  |  |  |  |  |
|--|--|--|--|--|--|
|  |  |  |  |  |  |
|--|--|--|--|--|--|

### 496/ Specification

16mm eye x 3/4"BSW swingbolt assembly, including eyebolt, hinge pin and captivated handnut.

### 3/4" BSW Handnut Type

| Code | Description              | Material                                       |
|------|--------------------------|--|
| 0    | Hexagonal nut            | Stainless steel                                |
| 1    | Low profile              | Naval brass with stainless steel thrust washer |
| 4    | Safebolt                 | Stainless steel                                |
| 5    | Low profile              | Stainless steel                                |
| 8    | Extended                 | Stainless steel                                |
| C    | Extended anti-galling    | Stainless steel with brass thread insert       |
| E    | Low profile anti-galling | Stainless steel with brass thread insert       |

### Eyebolt Length

The code is equivalent to the working length of the bolt. This is calculated from the centre of the eye to the end of the bolt, given in inches.

e.g. **375** = 3.75" (95.25mm)

Eyebolts are available from 49.3mm (2.10") long to 175.3mm (6.90") long.

Refer to the Range tables on page 1 for standard sizes.

THIS PAGE IS INTENTIONALLY BLANK





## Manlid & Inspection Hatch Seals - Introduction

### Accessories & Spare Parts



### Specification

We supply a large range of seals in a selection of sizes and materials for compatibility with many different types of cargo and service conditions. Please contact us if the material you want is not on our data sheet.

If you are ordering a manlid or inspection hatch assembly, we can install the seal if you request this at the time of your order.

We supply three seal types:

- Elastomer Seals
- Composite Seals
- Braided Packing (Non Gas-Tight)

### Elastomer Seals

Seals moulded from rubber compounds are suitable for many types of cargo and service conditions. Some advantages of elastomer seals include:

- easy to clean
- good resilience qualities
- excellent sealing performance
- economical to replace regularly

Please refer to data sheet SPA062 for our standard range of elastomer seals.

### Composite Seals

Composite seals have been developed for general purpose tanks where the cargo can vary, therefore a multi-purpose seal is useful. Advantages of composite seals include:

- easy to clean
- good resilience qualities
- excellent sealing performance
- do not become porous
- suitable for a range of cargoes and temperatures

Please refer to data sheet SPA063 for our standard range of composite seals.

### Composite Seal Types:

#### Super Tanktyt

The Super Tanktyt seal has a rubber core with a PTFE envelope bonded to three sides. There are two types:

- high temperature Nitrile core/PTFE envelope
- EPDM core/PTFE envelope

The Super Tanktyt seal is the ideal choice for the chemical industry. The seal's rubber core gives it the resilience to be gas-tight up to 4 Bar, and the PTFE envelope gives it excellent resistance to hazardous cargoes.

Please refer to data sheet SPA074 for more information about Super Tanktyt manlid seals.

#### Fortyt

The Fortyt seal has a silicone rubber core fully encapsulated with a FEP envelope. There are two types:

- round section
- square section

Please refer to data sheet SPA074 for more information about Fortyt manlid seals.





## Manlid & Inspection Hatch Seals - Introduction

### Accessories & Spare Parts

---

#### Tuffort

The Tuffort seal has a silicone rubber core fully encapsulated with an advanced fluoroplastic envelope which gives the seal increased resilience. There are two types:

- round section
- square section

Please refer to data sheet SPA074 for more information about Tuffort manlid seals.

#### Braided Packing (Non Gas-Tight)

Braided packing is made from PTFE impregnated fibre that is tightly braided. There are two types:

- PTFE braided fibre with silicone core
- PTFE braided fibre (no core)

We supply PTFE braided fibre packing either as a cut length or in a roll for you to cut to the necessary size.

**CAUTION:** Braided packing is a rigid material that will not give a gas-tight seal. The material is lubricant-free but it does contain a small percentage of the wetting agents used during its manufacturing process. Note that small amounts of these wetting agents can leach during use.

For high temperature service conditions, we also supply a Graphite impregnated fibre seal.

Please refer to data sheet SPA064 for our standard range of braided seals.

### Precautions

#### Seal Gas-Tightness

The seal material, the number of manlid bolt fasteners and neckring distortion can affect seal gas-tightness.

For more information, please refer to the linked document below, or contact us.

[View Handnut Torque Guide - Hinged Manlid Assemblies](#)

**CAUTION:** When the neckring has been welded into the vessel, the neckring must be flat to a maximum tolerance of 2mm and round to a maximum tolerance of 4mm. If the neckring is distorted during welding, the manlid assembly will not seal correctly and it can malfunction during operation. Fort Vale accepts no responsibility for distortion caused by welding.

#### Compatibility

**CAUTION:** Make sure that the seal material is compatible with the cargo and the service conditions. This includes, but is not limited to:

- dimensions
- maximum allowable working pressure
- test pressure
- vacuum conditions
- minimum/maximum design temperatures
- materials of construction.



## Manlid & Inspection Hatch Seals - Braided Packing Accessories & Spare Parts



### PTFE Impregnated Braided Fibre

PTFE braided packing is available as a cut length or as a roll of material for you to cut to the necessary size. There are two types:

- PTFE braided fibre with silicone core - see Table 1
- PTFE braided fibre (no core) - see Table 2

**CAUTION:** Braided packing is a rigid material that will not give a gas-tight seal. The material is lubricant-free but it does contain a small percentage of the wetting agents used during its manufacturing process. Note that small amounts of these wetting agents can leach during use.

**Table 1 - With Silicone Core**

| Section (mm) | Length (m) | Part No.      |
|--------------|------------|---------------|
| 14 x 10      | 1.65       | 5005-1410S165 |
| 15 x 10      | 1.65       | 5005-1510S165 |
| 14 x 14      | 1.65       | 5005-1414S165 |
| 14 x 14      | 50         | 5005-1414SR50 |
| 15 x 15      | 1.65       | 5005-1515S165 |
| 16 x 16      | 1.75       | 5005-1616S175 |
| 16 x 16      | 30         | 5005-1616SR30 |

**Table 2 - No Silicone Core**

| Section (mm) | Length (m) | Part No.      |
|--------------|------------|---------------|
| 14 x 10      | 1.65       | 5005-1410D165 |
| 15 x 10      | 1.65       | 5005-1510D165 |
| 14 x 14      | 1.65       | 5005-1414D165 |
| 14 x 14      | 50         | 5005-1414DR50 |
| 15 x 15      | 1.65       | 5005-1515D165 |
| 16 x 16      | 1.75       | 5005-1616D175 |
| 16 x 16      | 30         | 5005-1616DR30 |



### Related Parts

| Description                                      | Part No. |
|--|----------|
| Mitre seal cutter - for use with braided packing | 400/3100 |

### Graphite Impregnated Braided Fibre

**CAUTION:** Braided packing is a rigid material that will not give a gas-tight seal.

| Material   | Compatibility (Example Only) & Minimum/Maximum Temperature                                | Pendle Manlid Seal Part Number & Section Dimension (mm) |                          |                          | Euro Lid Seal        |
|--|---|---|--------------------------|--------------------------|----------------------|
|  |   | 300mm (12")   | 500mm (20")              | 600mm (24")              | 500mm (20")          |
| <b>Graphite Impregnated Fibre</b> (Non-asbestos) | Non-corrosive high temperature cargo e.g. tar, bitumen<br>-50°C to 250°C (-58°F to 482°F) | 5005-30GA<br>14.2 x 14.2                                | 5005-50GA<br>14.2 x 14.2 | 5005-60GA<br>14.2 x 14.2 | 5005-53GA<br>16 x 16 |

### Compatibility

**CAUTION:** The compatibility information in the table is for general guidance only. Make sure that the seal material is compatible with the cargo and the service conditions. This includes, but is not limited to:

- dimensions
- maximum allowable working pressure
- test pressure
- vacuum conditions
- minimum/maximum design temperatures
- materials of construction.

For our standard range of elastomer seals and composite seals, please refer to data sheet SPA062 and SPA063.



# Manlid & Inspection Hatch Seals - Composite Seals

## Accessories & Spare Parts

### Composite Seals

The table shows our standard range. For more information about composite seals, please refer to data sheet SPA074.

If the material you need is not shown, please contact Fort Vale. For our standard range of elastomer seals and braided packing, please refer to data sheet SPA062 and SPA064.

| Material   | Compatibility (Example Only) & Minimum/Maximum Temperature                      | Pendle Manlid Seal                   |                           |                                      |                           |                                      |                     | Euro Lid Seal |
|--|---|--------------------------------------|---------------------------|--------------------------------------|---------------------------|--------------------------------------|---------------------|---------------|
|  |   | Part Number & Section Dimension (mm) |                           | Part Number & Section Dimension (mm) |                           | Part Number & Section Dimension (mm) |                     |               |
|  |   | 170mm (7")                           | 300mm (12")               | 460mm (18")                          | 500mm (20")               | 600mm (24")                          | 500mm (20")         |               |
| <b>Fortyt Round section</b><br>Silicone/FEP        | Corrosive cargo - resistance similar to PTFE<br>-60°C to 205°C (-76°F to 401°F) |                                      | 5005-30FT<br>Ø14.10       |                                      | 5005-50FT<br>Ø15          |                                      |                     |               |
| <b>Fortyt Square section</b><br>Silicone/FEP       | Corrosive cargo - resistance similar to PTFE<br>-60°C to 205°C (-76°F to 401°F) |                                      | 5005-30FTSQ<br>14 x 12    |                                      | 5005-50FTSQ<br>14 x 12    |                                      |                     |               |
| <b>Fortyt Square section</b><br>White silicone/FEP | Corrosive cargo - resistance similar to PTFE<br>-40°C to 205°C (-40°F to 401°F) |                                      |                           |                                      | 5005-50FTSQWS<br>14 x 12  |                                      |                     |               |
| <b>Super Tanktyt</b><br>Nitrile core               | Corrosive cargo - resistance similar to PTFE<br>-25°C to 140°C (-13°F to 284°F) |                                      | 5005-890<br>15 x 10       | 5005-870<br>14.5 x 10                | 5005-860<br>14.5 x 12     | 5005-850<br>16 x 10                  | 5005-871<br>16 x 16 |               |
| <b>Super Tanktyt</b><br>EPDM core                  | Corrosive cargo - resistance similar to PTFE<br>-50°C to 150°C (-58°F to 302°F) | 5005-830EP<br>15.5 x 10              | 5005-890EP<br>15 x 10     | 5005-870EP<br>14.5 x 10              | 5005-860EP<br>14.5 x 12   | 5005-850EP<br>15 x 10                |                     |               |
| <b>Tuffort D Section</b><br>Silicone/FEP           | Corrosive cargo - resistance similar to PTFE<br>-60°C to 160°C (-76°F to 320°F) |                                      | 5005-30TUF<br>15.1 x 12.5 |                                      | 5005-50TUF<br>15.1 x 12.5 |                                      |                     |               |
| <b>PFA</b><br>White silicone/<br>PFA               | Corrosive cargo - resistance similar to PTFE<br>-40°C to 260°C (-40°F to 500°F) |                                      | 5005-30PFA<br>Ø15         |                                      | 5005-50PFA<br>Ø15         |                                      |                     |               |

### Compatibility

**CAUTION:** The compatibility information in the table is for general guidance only. Make sure that the seal material is compatible with the cargo and the service conditions. This includes, but is not limited to:

- dimensions
- maximum allowable working pressure
- test pressure
- vacuum conditions
- minimum/maximum design temperatures
- materials of construction.



# Manlid & Inspection Hatch Seals - Elastomer Seals

## Accessories & Spare Parts

### Elastomer Seals

The table shows our standard range. Our elastomer seals are colour-coded to identify the material. The applicable colour is marked on the outer edge of the seal.

If the material you need is not shown, please contact Fort Vale. For our standard range of composite seals and braided packing, please refer to data sheet SPA063 and SPA064.

| Material             | Compatibility (Example Only) & Minimum/Maximum Temperature  | Pendle Manlid Seal                   |                                      |                                      | Euro Lid Seal                        |                                      |                                      | Colour Code |
|----------------------|---|--------------------------------------|--------------------------------------|--------------------------------------|--------------------------------------|--------------------------------------|--------------------------------------|-------------|
|                      |   | Part Number & Section Dimension (mm) | Part Number & Section Dimension (mm) | Part Number & Section Dimension (mm) | Part Number & Section Dimension (mm) | Part Number & Section Dimension (mm) | Part Number & Section Dimension (mm) |             |
| Butyl                | Non-corrosive cargo<br>-40°C to 120°C (-40°F to 248°F)  | 170mm (7")                           | 500mm (20")                          | 600mm (24")                          | 300mm (12")                          | 460mm (18")                          | 500mm (20")                          | Blue        |
|                      |   | 5005-17B<br>16 x 10                  | 5005-50B<br>15.24 x 11.8             | 5005-60B<br>15.25 x 10               | 5005-33B<br>16 x 16                  | 5005-47B<br>16 x 16                  | 5005-53B<br>16 x 16                  |             |
| EPDM                 | Some corrosive cargoes. Do not use with petroleum-cased cargo<br>-50°C to 150°C (-58°F to 302°F)    | 5005-17EPD<br>16 x 10                | 5005-50EPD<br>15.24 x 11.8           | 5005-60EPD<br>15.25 x 10             | 5005-33EPD<br>16 x 16                | 5005-47EPD<br>16 x 16                | 5005-53EPD<br>16 x 16                | Red/Blue    |
|                      |   | 5005-17CSM<br>16 x 10                | 5005-50CSM<br>15.24 x 11.8           | 5005-60CSM<br>15.25 x 10             | 5005-33CSM<br>16 x 16                | 5005-47CSM<br>16 x 16                | 5005-53CSM<br>16 x 16                |             |
| CSM                  | Moderately corrosive cargo. Do not use with petroleum-cased cargo<br>-40°C to 85°C (-40°F to 185°F) | 5005-17CSM<br>16 x 10                | 5005-50CSM<br>15.24 x 11.8           | 5005-60CSM<br>15.25 x 10             | 5005-33CSM<br>16 x 16                | 5005-47CSM<br>16 x 16                | 5005-53CSM<br>16 X 16                | White       |
| Natural White Rubber | Food products<br>-50°C to 80°C (-58°F to 176°F)   | 5005-17SWR<br>16 x 10                | 5005-50SWR<br>15.24 x 11.8           | 5005-60SWR<br>15.25 x 10             | 5005-33SWR<br>16 x 16                | 5005-47SWR<br>16 x 16                | 5005-53SWR<br>16 x 16                | Green       |
|                      |   | 5005-17NR<br>16 x 10                 | 5005-50NR<br>15.24 x 11.8            | 5005-60NR<br>15.25 x 10              | 5005-33NR<br>16 x 16                 | 5005-47NR<br>16 x 16                 | 5005-53NR<br>16 x 16                 |             |
| Neoprene             | Non-corrosive cargo<br>-30°C to 100°C (-22°F to 212°F)  | 5005-17N<br>16 x 10                  | 5005-50N<br>15.24 x 11.8             | 5005-60N<br>15.25 x 10               | 5005-33N<br>16 x 16                  | 5005-47N<br>16 x 16                  | 5005-53N<br>16 x 16                  | Red         |
| Nitrile (Black)      | Aliphatic hydrocarbons<br>-25°C to 100°C (-13°F to 212°F)   | 5005-17N<br>16 x 10                  | 5005-50N<br>15.24 x 11.8             | 5005-60N<br>15.25 x 10               | 5005-33N<br>16 x 16                  | 5005-47N<br>16 x 16                  | 5005-53N<br>16 x 16                  | Red         |
| Orange Silicone      | High temperature non-corrosive cargo<br>-50°C to 200°C (-58°F to 392°F)                             | 5005-17S<br>16 x 10                  | 5005-50S<br>15.24 x 11.8             | 5005-60S<br>15.25 x 10               | 5005-33S<br>16 x 16                  | 5005-47S<br>16 x 16                  | 5005-53S<br>16 x 16                  | Red         |
| White Silicone       | Food products. FDA approved<br>-50°C to 200°C (-58°F to 392°F)                                      | 5005-17WS<br>16 x 10                 | 5005-50WS<br>15.24 x 11.8            | 5005-60WS<br>15.25 x 10              | 5005-33WS<br>16 x 16                 | 5005-47WS<br>16 x 16                 | 5005-53WS<br>16 x 16                 |             |
| Viton A              | Moderately corrosive cargo<br>-15°C to 200°C (5°F to 392°F)   | 5005-17VR<br>16 x 10                 | 5005-50VR<br>15.24 x 11.8            | 5005-60VR<br>15.25 x 10              | 5005-33VR<br>16 x 16                 | 5005-47VR<br>16 x 16                 | 5005-53VR<br>16 x 16                 | Yellow      |

### Compatibility

**CAUTION:** The compatibility information in the table is for general guidance only. Make sure that the seal material is compatible with the cargo and the service conditions. This includes, but is not limited to:

- dimensions
- maximum allowable working pressure
- test pressure
- vacuum conditions
- minimum/maximum design temperatures
- materials of construction.



## How to Install a Manlid/Inspection (Access) Hatch Seal Installation Instructions



Check that the seal material is compatible with the cargo and the service conditions.

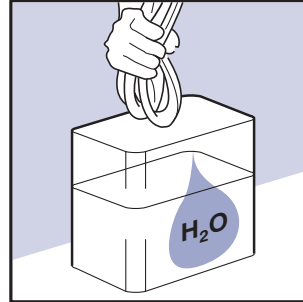

**ELASTOMER SEAL:** Put the seal momentarily into clean, cold water.

**PRECAUTIONS:** Examine the seal and the seal groove. Make sure all surfaces are clean with no corrosion, debris or damage. **CAUTION:** Do not use a damaged part.

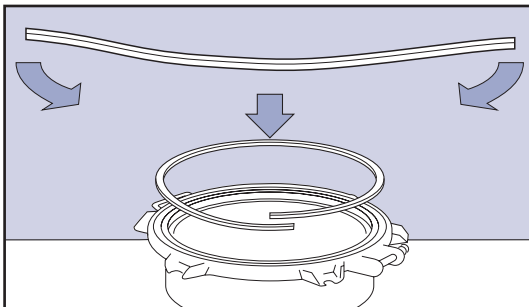

**BRAIDED PACKING:** Measure the packing around the circumference of the seal groove to get the correct size.

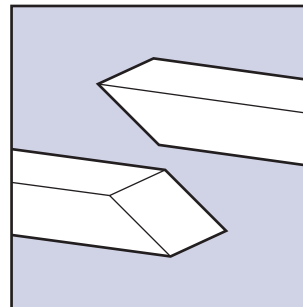

**BRAIDED PACKING:** Cut the seal with a mitre joint. If necessary, apply PTFE tape to the joint.  
**NOTE:** We do not recommend the use of adhesive.

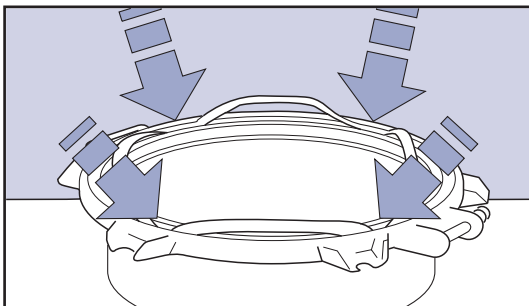

**Step 1.** Put the cover with the seal groove face up. Push the seal into the groove at 4 points, 90° to each other. Make sure the seal is not twisted.

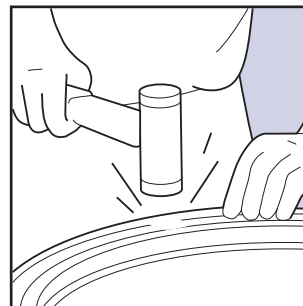

**Step 2.** Use a plastic or wooden mallet to hit the seal and install it into the groove.  
**CAUTION:** Do not use a metal hammer.

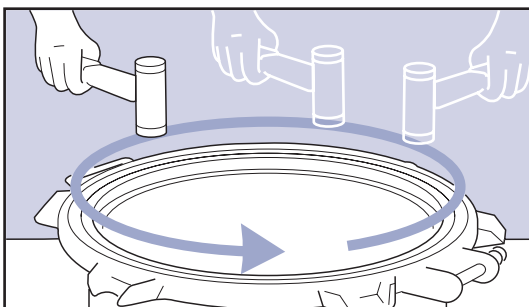

**Step 3.** Continue around the full circumference of the seal until it is fully installed.

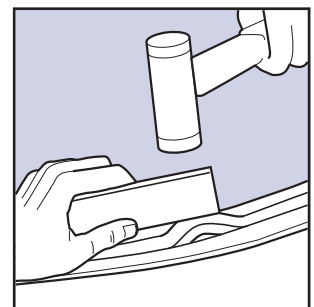
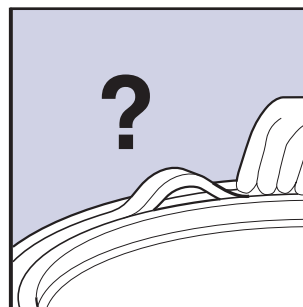

**Step 4.** If a kink occurs in the seal, use a small piece of clean seal material and the mallet to install the seal correctly. Check again to make sure the installation is satisfactory. The procedure is complete.



---

# APPENDIX

## Manlid & Inspection Hatch Assemblies

### Catalogue

---

---

|   |   |
|---|---|
| A | Handnut Torque Guide - Hinged Manlid Assemblies     |
| B | Client Responsibilities - Manlid/Inspection Hatches |

---

THIS PAGE IS INTENTIONALLY BLANK



# Handnut Torque Guide - Hinged Manlid Assemblies

## Installation & Operating Instructions

### Operating Conditions

- When the vessel is in service, all the swingbolt assemblies on the manlid or inspection hatch assembly must be correctly installed and in the closed position.
- Obey the given Handnut Torque Values.
- Make sure that the seal material is compatible with the cargo and the vessel operating conditions.

### Handnut Torque Values

If the manlid cover is marked with a maximum torque value, obey that torque value. If there is no torque value on the manlid cover, obey the torque values given in Table MT1. To apply the recommended handnut torque, use a handnut torque adaptor, part number 495/10T0 and a torque wrench.

**NOTE:** The information given in Table MT1 is applicable to round, hinged manlid assemblies only. This information is not applicable to flat bolted or elliptical manlid assemblies.

**Table MT1 - Manlid Maximum Recommended Torque Values**

| Manlid Cover Type   | MAWP          | Handnut Maximum Recommended Torque   |
|---------------------|---------------|--|
| Single skin         | 2.67 Bar      | 68 Nm (50 Lb.ft)   |
| EN14025 double skin | 3 Bar & 4 Bar | 93.2 Nm (68.7 Lb.ft)<br><b>NOTE:</b> Some seals are not compatible - See <b>SEAL CAUTION</b> |
| ASME double skin    | 3 Bar & 4 Bar | 118 Nm (87 Lb.ft)<br><b>NOTE:</b> Some seals are not compatible - See <b>SEAL CAUTION</b>    |
| All other manlids   | -             | 50 Nm (37 Lb. ft)  |

**SEAL CAUTION:** Some seal materials are not compatible with the Handnut Maximum Recommended Torque value for the Manlid Cover Type given in Table MT1. Please refer to Table MT2 - Seal Maximum Recommended Torque Values. Do not torque the handnuts more than the Handnut Maximum Recommended Torque value applicable to the seal material type. Too much tightening force can cause damage to the seal, which can cause the manlid assembly to leak.

**Table MT2 - Seal Maximum Recommended Torque Values**

| Seal Material Type                               | Tank Type | Handnut Maximum Recommended Torque         |
|--|-----------|--|
| Braided Packing                                  | EN14025   | 93.2 Nm (68.7 Lb.ft)                       |
|  | ASME      | 118 Nm (87 Lb.ft)                          |
| Composite<br>E.g. Super Tanktyt, Tuffort, Fortyt | N/A       | 68 Nm (50 Lb.ft) - See <b>SEAL CAUTION</b> |
| Elastomers<br>E.g. Viton, EPDM                   | N/A       | Will seal at 20 Nm (14.8 Lb.ft)            |
|  | EN14025   | 93.2 Nm (68.7 Lb.ft)                       |
|  | ASME      | 118 Nm (87 Lb.ft)                          |

### Handnut Torque Conditions

The given Handnut Maximum Recommended Torque values are based on:

- unlubricated swingbolt assemblies.
- a neckring that is flat to a tolerance of 2mm.
- a neckring that is round to a tolerance of 4mm.

If a lubrication is used, the Handnut Maximum Recommended Torque values will decrease.

**CAUTION:** If the neckring flatness and roundness does not obey the permitted tolerances, the manlid cover and neckring seal faces will not align correctly and the assembly will leak. Fort Vale accepts no responsibility for distortion caused by welding.

**NOTE:** Bolt stress can decrease after initial tightening. The cause of this can be deformation of the seal, particularly with soft materials such as elastomers. We recommend that you check the handnut torque again after a period of time - a minimum of 4 hours.





## Client Responsibilities - Manlid/Inspection (Access) Hatches Installation, Operation & Maintenance Instructions

### Pressure Equipment Design Requirements

Make sure that the access hatch assembly has sufficient compensation to obey the pressure equipment calculations and standards. Add more compensation if necessary.

### Pressure Release

Make sure that personnel who will operate the access hatch know that there is a risk of injury or death if an access hatch is opened when there is pressure inside the vessel. We recommend that you install a "safebolt" fastener to the assembly as protection against pressure release. Contact Fort Vale for information.

### Compatibility

Make sure that the function and technical specification of the access hatch assembly and seal is compatible with the vessel service conditions and the cargo. This includes, but is not limited to:

- dimensions.
- maximum allowable working pressure.
- test pressure.
- vacuum conditions.
- minimum/maximum design temperatures.
- materials of construction.

### Maintenance

Fort Vale access hatch assemblies have a long life if you use them correctly in compatible service conditions. It is not necessary to lubricate the parts, but we recommend that you do the inspections that follow:

#### Inspections before each load of cargo:

**Cover:** Examine the hinge assembly, all brackets and all swingbolt assemblies to make sure there is no damage or corrosion. Make sure there are no parts missing.

**Swingbolts:** Examine the swingbolt threads to make sure they are clean and that there is no wear. Check for correct operation. Make sure there are no parts missing.

**Seal:** Examine around the seal circumference to make sure it is clean and that there is no damage to the material. Make sure that the seal material is compatible with the cargo and service conditions. Check that the seal is correctly installed.

**Neckring:** Examine all brackets to make sure there is no damage or corrosion. Examine the circumference of the neckring sealing surface to make sure it is clean and flat, and that there is no damage.

**CAUTION:** If you operate the access hatch assembly with very corrosive cargo, or near its temperature and/or pressure limit (very high or very low temperature and/or pressure), do the inspections more frequently.

Also, schedule regular maintenance based on how frequently the access hatch is used, the type of cargo and the service conditions.

### Replacement Parts

Do not adapt or change the access hatch assembly. If you install a replacement part, it must be a genuine Fort Vale part.

**WARNING:** If you install a part that is not genuine, there is a risk of:

- injury to personnel.
- permanent damage to the access hatch assembly.
- permanent damage to the vessel.
- access hatch assembly malfunction.

### Compatibility of Accessories

Accessory components must cause no interference with the access hatch function. Accessories must be made from compatible materials that will cause no damage to the access hatch materials. Do not install an accessory that will cause an increased load on the access hatch, such as mechanical, static, dynamic or thermal load.

### Mis-use

Obey the instructions and recommended procedures in the installation and operating instructions. Obey the pressure and temperature markings on the access hatch assembly and on the drawing. Use the access hatch assembly for its correct function only. Fort Vale accept no liability or responsibility for incorrect use of the assembly.



Our subsidiaries are located in:

**US Office**

126 N. Virginia  
La Porte  
TX 77571  
USA

Tel: +1 281 471 8100

Fax: +1 281 471 8116

Email: [ussales@fortvale.com](mailto:ussales@fortvale.com)

**Head Office**

Calder Vale Park  
Simonstone Lane  
Simonstone, Burnley  
Lancashire, BB12 7ND, UK

Tel: +44 (0) 1282 687120

Fax: +44 (0) 1282 687110

Email: [sales@fortvale.com](mailto:sales@fortvale.com)

**China Office**

Fort Vale Engineering Shanghai Ltd  
Building 11 88 Yuanshan Road  
Xinzhuang Industry Park  
Shanghai 201108 China

Tel: +86 21 6442 1367

Fax: +86 21 6442 1376

Email: [cnsales@fortvale.com](mailto:cnsales@fortvale.com)

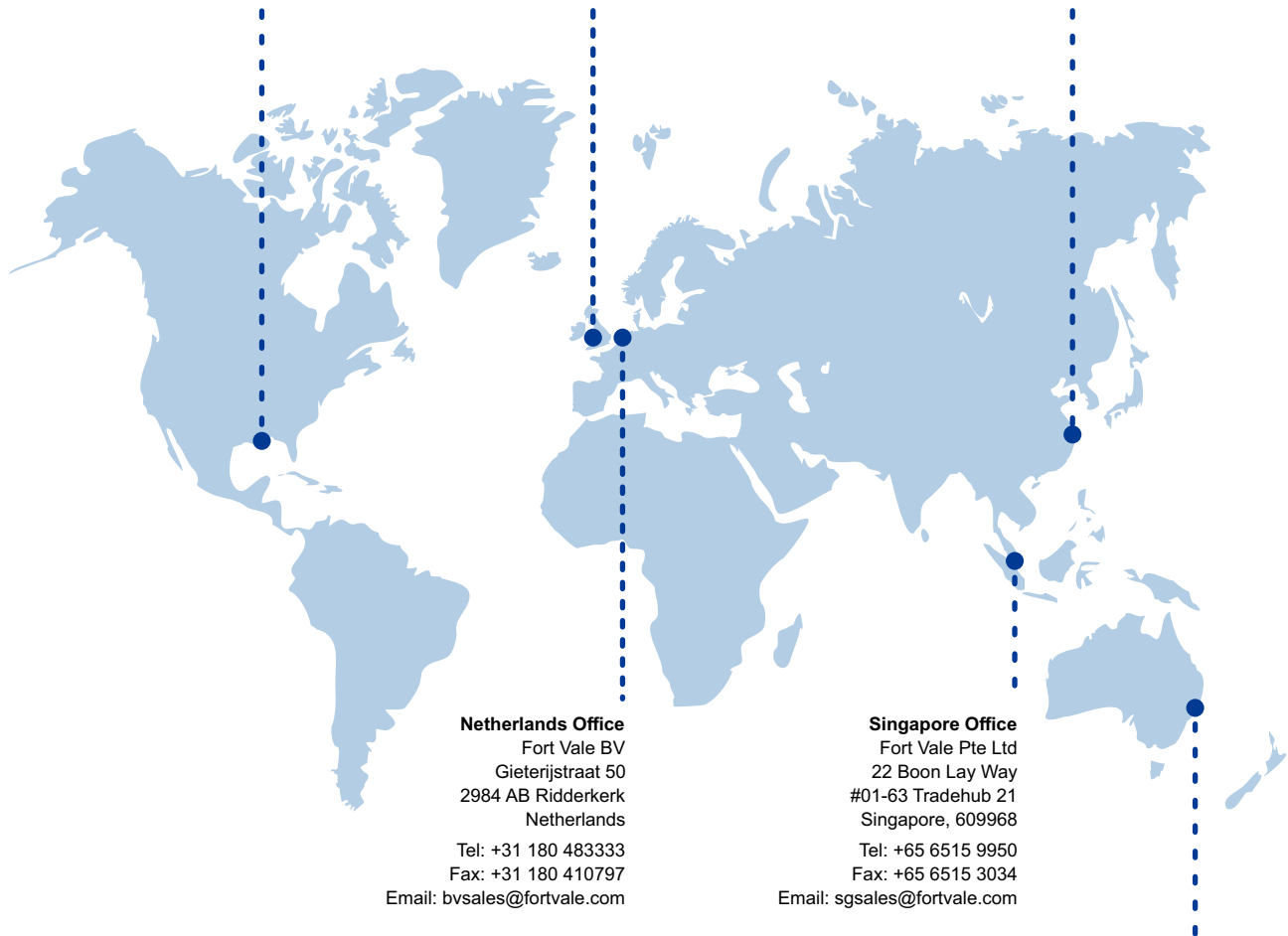

**Netherlands Office**

Fort Vale BV  
Gieterijstraat 50  
2984 AB Ridderkerk  
Netherlands

Tel: +31 180 483333

Fax: +31 180 410797

Email: [bvsales@fortvale.com](mailto:bvsales@fortvale.com)

**Singapore Office**

Fort Vale Pte Ltd  
22 Boon Lay Way  
#01-63 Tradehub 21  
Singapore, 609968

Tel: +65 6515 9950

Fax: +65 6515 3034

Email: [sgsales@fortvale.com](mailto:sgsales@fortvale.com)

**Australia Office**

Fort Vale Australia Pty Ltd  
Bellwood Business Park  
Unit 14, 49 Bellwood Street  
Darra, Queensland, 4076

Tel: +61 7 3189 5059

Email: [ausales@fortvale.com](mailto:ausales@fortvale.com)

We also have Authorised Distributors around the world to provide you with product sales and after-market services. To find your nearest distributor, please visit our website - [www.fortvale.com](http://www.fortvale.com)

