



Specification

Nominal size/body angle

4" / 90°

Inlet connection

Flanged: 8 x 18mm holes on a 210mm PCD

Outlet connection

Flanged: 8 x 18mm holes on a 180mm PCD

Properties

With pneumatic actuator

Materials

Seating area: Superseat (alloy 625)

Contact parts: 316 stainless steel

Main seal: Fortyt

Alternatives are available, refer to the Design Options page

Design Conditions

Weight:	32.0 Kg
Design Pressure (MAWP):	4 Bar
Test Pressure:	7.3 Bar
Design Temperature Min:	-40°C
Design Temperature Max:	200°C

NOTE: The Design Conditions and Section View dimensions are for the specified part number only.

Approvals

BS EN14433

Range

Description	Part No.
Standard valve	875/4800SS
With replaceable seat inlet	875/4800SSRX
With replaceable seat inlet, conical poppet, steam chamber	875/4800SSHRX

Related Parts

Description	Part No.
Weld-in flange	854/9000
Stud kit (875/4800SS only)	875/2044
CNAF/PTFE inlet gasket	5005-467
CNAF/PTFE outlet gasket	5005-468
Mating flange - DIN100 PN16	875/4150
Valve operation decal	845/0320

Section View

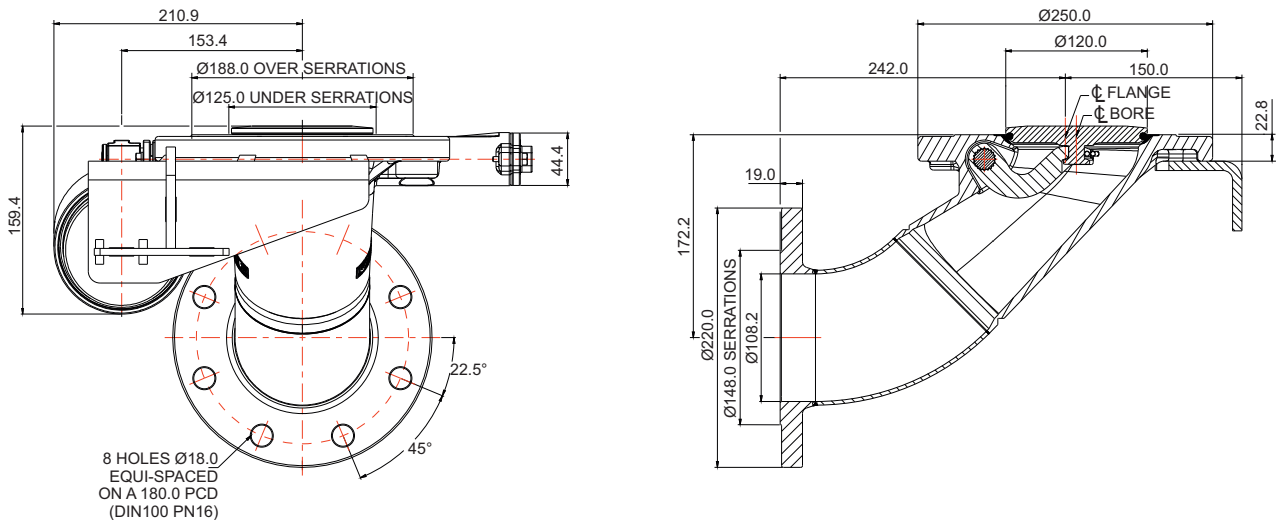

Parts Drawing

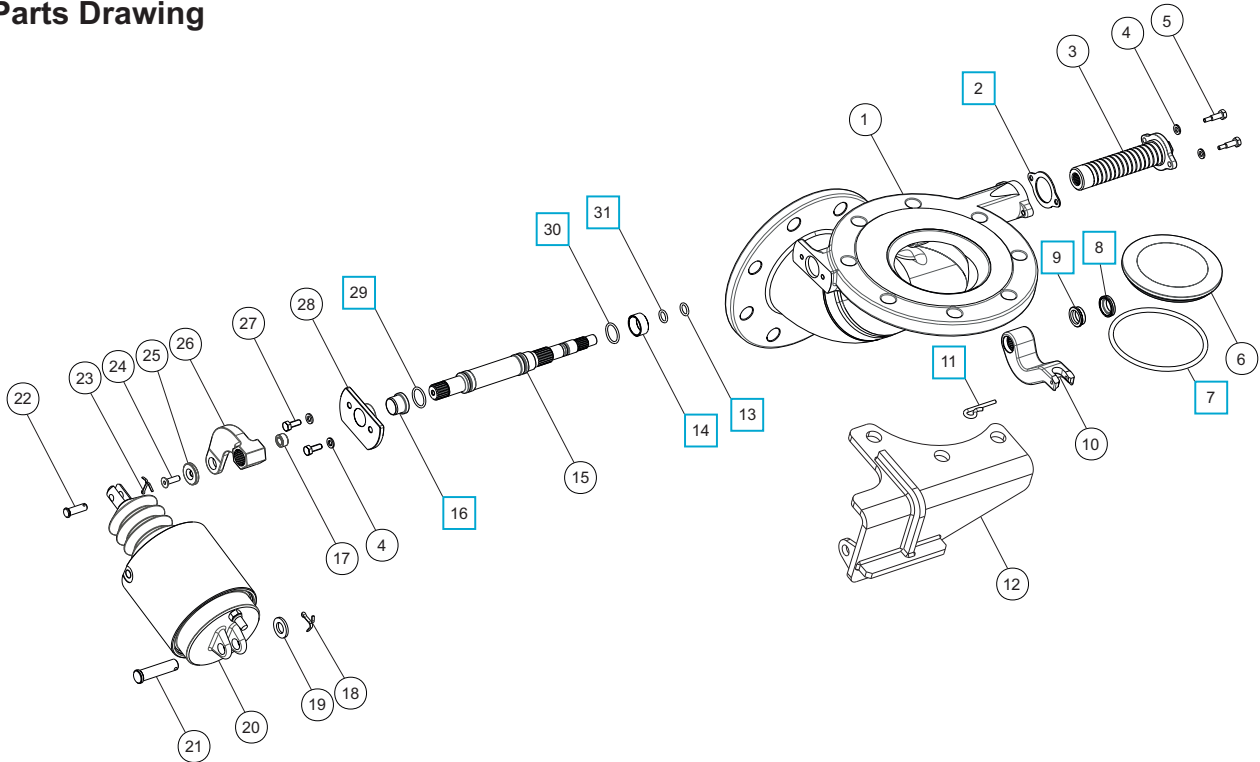

Parts List

Item	Description	Part No.
1	Body	875/4110B
2	Spring boss gasket	5005-846 <input type="checkbox"/>
3	Spring assembly	875/0050
4	Spring washer (4)	5113-008
5	Clamp screw (2)	845/0017
6	Poppet	875/0040
7	Fortyt O ring	5005-349 <input type="checkbox"/>
8	PTFE bottom bush seal	845/0064 <input type="checkbox"/>
9	Bottom seal energizer	845/0063 <input type="checkbox"/>
10	Lifting fork	875/0010
11	Retaining pin	845/0015 <input type="checkbox"/>
12	Pneumatic cylinder bracket	845/8064
13	Perfluoroelastomer O ring	10133PHT <input type="checkbox"/>
14	PTFE spindle bearing	845/0062 <input type="checkbox"/>
15	Main spindle	875/0200
16	PTFE spindle stuffing seal	845/0061 <input type="checkbox"/>
17	Bronze bush	844/2011
18	Split pin	5220-008
19	Plain washer	5113-006
20	Pneumatic cylinder	875/2125
21	Clevis pin	875/2122
22	Clevis pin	844/2121
23	Split pin	5118-016
24	Countersunk bolt	5111-019

Parts List

Item	Description	Part No.
25	Retaining washer	20370/2
26	Crank arm	844/2049
27	Hex bolt (2)	5111-022
28	Stuffing clamp flange	845/0066
29	Viton O ring	5005-336 <input type="checkbox"/>
30	Perfluoroelastomer O ring	5005-384 <input type="checkbox"/>
31	PTFE O ring	5005-008 <input type="checkbox"/>

Seal Kit

Description	Part No.
All parts marked <input type="checkbox"/> in the Parts List	875/00SK