

Specification

Inlet nominal size

150mm

Outlet connection

100mm NB weld prepared, machined with a shear groove

Operation

Manually operated by a handwheel. The handwheel assembly has a fixed splash-guard, a padlock security system and a machined shear groove

Materials

Contact parts: 304/316 stainless steel

Spindle: 1.4462 duplex steel

Main seal: RTFE

Design Conditions

Weight:	65 Kg
Design Pressure (MAWP):	3.5 Bar
Test Pressure:	5.25 Bar
Design Temperature Min:	-20°C
Design Temperature Max:	250°C

NOTE: The Design Conditions and Section View dimensions are for the specified part number only.

Approvals

BS EN14433

Related Parts

Description	Part No.
100mm butterfly valve with hemispherical closure plate - manually operated	468/75HTB
100mm butterfly valve with hemispherical closure plate - pneumatically actuated	468/75HTBPN

Section View

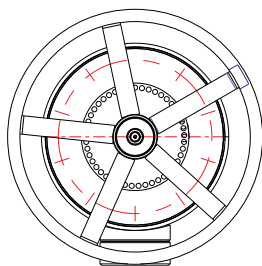

Valve shown in the CLOSED position

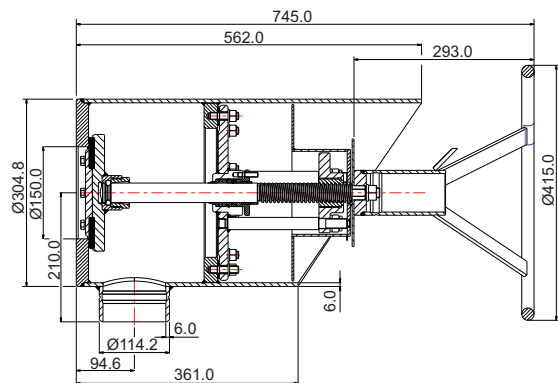

Valve shown in the OPEN position

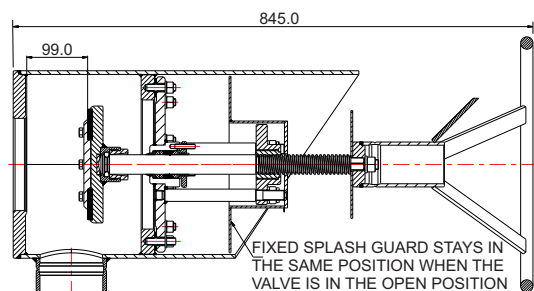

Parts Drawing: Internal Sub-Assembly

Part No: 262/2150

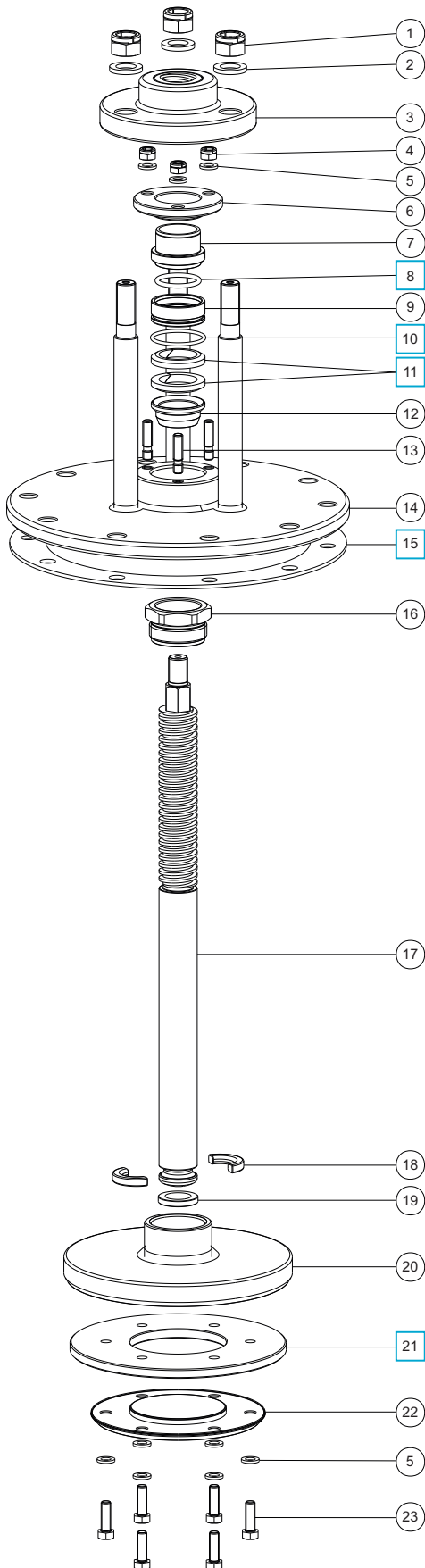

Parts List

Item	Description	Part No.
1	M16 self-locking nut (3)	5112-053
2	M16 spring washer (3)	5113-012
3	Threaded flange assembly	262/1037
4	M8 self-locking nut (3)	5112-031
5	M8 spring washer (9)	5113-003
6	Stuffing clamp	262/1035
7	Packing clamp bush	262/1051
8	Viton O ring	ORB218VR <input type="checkbox"/>
9	Wiper bearing	262/1052
10	Viton O ring	ORB129VR <input type="checkbox"/>
11	Gland packing (2)	262/1024 <input type="checkbox"/>
12	Wiper bearing	262/1049
13	M8 x 33mm stud	S0396/10
14	Tie bar weld assembly	262/1059
15	Sigma gasket *Note	262/1007 <input type="checkbox"/>
16	Stuffing nut	262/1033
17	Spindle	262/2003
18	Thrust bearing pair	262/1028
19	Thrust bearing	262/1027
20	Poppet	262/1013
21	Poppet seal disc	262/1026 <input type="checkbox"/>
22	Seal clamp plate	262/1025
23	M8 x 25mm hex bolt (6)	5111-048

NOTE: Item 15 Sigma gasket 262/1007 is not included in the internal sub-assembly 262/2150. Please order it separately.

Seal Kit

Description	Part No.
All parts marked <input type="checkbox"/> in the Parts List	262/20SK