



Catalogue

Standard Range of Butterfly Valves



CONTENTS

Butterfly Valves

Catalogue

Airline Butterfly Valves

Design Options: Airline Ball Valves & Butterfly Valves	3
2" BSP Airline Butterfly Valve	5
2" Flanged Airline Butterfly Valve	7

Accessories: Airline Valves

Pressure Gauges	9
Weld-In Flanges for Airline Valves	10
Installation Options: Airline Ball Valves & Airline Butterfly Valves	11

Discharge Butterfly Valves

Design Options: Discharge Butterfly Valves	13
2" Clamped Widdop Butterfly Valve	15
3" Clamped Widdop Butterfly Valve	17
3" Clamped Widdop Butterfly Valve - High Temperature	19
3" Clamped Widdop Butterfly Valve - Pneumatically Actuated	21
3" Clamped Widdop Butterfly Valve - Solidifying Cargo	23
3" Flanged Widdop Butterfly Valve	25
3" Flanged Widdop Butterfly Valve: Dual Drilled Inlet	27
TW80 Clamped Butterfly Valve	29

Continued over



CONTENTS

Butterfly Valves

Catalogue

4" Clamped Butterfly Valve	31
TW100 Clamped Butterfly Valve	33
6" Clamped Butterfly Valve	35
Installation Options: Top Discharge Assembly	37
Installation Options: Bottom Discharge Assembly	38
Discharge Butterfly Valves: Road Tanker Specification	
Design Options: Discharge Butterfly Valves: Road Tanker Specification	39
3" Tankpro Butterfly Valve	41
3" Unify Valve	43
Appendix	
Bolt Torque Guide & Step Loading Procedure	47
Client Responsibilities	49
Fort Vale Worldwide	51



Airline Ball Valves & Butterfly Valves

Design Options

Function

An airline valve is used when the tank is pressurised during testing or discharge and can be used for inert gas blanketing or vapour recovery. We offer ball valves and butterfly valves for airline connections.

Design Options

The design options below are available on our standard range of airline valves.

Nominal Bore

40mm (1½"): Ball valves

50mm (2"): Ball valves & butterfly valves

Special service conditions:

Reduced bore e.g. 25mm (1")

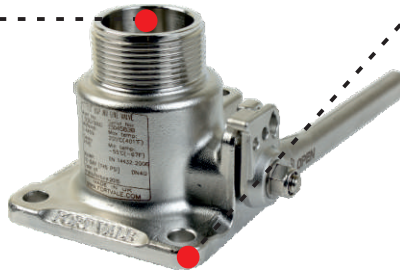

Tank Connection

Flanged: 4 holes

Different drilling patterns

Operation

Manually operated: A range of handles is available

Pneumatically actuated

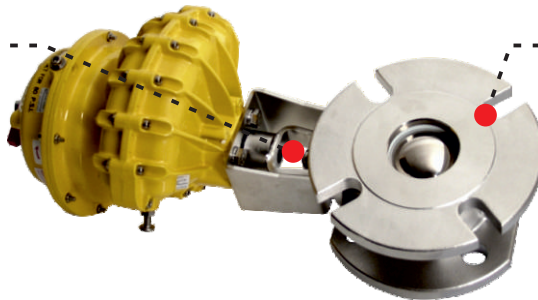

Outlet / Process Connection

Threaded: 1½" BSP, 2" BSP

Dual threaded: 1½" BSP/1½" NPT

Flanged: Closed or open slots

Valve Materials

316 stainless steel

Special service conditions:

Lined wetted parts, e.g. PFA

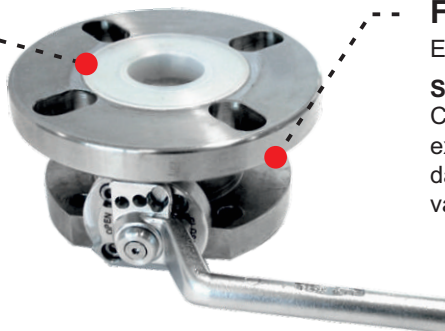

Finish

Electropolished

Special service conditions:

Corrosion-resistant paint on external surfaces to prevent damage from corrosive cargo vapour/splash

Accessories

Gauge guard

Gauze or sintered filter

TIR to gauge inlet plug

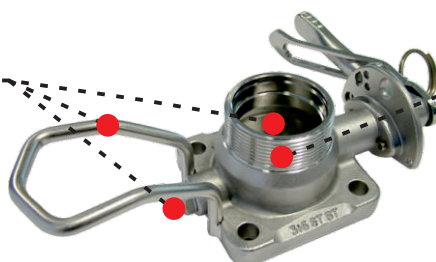

Main Seal

PTFE

Special service conditions:

High-temperature compatible seals



Airline Ball Valves & Butterfly Valves

Design Options

Related Parts

We recommend our range of compatible accessories:

- Pressure gauges
- Filters: gauzed or sintered
- Blank caps
- Flanges - weld-in and adaptor
- Fasteners
- Gaskets

Please contact us for more information about these parts.



2" BSP Airline Butterfly Valve

Part No: 535/0200



Specification

Nominal size

50mm

Tank connection

Flanged: 4 x 10.9mm holes on a 100mm PCD

Outlet/Process connection

Threaded: 2" BSP male

Properties

1/4" BSP gauge connection, gauge guard, handle with TIR

Materials

Contact parts: 316 stainless steel

Main seal: PTFE

Alternatives are available, refer to the Design Options page

Design Conditions

Weight:	3.7 Kg
Design Pressure (MAWP):	6.9 Bar
Test Pressure:	12.5 Bar
Design Temperature Min:	-40°C
Design Temperature Max:	190°C

NOTE: The Design Conditions and Section View dimensions are for the specified part number only.

Design Code

BS EN14432

Range

Description	Part No.
Standard specification	535/0200
With gauze filter	535/0200F
With sintered filter	535/0200S

Related Parts

Description	Part No.
Dust cap	10301PS
Pressure gauge	920/07BBSP
Gauge adaptor	352/4004
Stud kit	350/1300
Gasket	5005-500
Weld-in flange	355/1000

Section View

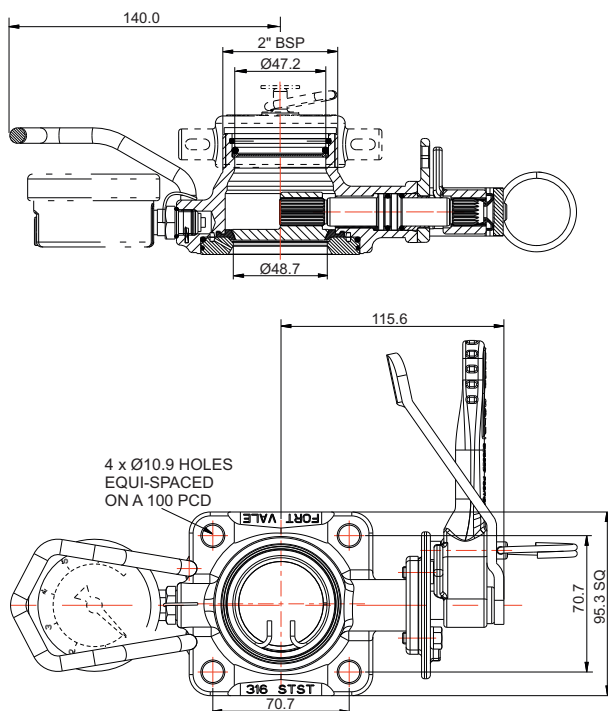



2" BSP Airline Butterfly Valve

Part No: 535/0200

Parts Drawing

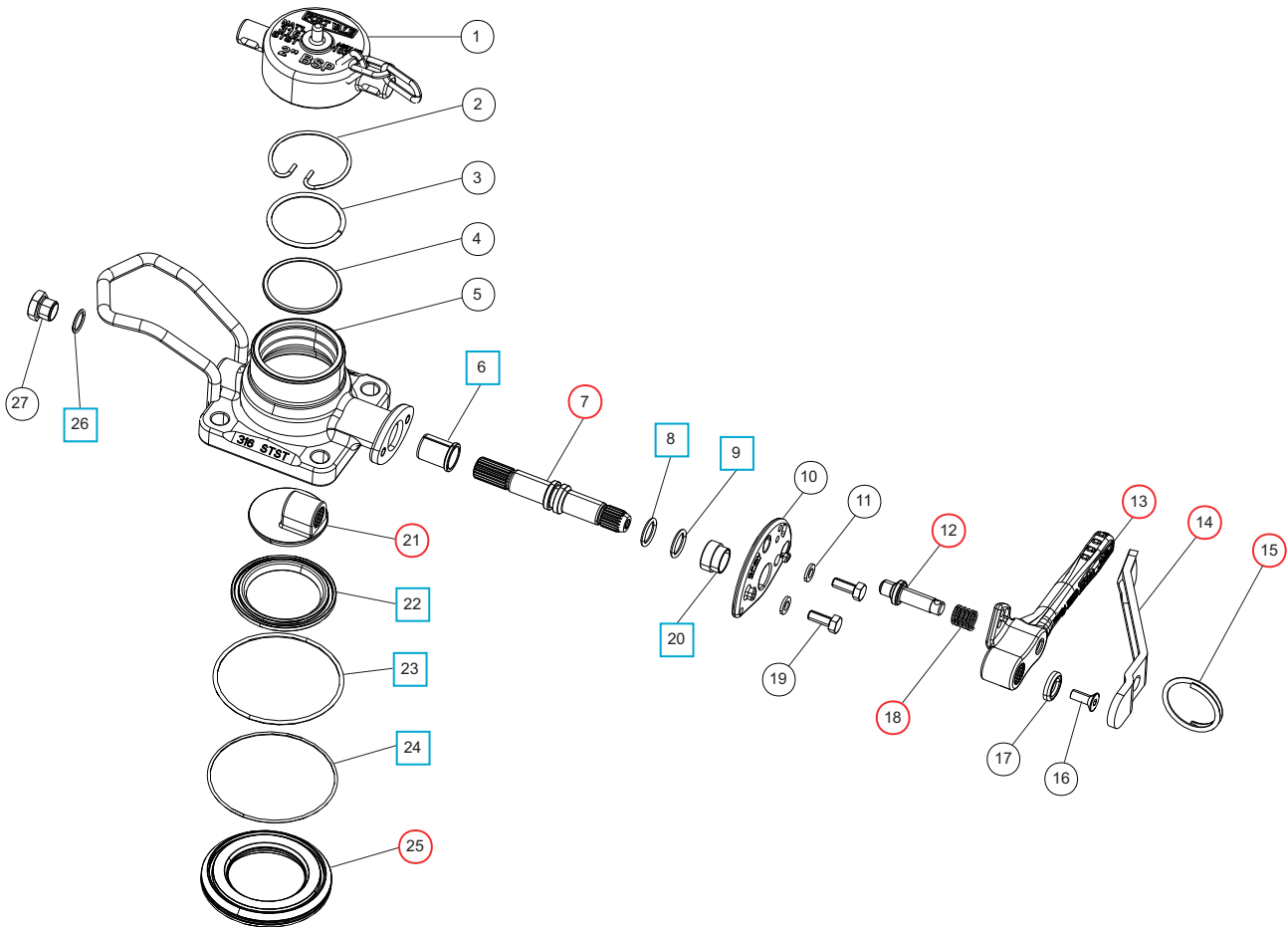

Parts List

Item	Description	Part No.
1	2" BSP dust cap (supplied separately)	10301PS
2	Snap ring * Note 1 & 2	5120-005
3	Spacer * Note 1 & 2	355/0295
4	Gauze filter * Note 1 Sintered filter (2) * Note 2	355/0010 355/0206
5	Body	535/0215
6	PTFE bush	535/0009 <input type="checkbox"/> <input type="radio"/>
7	Spindle	535/0203 <input type="radio"/>
8	Viton O ring	20361 <input type="checkbox"/> <input type="radio"/>
9	PTFE O ring	20363 <input type="checkbox"/> <input type="radio"/>
10	Stuffing clamp	535/0204
11	Spring washer (2)	5113-008
12	Handle location pin	368/0010 <input type="radio"/>
13	Handle	535/0050 <input type="radio"/>
14	Operating lever	368/9838 <input type="radio"/>
15	Split ring	368/0011 <input type="radio"/>
16	Countersunk bolt	5111-030
17	Retaining washer	20370
18	Handle spring	368/0012 <input type="radio"/>

Parts List

Item	Description	Part No.
19	Hex bolt (2)	5111-022
20	PTFE stuffing clamp bush	368/0301 <input type="checkbox"/> <input type="radio"/>
21	Closure plate	535/0225 <input type="radio"/>
22	PTFE main seal	355/0202 <input type="checkbox"/> <input type="radio"/>
23	PTFE O ring	5005-659 <input type="checkbox"/> <input type="radio"/>
24	EPDM O ring	5005-664 <input type="checkbox"/> <input type="radio"/>
25	Clamp plate	535/0201 <input type="radio"/>
26	PTFE O ring	5005-048 <input type="checkbox"/> <input type="radio"/>
27	1/4" BSP plug	5128-005

NOTE 1: Optional part, see Range 535/0200F

NOTE 2: Optional part, see Range 535/0200S

Seal Kit

Description	Part No.
All parts marked <input type="checkbox"/> in the Parts List	535/00SK

Repair Kit

Description	Part No.
All parts marked <input type="radio"/> in the Parts List	535/00RK



2" MKII Flanged Airline Butterfly Valve

Part No: 535/3000

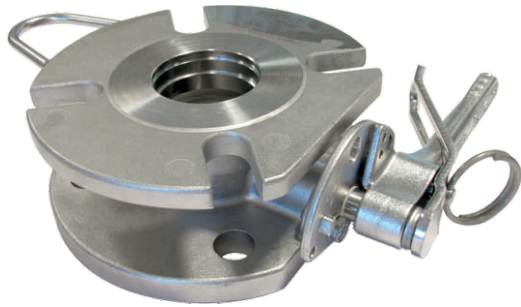

Specification

Nominal size

50mm

Tank connection

Flanged: 4 x 18mm holes on a 125mm PCD (DIN50 PN10)

Outlet/Process connection

Flanged: 4 x open slots, min. PCD: 2" BSTD

Properties

1/4" BSP gauge connection, gauge guard, handle with TIR

Materials

Contact parts: 316 stainless steel

Main seal: PTFE

Alternatives are available, refer to the Design Options page

Design Conditions

Weight:	5.9 Kg
Design Pressure (MAWP):	6.9 Bar
Test Pressure:	12.6 Bar
Design Temperature Min:	-40°C
Design Temperature Max:	190°C

NOTE: The Design Conditions and Section View dimensions are for the specified part number only.

Design Code

BS EN14432

Range

Description	Part No.
Standard specification	535/3000
With gauze filter	535/3000F
With sintered filter	535/3000S
With TIR wire to 1/4" BSP plug	535/3000W

Related Parts

Description	Part No.
Blind flange	370/4239CM
Inlet gasket	5005-360
Pressure gauge	920/07BBSP
Gauge adaptor	352/4004
Stud kit	311/3700
Outlet gasket	5005-361
Weld-in flange	355/3100

Section View

GAUZE FILTER WITH SNAP RING & SPACER (SUFFIX F)

SINTERED FILTERS WITH SNAP RING & SPACER (SUFFIX S)

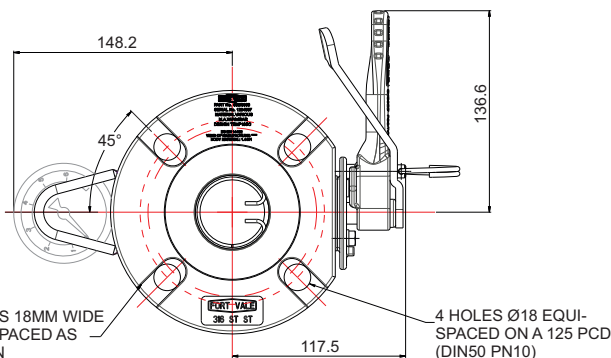
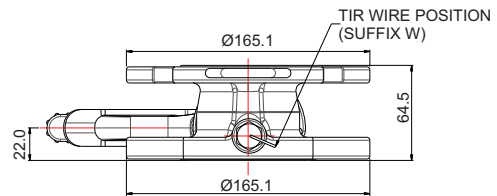
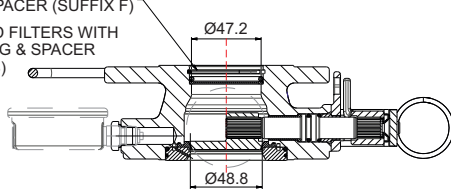



2" MKII Flanged Airline Butterfly Valve

Part No: 535/3000

Parts Drawing

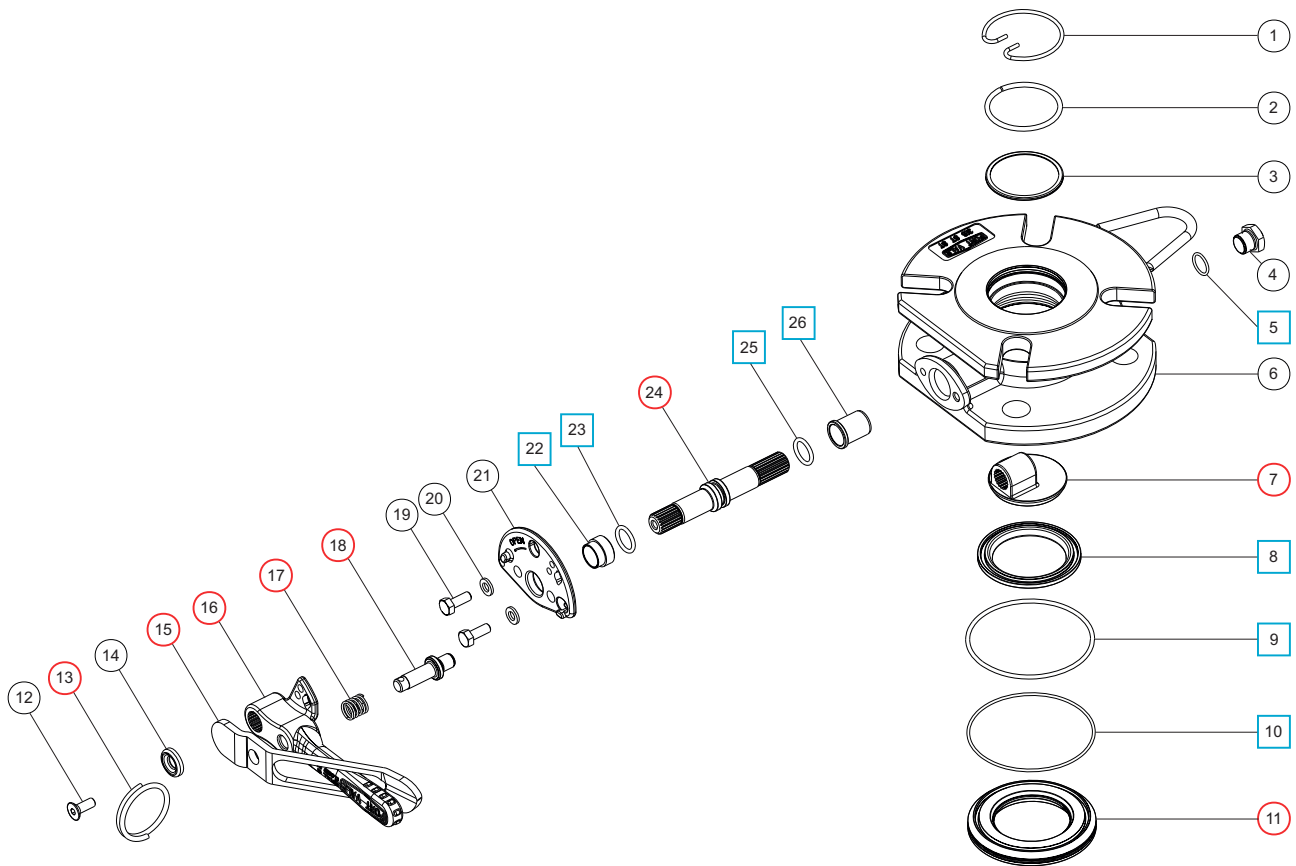

Parts List

Item	Description	Part No.
1	Snap ring * Note 1 & 2	5120-005
2	Spacer * Note 1 & 2	355/0295
3	Gauze filter * Note 1	355/0010
	Sintered filter (2) * Note 2	355/0206
4	1/4" BSP plug	5128-005
5	PTFE O ring	5005-048 <input type="checkbox"/> <input type="radio"/>
6	Body	535/3015
7	Closure plate	535/0225 <input type="radio"/>
8	Main seal	355/0202 <input type="checkbox"/> <input type="radio"/>
9	PTFE O ring	5005-659 <input type="checkbox"/> <input type="radio"/>
10	EPDM O ring	5005-664 <input type="checkbox"/> <input type="radio"/>
11	Seal plate	535/0201 <input type="radio"/>
12	M6 screw	5111-030
13	Split ring	368/0011 <input type="radio"/>
14	Retaining washer	20370
15	Operating lever	368/9838 <input type="radio"/>
16	Handle	535/0050 <input type="radio"/>
17	Handle spring	368/0012 <input type="radio"/>
18	Location pin	368/0010 <input type="radio"/>
19	M6 hex bolt (2)	5111-022

Parts List

Item	Description	Part No.
20	M6 spring washer (2)	5113-008
21	Stuffing clamp	535/0204C
22	Stuffing bush	368/0301 <input type="checkbox"/> <input type="radio"/>
23	PTFE O ring	20363 <input type="checkbox"/> <input type="radio"/>
24	Spindle	535/0203 <input type="radio"/>
25	Viton O ring	20361 <input type="checkbox"/> <input type="radio"/>
26	PTFE bearing	535/0009 <input type="checkbox"/> <input type="radio"/>

NOTE 1: Optional part, see Range 535/3000F

NOTE 2: Optional part, see Range 535/3000S

Seal Kit

Description	Part No.
All parts marked <input type="checkbox"/> in the Parts List	535/00SK

Repair Kit

Description	Part No.
All parts marked <input type="radio"/> in the Parts List	535/00RK



Pressure Gauges

Accessories & Spare Parts

Standard Pressure Gauge



Tell-Tale Pressure Gauge



Specification

We supply standard pressure gauges and tell-tale pressure gauges. Tell-tale pressure gauges have a secondary pointer to indicate if there has been an increase in pressure, even if the pressure subsequently decreases.

All pressure gauges have a 1/4" BSP bottom connection and are glycerine filled.

Pressure range options

0-6 Bar, 0-10 Bar, 0-16 Bar, 0-40 Bar

Material options - internal parts

Brass, stainless steel

Standard Pressure Gauge

Pressure Range Bar	Pressure Range PSI	Internal Parts	Part No.
0-6	0-90	Brass	921/06BBSP
0-6	0-90	St/steel	920/06BBSP
0-10	0-150	Brass	921/10BBSP
0-10	0-150	St/steel	920/10BBSP
0-40	0-580	St/steel	920/40BBSP

Tell-Tale Pressure Gauge

Pressure Range Bar	Pressure Range PSI	Internal Parts	Part No.
0-6	0-90	Brass	921/06TTBBSP
0-6	0-90	St/steel	920/06TTBBSP
0-10	0-150	Brass	921/10TTBBSP
0-10	0-150	St/steel	920/10TTBBSP
0-16	0-230	St/steel	920/16TTBBSP
0-40	0-580	St/steel	920/40TTBBSP



Weld-In Flanges for Airline Valves

Accessories & Spare Parts

Part No: 350/0025



Section View

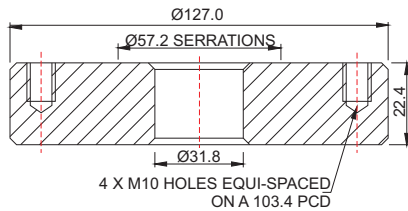

Specification

Flange type

Weld-in flange

Nominal size

32mm

Flange drilling

4 x M10 holes equi-spaced on a 103.4mm PCD

Material

316L stainless steel

Compatible valve

1½" airline ball valve

Related Parts

Description	Part No.
Stud kit	350/1300

Part No: 355/1000



Section View

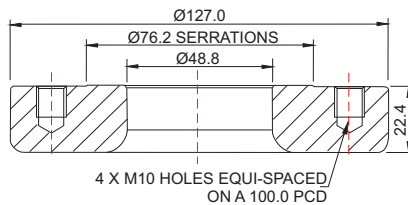

Specification

Flange type

Weld-in flange

Nominal size

50mm

Flange drilling

4 x M10 holes equi-spaced on a 100.0mm PCD

Material

316L stainless steel

Compatible valve

2" BSP airline butterfly valve

Related Parts

Description	Part No.
Stud kit	350/1300

Part No: 355/3100



Section View

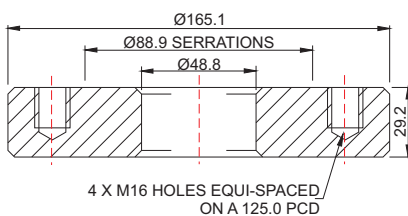

Specification

Flange type

Weld-in flange

Nominal size

50mm

Flange drilling

4 x M16 holes equi-spaced on a 125.0mm PCD

Material

316L stainless steel

Compatible valve

2" flanged butterfly valve

2" flanged ball valve

Related Parts

Description	Part No.
Stud kit	311/3700



Airline Ball Valves & Airline Butterfly Valves

Installation Options

1½" Airline Ball Valves

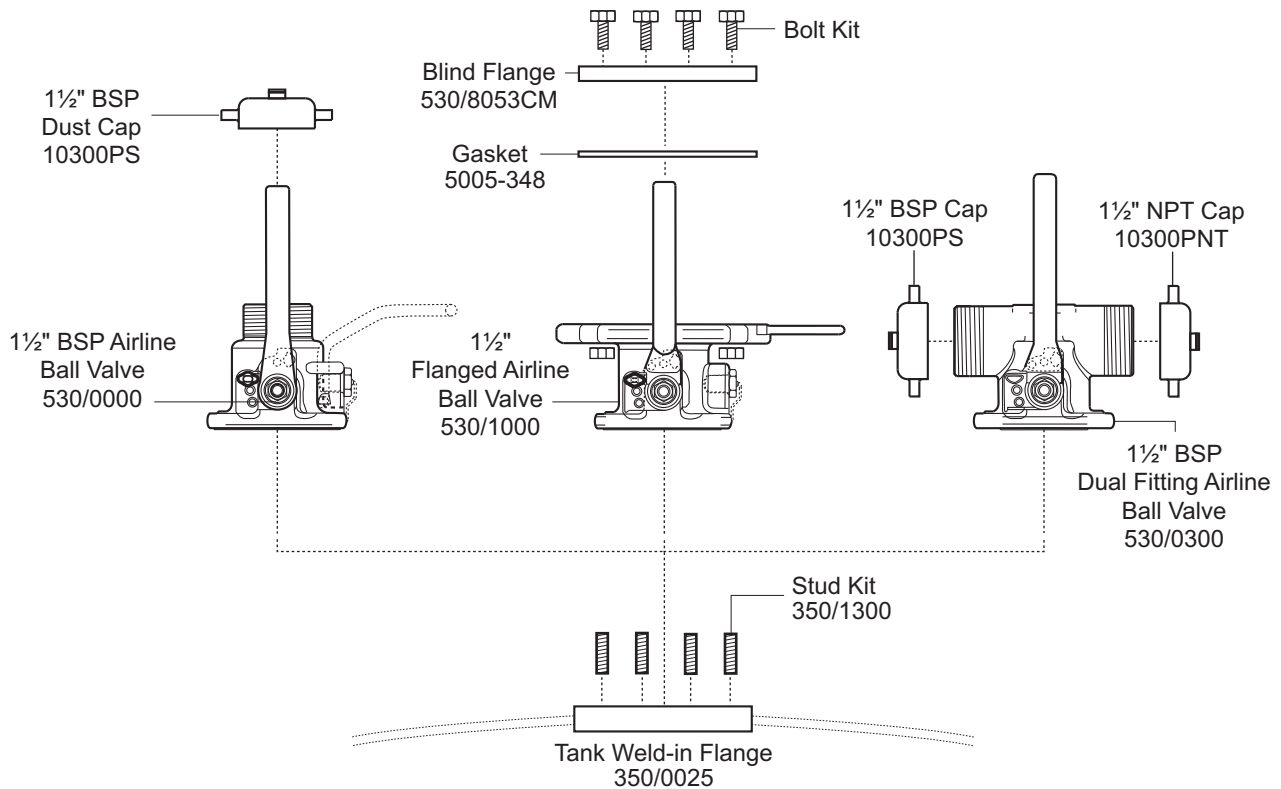

2" Airline Butterfly Valves

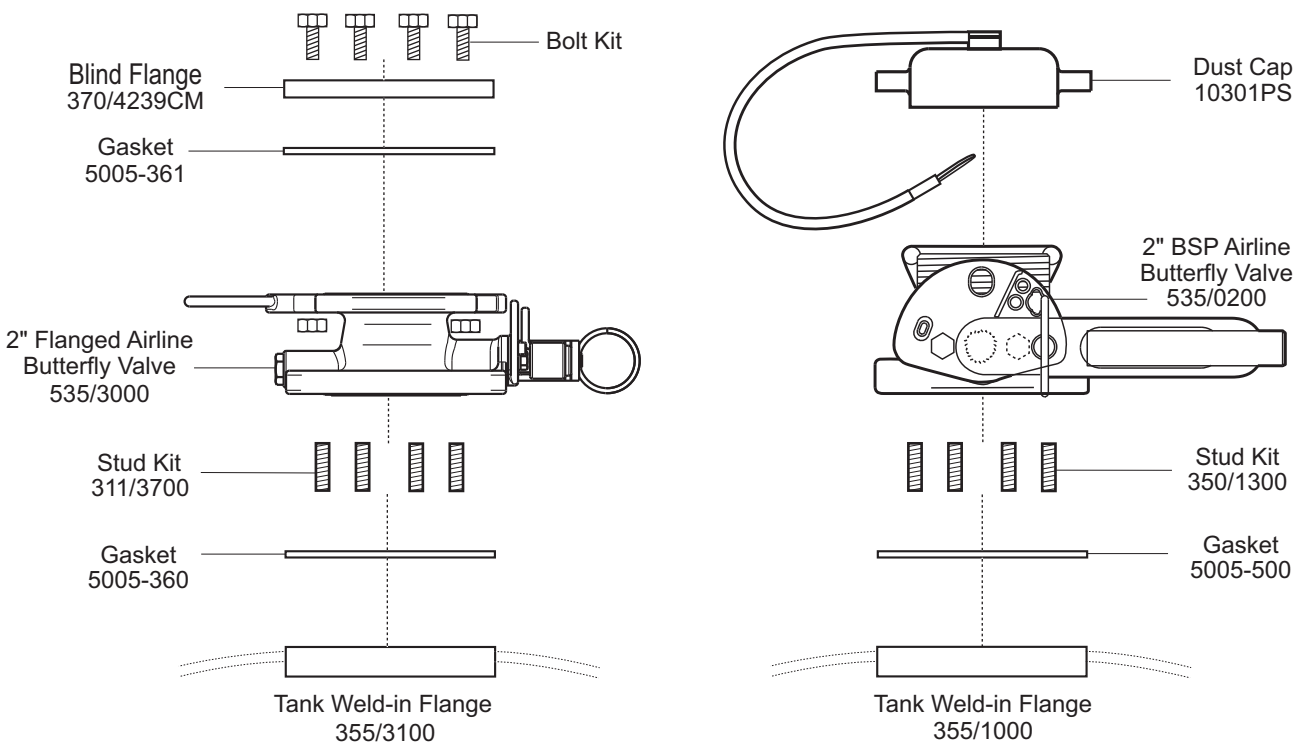

THIS PAGE IS INTENTIONALLY BLANK



Discharge Butterfly Valves

Design Options

Function

A discharge butterfly valve is used to load and discharge cargo. It is usually a secondary closure valve that is installed onto a footvalve (primary closure valve) at the drain point of a tank. A butterfly valve can also be used as a primary closure valve on the top of a tank.

NOTE: Refer to a separate page for discharge butterfly valves dedicated to Road Tankers.

Design Options

The design options below are available on our standard range of discharge butterfly valves.

Clamped Body

Scrolled face, installed between two flanges



Flanged Body

4 or 6 hole drilling patterns
Dual-drilled hole patterns
Open slots



TW Drilled Body

Compatible with Tankwagen drilling pattern



Nominal Bore

50mm (2")
80mm (3")
100mm (4")

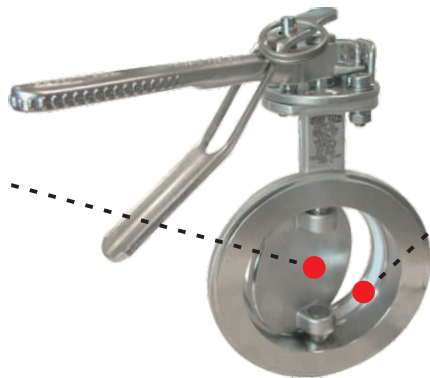

Main Seal

PTFE

Special service conditions:

High-temperature compatible seals

Operation

Manually operated
Lockable handle
Left hand or right hand operation
Pneumatically actuated





Discharge Butterfly Valves Design Options

Design Options - continued

Valve Materials

316 stainless steel

Special service applications:

Lined wetted parts, e.g. PFA

Wetted parts in high nickel alloys,
e.g. 904L stainless steel, Alloy C276



Special Cargoes

Solidifying cargo:

Body with steam-heating connections

Hemispherical closure plate



Related Parts

We recommend our range of compatible accessories:

- Flanges - inlet, adapter, outlet, blind
- Tertiary closures
- Fasteners
- Gaskets

Please contact us for more information about these parts.

Discharge Butterfly Valves for Dedicated Service

We offer a range of discharge butterfly valves suitable for these service conditions and special cargoes:

- Road Tankers
- Hygienic service

Please contact us for more information about these valves.



2" Clamped Widdop Butterfly Valve

Part No: 355/7000



Specification

Nominal size

50mm

Body type

Clamped

Properties

Left hand operated, handle with TIR and padlock slots

Materials

Contact parts: 316 stainless steel

Main seal: PTFE

Alternatives are available, refer to the Design Options page

Design Conditions

Weight:	2.2 Kg
Design Pressure (MAWP):	6 Bar
Test Pressure:	10 Bar
Design Temperature Min:	-40°C
Design Temperature Max:	200°C

NOTE: The Design Conditions and Section View dimensions are for the specified part number only.

Design Code

BS EN 14432

Related Parts

Description	Part No.
CNAF/PTFE inlet gasket *Note	5005-724
CNAF/PTFE outlet gasket *Note	6005-610

NOTE: Gasket drilling 4 x 18mm holes on a 125mm PCD

Section View

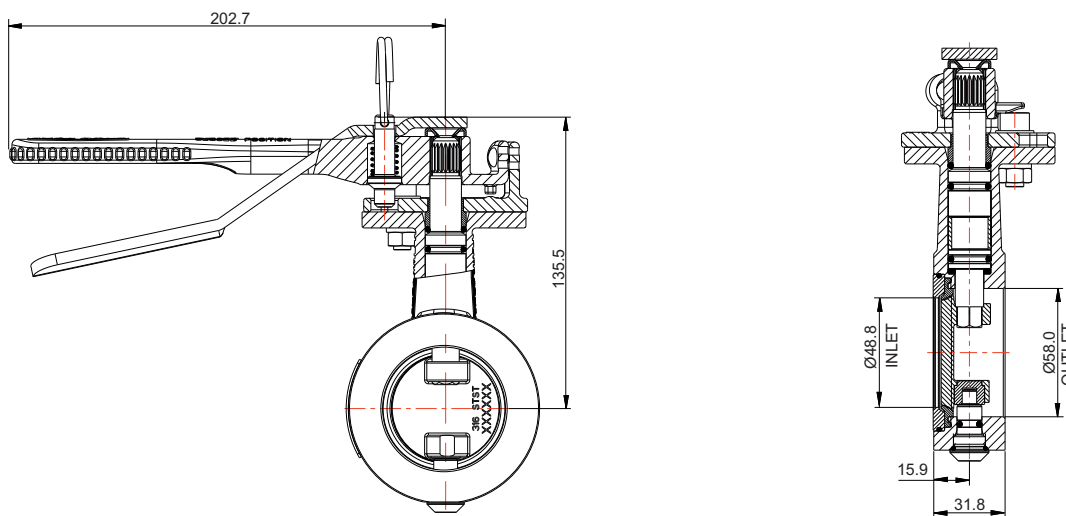



2" Clamped Widdop Butterfly Valve

Part No: 355/7000

Parts Drawing

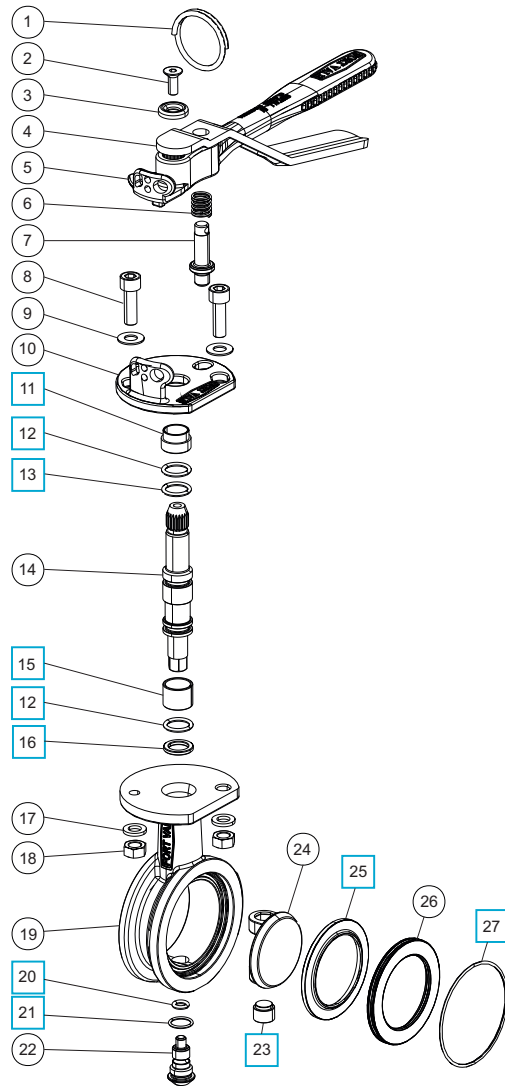

Parts List

Item	Description	Part No.	
1	Split ring	368/0011	
2	M6 countersunk bolt	5111-030	
3	Washer	20370	
4	Operating lever	368/9837	
5	Handle	368/0050	
6	Handle location spring	368/0012	
7	Handle location pin	368/0010	
8	Sockethead capscrew (2)	5111-148	
9	Plain washer (2)	5113-005	
10	Stuffing clamp	368/0040	
11	PTFE stuffing clamp bush	368/0301	<input type="checkbox"/>
12	PTFE O ring (2)	20363	<input type="checkbox"/>
13	Viton O ring	20361	<input type="checkbox"/>
14	Spindle	355/5020	
15	Split bearing	252/0517	<input type="checkbox"/>
16	PTFE spindle seat	355/5009	<input type="checkbox"/>
17	Spring washer (2)	5113-003	
18	Full nut (2)	5112-001	
19	Body	355/7010	
20	PTFE O ring	5005-541	<input type="checkbox"/>
21	PTFE O ring	5005-048	<input type="checkbox"/>
22	Bottom spindle	355/5005	
23	PTFE lower bush	355/5007	<input type="checkbox"/>
24	Closure plate	355/5030	
25	PTFE main seal	355/0202	<input type="checkbox"/>
26	Seal clamp plate	355/0201	
27	EPDM O ring	5005-476	<input type="checkbox"/>

Seal Kit

Description	Part No.
All parts marked <input type="checkbox"/> in the Parts List	355/70SK



3" Clamped Widdop Butterfly Valve

Part No: 368/7000B



Specification

Nominal size

80mm

Body type

Clamped

Properties

Left hand operated, handle with TIR and padlock slots

Materials

Contact parts: 316 stainless steel

Main seal: PTFE

Alternatives are available, refer to the Design Options page

Design Conditions

Weight:	3.5 Kg
Design Pressure (MAWP):	6 Bar
Test Pressure:	10.2 Bar
Design Temperature Min:	-40°C
Design Temperature Max:	200°C

NOTE: The Design Conditions and Section View dimensions are for the specified part number only.

Design Code

BS EN14432

Design Approvals

Lloyds Register of Shipping
Rijksdienst
SNCF
RMRS

Range

Description	Part No.
Standard specification	368/7000B
With hemi-spherical closure plate	368/9110B
Std. specification, right hand operated	368/4000A

Related Parts

Description	Part No.
CNAF/PTFE inlet gasket	5005-049
CNAF/PTFE outlet gasket	5005-490
CNAF/PTFE 4 hole square inlet gasket	5005-198
CNAF/PTFE 4 hole square outlet gasket	5005-195
Bolting kit	368/1100
3" BSP outlet flange	SP368/8047
3" BSP blank cap with PTFE seal	10303PS
3" camlock outlet flange	368/8058
3" camlock blank cap	90/DC300
DIN80 mating flange	294/0081

Section View

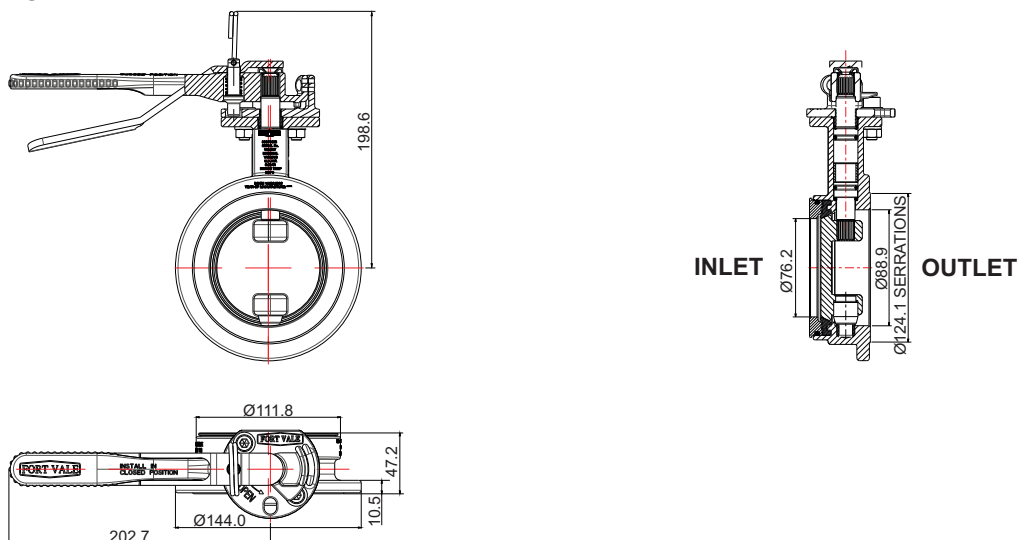



3" Clamped Widdop Butterfly Valve

Part No: 368/7000B

Parts Drawing

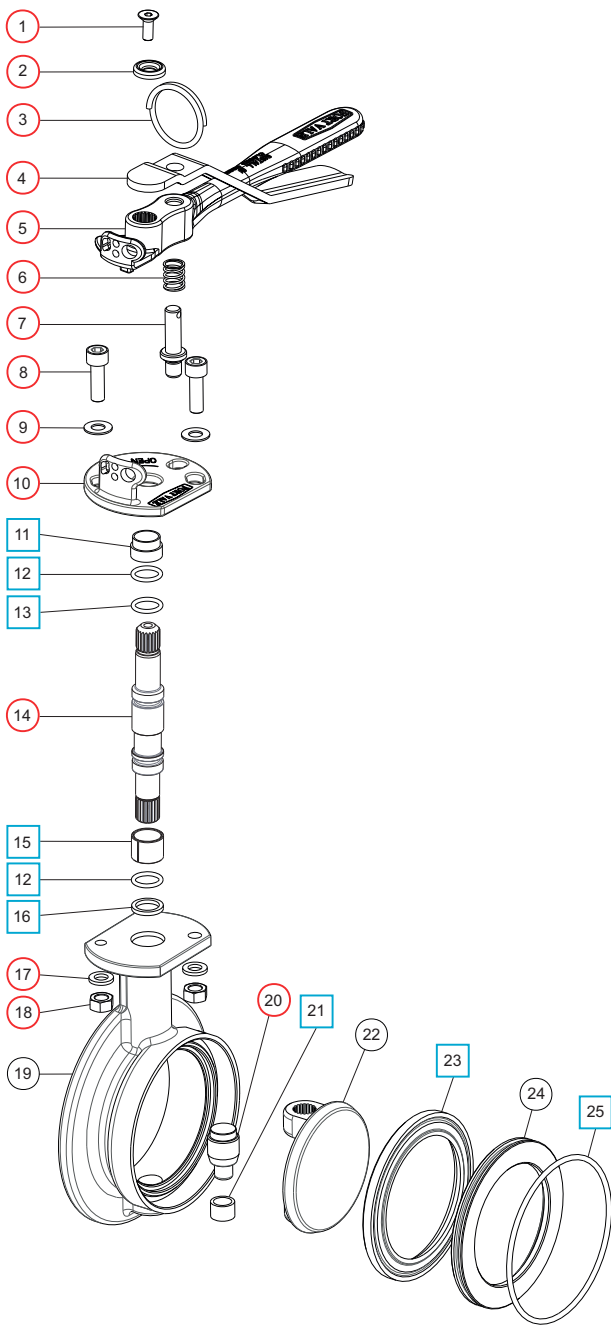

Parts List

Item	Description	Part No.	
1	M6 set screw	5111-030	○
2	Washer	20370	○
3	Split ring	368/0011	○
4	Operating lever	368/9837	○
5	Handle	368/0050	○
6	Handle location spring	368/0012	○
7	Handle location pin	368/0010	○
8	M8 cap screw (2)	5111-148	○
9	M8 plain washer (2)	5113-005	○
10	Stuffing clamp	368/0040	○
11	PTFE stuffing clamp bush	368/0301	□ ○
12	PTFE O ring (2)	20363	□ ○
13	Viton O ring	20361	□ ○
14	Spindle *Note	368/0200	○
15	Split bearing	252/0517	□ ○
16	PTFE spindle seat	368/0009	□ ○
17	M8 spring washer (2)	5113-003	○
18	M8 full nut (2)	5112-001	○
19	Body	368/0150	
20	Bottom spindle	368/0036	○
21	PTFE bottom bush	368/0035	□ ○
22	Closure plate	368/0400	
23	PTFE main seal	368/0002	□ ○
24	Seal clamp plate	368/0045	
25	Nitrile O ring	5005-342	□ ○

NOTE: We can supply the spindle with the seals installed. Part no. **368/0200S** includes item 11 thru 16.

Seal Kit

Description	Part No.
All parts marked □ in the Parts List	368/00SK

Repair Kit

Description	Part No.
All parts marked ○ in the Parts List, includes 368/0200S (see NOTE)	368/00RKA



3" Clamped Widdop Butterfly Valve - High Temperature

Part No: 368/71HTB



Specification

Nominal size

80mm

Body type

Clamped

Properties

Left hand operated, handle with TIR and padlock slots

Materials

Contact parts: 316 stainless steel

Main seal: Flexityt

Alternatives are available, refer to the Design Options page

Design Conditions

Weight:	3.7 Kg
Design Pressure (MAWP):	6.9 Bar
Test Pressure:	10.35 Bar
Design Temperature Min:	-40°C
Design Temperature Max:	260°C *Note

NOTE: The maximum design temperature may be decreased by the maximum working temperature of the inlet/outlet gaskets. Design Conditions and Section View dimensions are for the specified part number only.

Design Code

BS EN14432

Design Approvals

Lloyds Register of Shipping
Rijksdienst
SNCF
RMRS

Range

Description	Part No.
Standard specification	368/71HTB
With hemi-spherical closure plate	368/91HTB

Related Parts

Description	Part No.
CNAF/PTFE inlet gasket	5005-049HT
CNAF/PTFE outlet gasket	5005-490HT
CNAF/PTFE 4 hole square inlet gasket	5005-198HT
CNAF/PTFE 4 hole square outlet gasket	5005-195HT
Bolting kit	368/1100
3" BSP outlet flange	368/8047
3" BSP blank cap with PTFE seal	10303PS
3" camlock outlet flange	368/8058
3" camlock blank cap	90/DC300
3" NPT outlet flange	368/8049
3" NPT blank cap with PTFE washer	425/3250

Section View

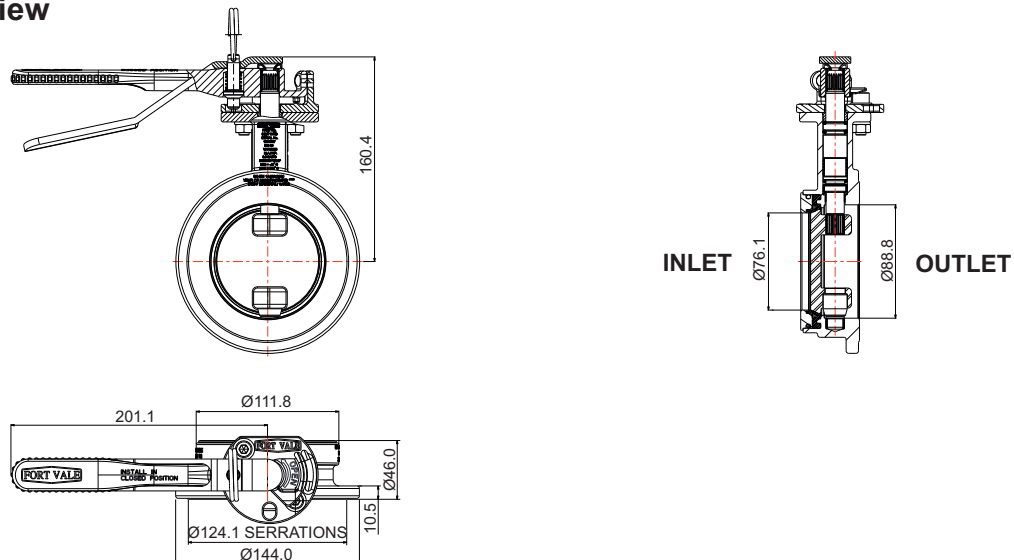



3" Clamped Widdop Butterfly Valve - High Temperature

Part No: 368/71HTB

Parts Drawing

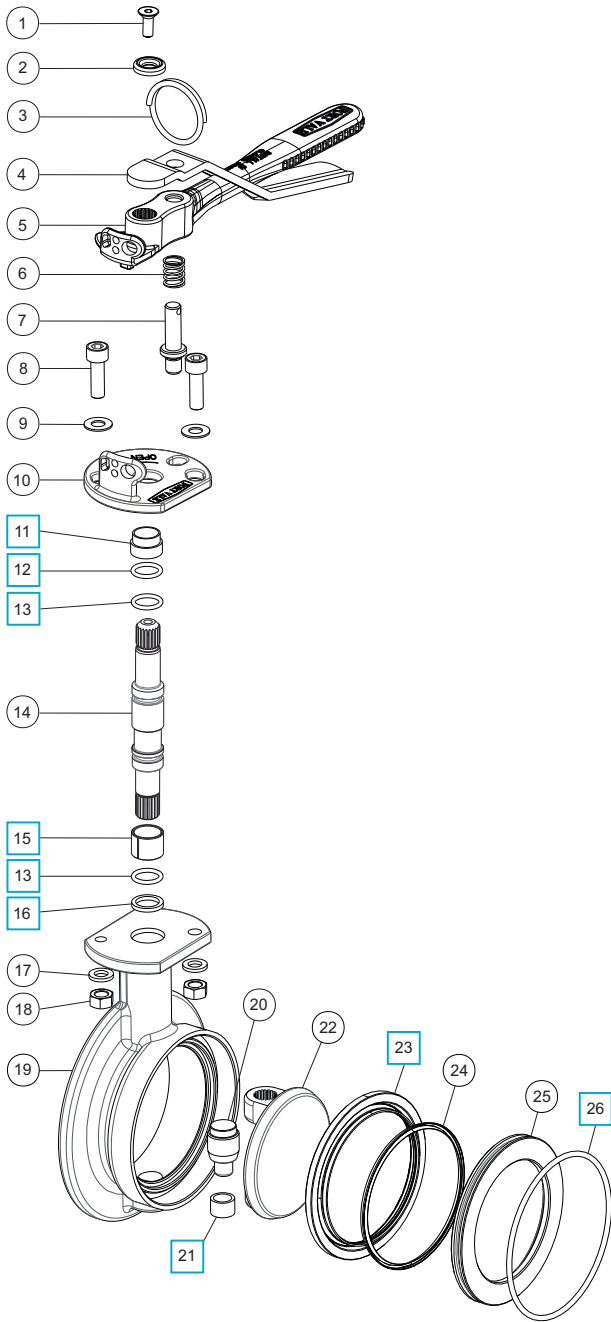

Parts List

Item	Description	Part No.	
1	M6 set screw	5111-030	
2	Washer	20370	
3	Split ring	368/0011	
4	Operating lever	368/9837	
5	Handle	368/0050	
6	Handle location spring	368/0012	
7	Handle location pin	368/0010	
8	M8 cap screw (2)	5111-148	
9	M8 plain washer (2)	5113-005	
10	Stuffing clamp	368/0040	
11	PTFE stuffing clamp bush	368/0301	<input type="checkbox"/>
12	RTFE O ring	20363HT	<input type="checkbox"/>
13	Perfluoroelastomer O ring (2)	5005-586	<input type="checkbox"/>
14	Spindle	368/0205	
15	RTFE spindle bearing	368/0039	<input type="checkbox"/>
16	RTFE spindle seat	368/0009HT/1	<input type="checkbox"/>
17	M8 spring washer (2)	5113-003	
18	M8 full nut (2)	5112-001	
19	Body	368/0150	
20	Bottom spindle	368/0038	
21	RTFE bottom bush	368/0037	<input type="checkbox"/>
22	Closure plate	368/0400	
23	RTFE main seal	368/0002HT/5	<input type="checkbox"/>
24	Seal spring	368/0031	
25	Seal clamp plate	368/0033	
26	Silicone O ring	5005-342S	<input type="checkbox"/>

Seal Kit

Description	Part No.
All parts marked <input type="checkbox"/> in the Parts List	368/71SKB



3" Clamped Widdop Butterfly Valve - Pneumatically Actuated

Part No: 368/7000BPN



Specification

Nominal size

80mm

Body type

Clamped

Properties

With spring-return pneumatic actuator and anti-clockwise opening

Materials

Contact parts: 316 stainless steel

Main seal: PTFE

Alternatives are available, refer to the Design Options page

Design Conditions

Valve Assembly Weight: 16.6 Kg

Butterfly Valve

Design Pressure (MAWP): 6 Bar
 Test Pressure: 10.5 Bar
 Design Temperature Min: -40°C
 Design Temperature Max: 200°C

Actuator

Actuator Maximum Pressure: 8 Bar
 Design Temperature Min: -20°C
 Design Temperature Max: 80°C

Actuator Operating Conditions

Start to open 3.1 Bar
 Fully open 3.8 Bar

NOTE: The Design Conditions and Section View dimensions are for the specified part number only.

Design Code

BS EN14432

Range

Description	Part No.
Std. specification - pneumatic actuator	368/7000BPN
Std. specification - manually operated	368/7000B

Related Parts

Description	Part No.
CNAF/PTFE inlet gasket	5005-049
CNAF/PTFE outlet gasket	5005-490
Bolting kit	368/1100
3" BSP outlet flange	368/8047
3" BSP blank cap with PTFE seal	10303PS

Section View

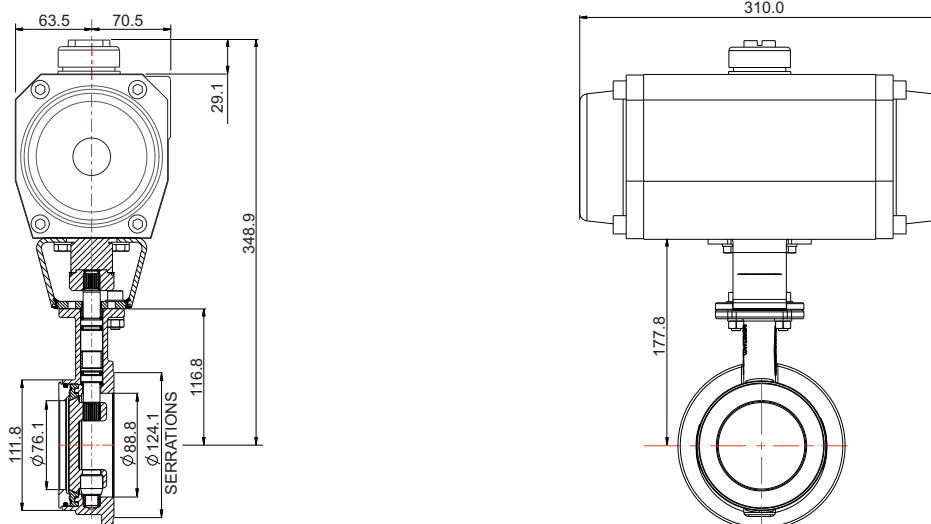



3" Clamped Widdop Butterfly Valve - Pneumatically Actuated

Part No: 368/7000BPN

Parts Drawing

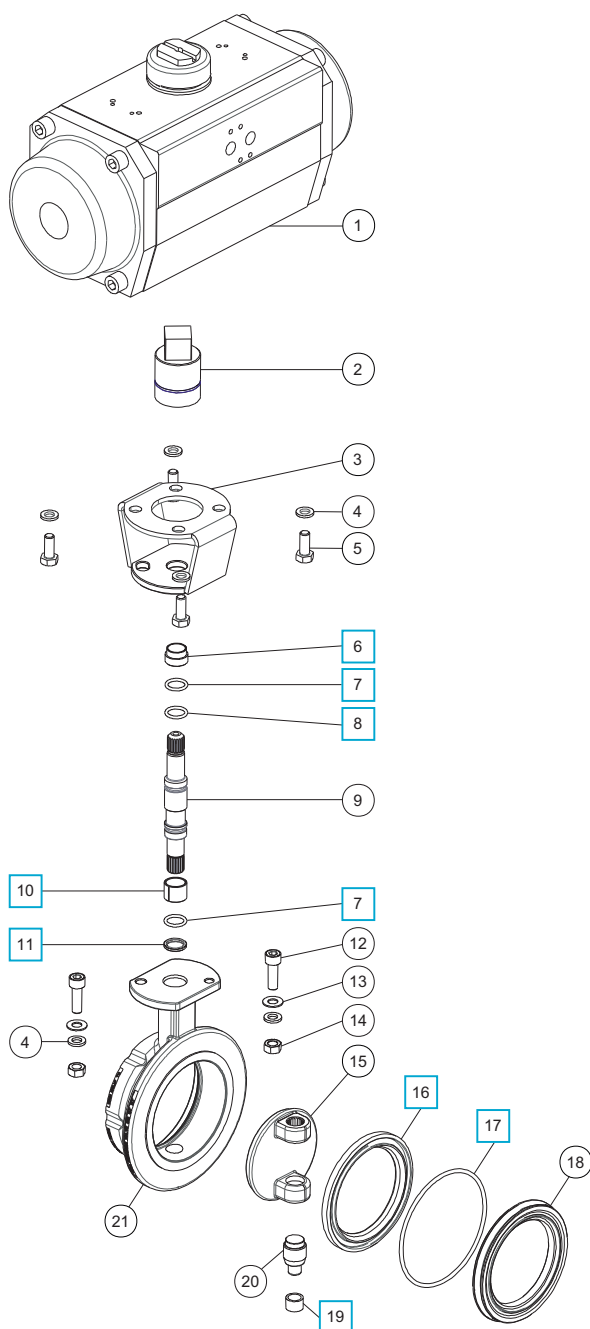

Parts List

Item	Description	Part No.	
1	Pneumatic actuator	5127-115	
2	Drive adaptor assembly	368/2824	
3	Bridge assembly	368/2820	
4	M8 flat spring washer (6)	5113-003	
5	M8 x 20mm bolt (4)	5111-822	
6	Stuffing clamp bush	368/0301	<input type="checkbox"/>
7	PTFE O ring (2)	20363	<input type="checkbox"/>
8	Viton O ring	20361	<input type="checkbox"/>
9	Spindle	368/0200/2	
10	Split bearing	252/0517	<input type="checkbox"/>
11	PTFE spindle seat	368/0009	<input type="checkbox"/>
12	M8 x 25mm cap screw (2)	5111-148	
13	M8 plain washer (2)	5113-005	
14	M8 full nut (2)	5112-001	
15	Closure plate	368/0400	
16	Main seal	368/0002	<input type="checkbox"/>
17	Nitrile O ring	5005-342	<input type="checkbox"/>
18	Seal clamp plate	368/0045	
19	Bottom bush	368/0035	<input type="checkbox"/>
20	Bottom spindle	368/0036	
21	Body	368/0150	

Seal Kit

Description	Part No.
All parts marked <input type="checkbox"/> in the Parts List	368/00SK



3" Clamped Widdop Butterfly Valve - Solidifying Cargo

Part No: 368/9110B



Specification

Nominal size

80mm

Body type

Clamped

Properties

Hemispherical closure plate

Left hand operated, handle with TIR and padlock slots

Materials

Contact parts: 316 stainless steel

Main seal: PTFE

Alternatives are available, refer to the Design Options page

Design Conditions

Weight:	4.0 Kg
Design Pressure (MAWP):	6 Bar
Test Pressure:	10 Bar
Design Temperature Min:	-40°C
Design Temperature Max:	200°C

NOTE: The Design Conditions and Section View dimensions are for the specified part number only.

Design Code

BS EN 14432

Design Approvals

Lloyds Register of Shipping

Rijksdienst

SNCF

RMRS

Range

Description	Part No.
With hemispherical closure plate	368/9110B
With standard closure plate	368/7000B

Related Parts

Description	Part No.
CNAF/PTFE inlet gasket	5005-049
CNAF/PTFE outlet gasket	5005-490
CNAF/PTFE 4 hole square inlet gasket	5005-198
CNAF/PTFE 4 hole square outlet gasket	5005-195
Bolting kit	368/1100
3" BSP outlet flange	368/8047
3" BSP blank cap with PTFE seal	10303PS
3" camlock outlet flange	368/8058
3" camlock blank cap	90/DC300
3" NPT outlet flange	368/8049
3" NPT blank cap with PTFE washer	425/3250

Section View

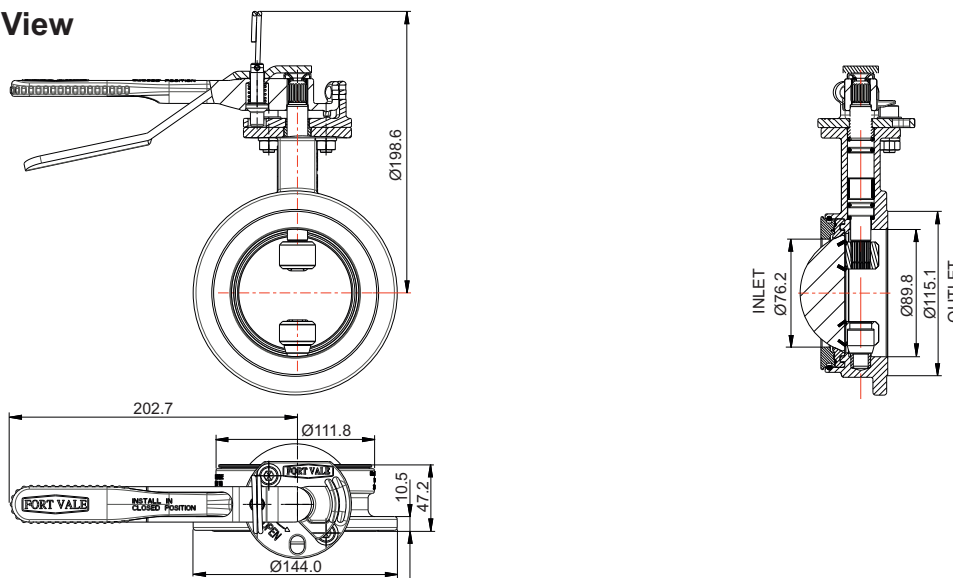



3" Clamped Widdop Butterfly Valve - Solidifying Cargo

Part No: 368/9110B

Parts Drawing

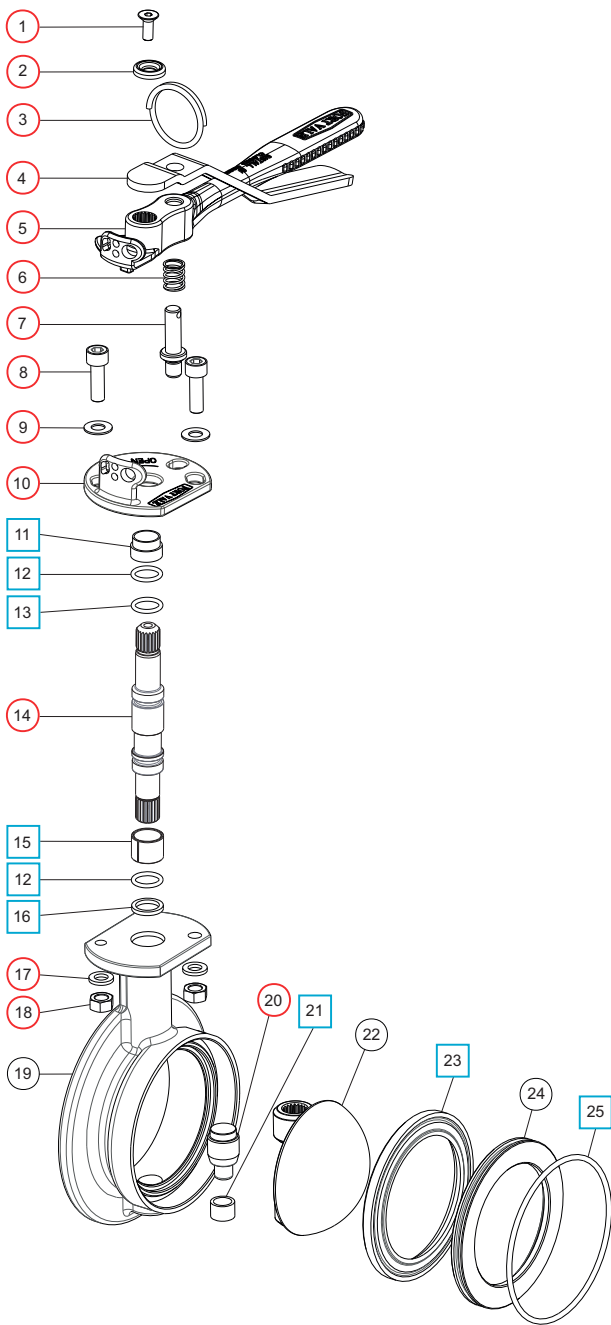

Parts List

Item	Description	Part No.	
1	M6 set screw	5111-030	○
2	Washer	20370	○
3	Split ring	368/0011	○
4	Operating lever	368/9837	○
5	Handle	368/0050	○
6	Handle location spring	368/0012	○
7	Handle location pin	368/0010	○
8	M8 cap screw (2)	5111-148	○
9	M8 plain washer (2)	5113-005	○
10	Stuffing clamp	368/0040	○
11	PTFE stuffing clamp bush	368/0301	□ ○
12	PTFE O ring (2)	20363	□ ○
13	Viton O ring	20361	□ ○
14	Spindle	368/0200	○
15	Split bearing	252/0517	□ ○
16	PTFE spindle seat	368/0009	□ ○
17	M8 spring washer (2)	5113-003	○
18	M8 full nut (2)	5112-001	○
19	Body	368/0150	
20	Bottom spindle	368/0036	○
21	PTFE bottom bush	368/0035	□ ○
22	Hemispherical closure plate	368/9101	
23	PTFE main seal	368/0002	□ ○
24	Seal clamp plate	368/0045	
25	Nitrile O ring	5005-342	□ ○

Seal Kit

Description	Part No.
All parts marked □ in the Parts List	368/00SK

Repair Kit

Description	Part No.
All parts marked ○ in the Parts List	368/00RKA



3" Flanged Widdop Butterfly Valve

Part No: 368/3160A

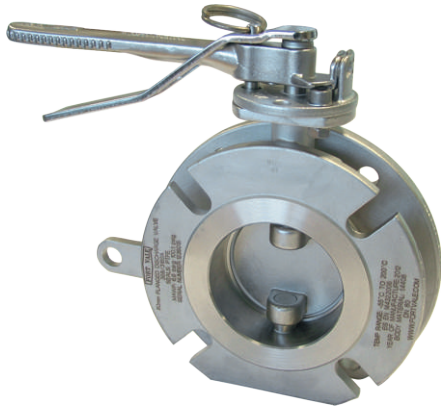

Specification

Nominal size

80mm

Tank connection

Flanged: 6 x 14mm holes on a 168mm PCD

Outlet/Process connection

Flanged: 4 x open slots on a 146mm minimum PCD

Properties

Left hand operated, handle with TIR and padlock slots

Materials

Contact parts: 316 stainless steel

Main seal: PTFE

Alternatives are available, refer to the Design Options page

Design Conditions

Weight:	7.0 Kg
Design Pressure (MAWP):	6.9 Bar
Test Pressure:	12.6 Bar
Design Temperature Min:	-55°C
Design Temperature Max:	200°C

NOTE: The Design Conditions and Section View dimensions are for the specified part number only.

Design Code

BS EN14432

Design Approvals

Lloyds Register of Shipping
Rijksdienst
SNCF
RMRS

Range

Description	Part No.
Standard specification	368/3160A
Inlet flange dual drilled: 4 hole/4 hole	368/3180A
Inlet flange dual drilled: 6 hole/4 hole	368/3280A

Related Parts

Description	Part No.
Tank weld-in flange	368/0800
CNAF/PTFE syphon tube inlet gasket	5005-222
Syphon tube	368/0810
Stud kit	312/1000
CNAF/PTFE inlet gasket	5005-169
Solid PTFE outlet gasket	5005-417
Dished blind flange	312/0022CM
Pivot pin for blind flange	368/7506

Section View

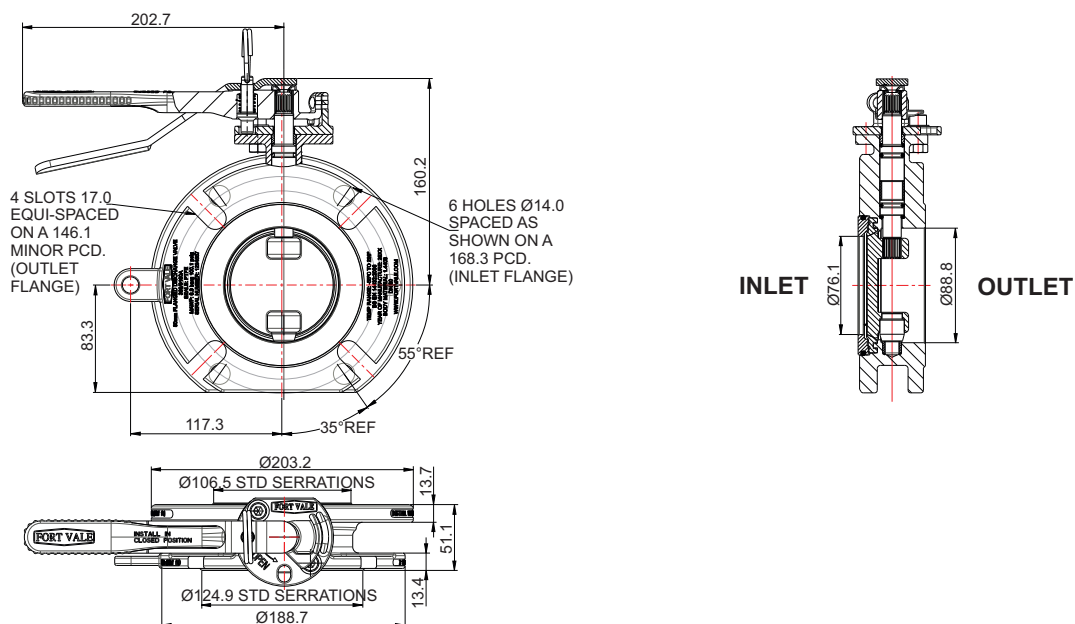



3" Flanged Widdop Butterfly Valve

Part No: 368/3160A

Parts Drawing

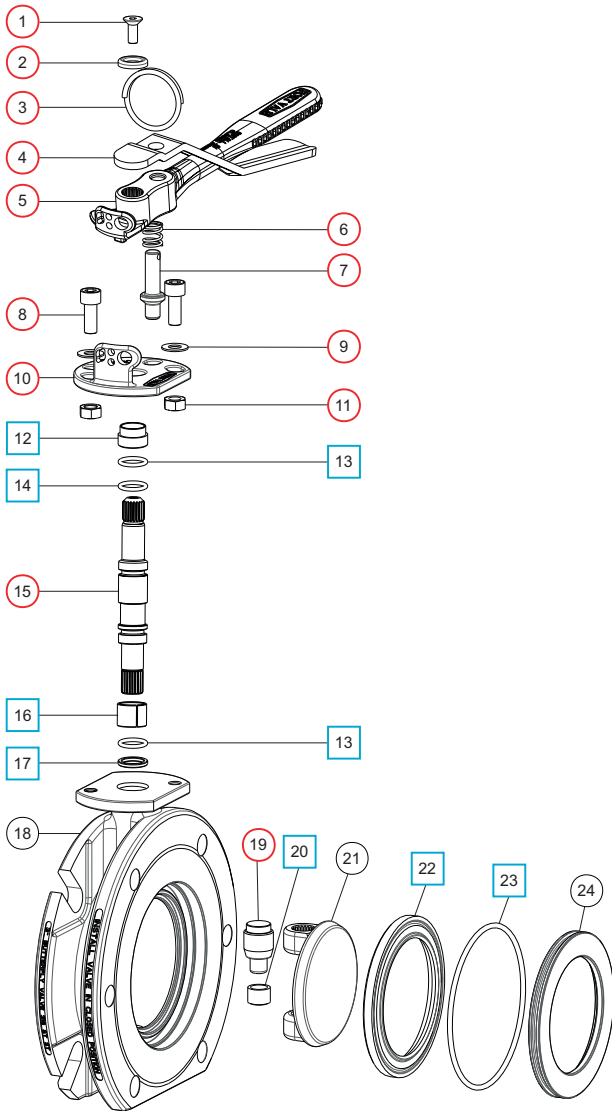

Parts List

Item	Description	Part No.	
1	M6 set screw	5111-030	○
2	Washer	20370	○
3	Split ring	368/0011	○
4	Operating lever	368/9837	○
5	Handle	368/0050	○
6	Handle location spring	368/0012	○
7	Handle location pin	368/0010	○
8	M8 cap screw (2)	5111-255	○
9	M8 plain washer (2)	5113-005	○
10	Stuffing clamp	368/0040	○
11	M8 full nut (2)	5112-001	○
12	PTFE stuffing clamp bush	368/0301	□ ○
13	PTFE O ring (2)	20363	□ ○
14	Viton O ring	20361	□ ○
15	Spindle	368/0200	○
16	Split bearing	252/0517	□ ○
17	PTFE spindle seat	368/0009	□ ○
18	Body	368/9141	
19	Bottom spindle	368/0036	○
20	PTFE bottom bush	368/0035	□ ○
21	Closure plate	368/0400	
22	PTFE main seal	368/0002	□ ○
23	Nitrile O ring	5005-342	□ ○
24	Seal clamp plate	368/9148	

Seal Kit

Description	Part No.
All parts marked □ in the Parts List	368/00SK

Repair Kit

Description	Part No.
All parts marked ○ in the Parts List	368/316RKA



3" Flanged Widdop Butterfly Valve - Dual Drilled Inlet

Part No: 368/3280A



Specification

Nominal size

80mm

Tank connection

Dual-drilled flange: 6 x 14mm holes on a 168.3mm PCD & 4 x 18mm holes on a 160mm PCD

Outlet/Process connection

Flanged: 4 x open slots on a 146mm minimum PCD

Properties

Left hand operated, handle with TIR and padlock slots

Materials

Contact parts: 316 stainless steel

Main seal: PTFE

Alternatives are available, refer to the Design Options page

Design Conditions

Weight:	6.9 Kg
Design Pressure (MAWP):	6.9 Bar
Test Pressure:	10.35 Bar
Design Temperature Min:	-40°C
Design Temperature Max:	200°C

NOTE: The Design Conditions and Section View dimensions are for the specified part number only.

Design Code

BS EN14432

Range

Description	Part No.
Inlet flange dual drilled: 6 hole/4 hole	368/3280A
Inlet flange dual drilled: 4 hole/4 hole	368/3180A
Inlet flange with flat, drilled 6 holes	368/3160A

Related Parts

Description	Part No.
CNAF/PTFE dual drilled inlet gasket	5005-770
CNAF/PTFE 6 hole inlet gasket	5005-222
CNAF/PTFE 4 hole inlet gasket	5005-034
Solid PTFE outlet gasket	5005-417
Dished blind flange	312/0022CM
Pivot pin for blind flange	368/7506

Section View

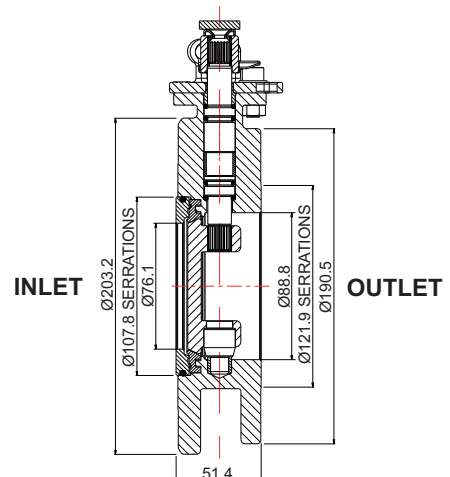
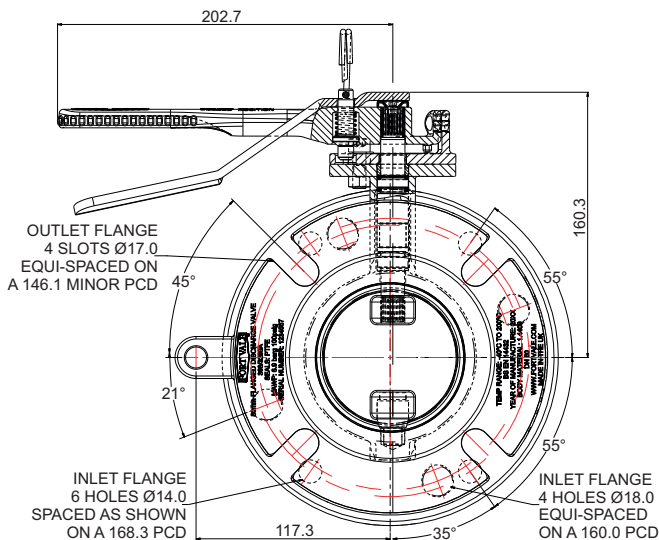



3" Flanged Widdop Butterfly Valve - Dual Drilled Inlet

Part No: 368/3280A

Parts Drawing

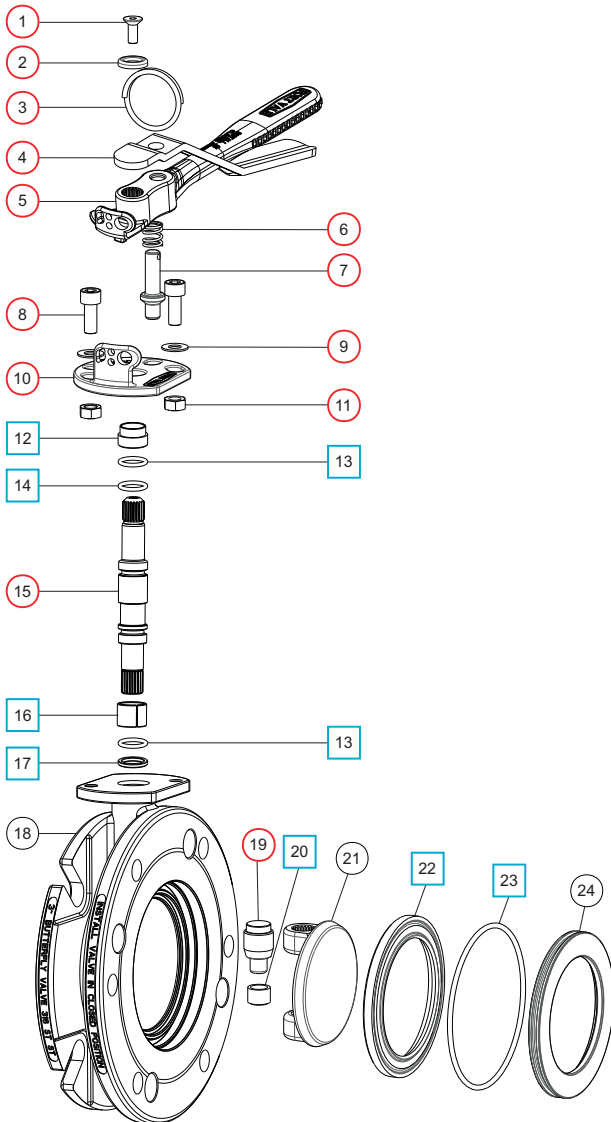

Parts List

Item	Description	Part No.	
1	M6 set screw	5111-030	○
2	Washer	20370	○
3	Split ring	368/0011	○
4	Operating lever	368/9837	○
5	Handle	368/0050	○
6	Handle location spring	368/0012	○
7	Handle location pin	368/0010	○
8	M8 cap screw (2)	5111-255	○
9	M8 plain washer (2)	5113-005	○
10	Stuffing clamp	368/0040	○
11	M8 full nut (2)	5112-001	○
12	PTFE stuffing clamp bush	368/0301	□ ○
13	PTFE O ring (2)	20363	□ ○
14	Viton O ring	20361	□ ○
15	Spindle	368/0200	○
16	Split bearing	252/0517	□ ○
17	PTFE spindle seat	368/0009	□ ○
18	Body	368/9192	
19	Bottom spindle	368/0036	○
20	PTFE bottom bush	368/0035	□ ○
21	Closure plate	368/0400	
22	PTFE main seal	368/0002	□ ○
23	Nitrile O ring	5005-342	□ ○
24	Seal clamp plate	368/9148	

Seal Kit

Description	Part No.
All parts marked □ in the Parts List	368/00SK

Repair Kit

Description	Part No.
All parts marked ○ in the Parts List	368/316RKA



TW80 Clamped Butterfly Valve

Part No: 368/5500B



Specification

Nominal size

80mm

Body type

Drilled 8 x 12mm holes on a 130mm PCD (TW80)

Properties

Left hand operated, lockable handle with TIR

Materials

Contact parts: 316 stainless steel

Main seal: PTFE

Alternatives are available, refer to the Design Options page

Design Conditions

Weight:	5.4 Kg
Design Pressure (MAWP):	6 Bar
Test Pressure:	10 Bar
Design Temperature Min:	-40°C
Design Temperature Max:	200°C

NOTE: The Design Conditions and Section View dimensions are for the specified part number only.

Design Code

BS EN14432

Design Approval

AIB Vincotte

Range

Description	Part No.
TW80 clamped valve	368/5500B
TW100 clamped valve	468/5600B

Related Parts

Description	Part No.
CNAF/PTFE TW80 gasket	5005-715
TW80 mating flange	845/8001
3" BSP eccentric TW80 outlet flange	368/5513

Section View

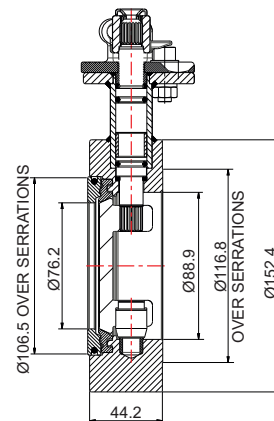
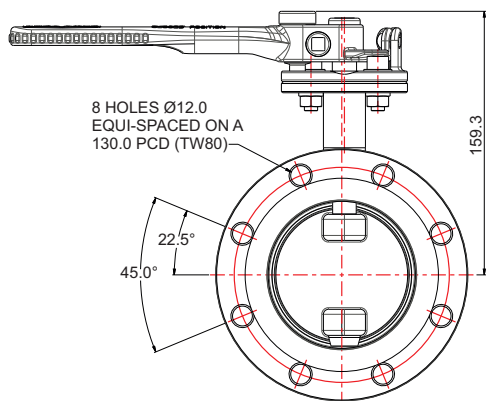



TW80 Clamped Butterfly Valve

Part No: 368/5500B

Parts Drawing

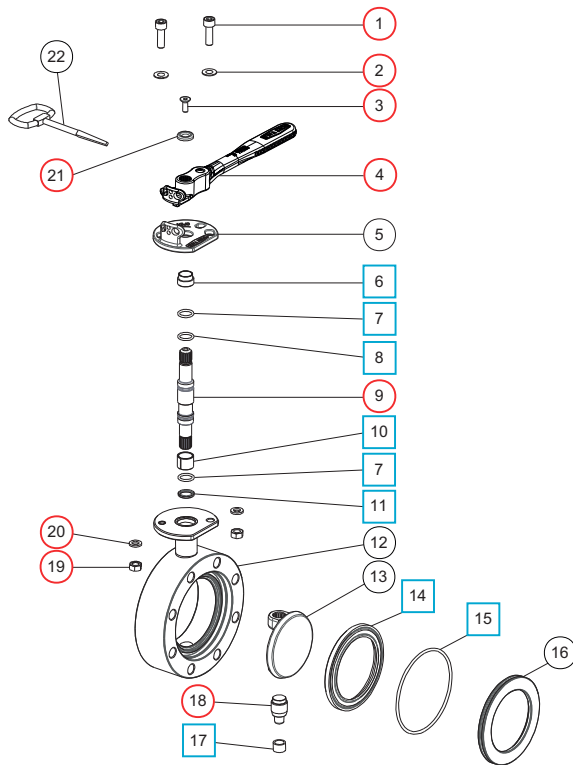

Parts List

Item	Description	Part No.	
1	M8 cap screw (2)	5111-148	○
2	M8 plain washer (2)	5113-005	○
3	M6 countersunk set screw	5111-030	○
4	Barrel lock handle	368/0075	○
5	Stuffing clamp	368/0041	
6	PTFE stuffing clamp bush	368/0301	□ ○
7	PTFE O ring (2)	20363	□ ○
8	Viton O ring	20361	□ ○
9	Spindle	368/0200	○
10	Split bearing	252/0517	□ ○
11	PTFE bearing	368/0009	□ ○
12	Body	368/5510	
13	Closure plate	368/0400	
14	Main seal	368/0002	□ ○
15	Nitrile O ring	5005-342	□ ○
16	Seal clamp	368/9148	
17	PTFE bottom bush	368/0035	□ ○
18	Bottom spindle	368/0036	○
19	M8 full nut (2)	5112-001	○
20	M8 spring washer (2)	5113-003	○
21	Retaining washer	20370	○
22	Key	368/4625	

Seal Kit

Description	Part No.
All parts marked □ in the Parts List	368/00SK

Repair Kit

Description	Part No.
All parts marked ○ in the Parts List	368/50RKB



4" Clamped Butterfly Valve

Part No: 468/7250B



Specification

Nominal size

100mm

Body type

Clamped

Properties

Left hand operated, handle with TIR and padlock slots

Materials

Contact parts: 316 stainless steel

Main seal: Flexityt

Alternatives are available, refer to the Design Options page

Design Conditions

Weight:	4 Kg
Design Pressure (MAWP):	6 Bar
Test Pressure:	10.2 Bar
Design Temperature Min:	-40°C
Design Temperature Max:	200°C

NOTE: The Design Conditions and Section View dimensions are for the specified part number only.

Design Code

BS EN14432

Design Approvals

Lloyds Register of Shipping

Range

Description	Part No.
Standard specification	468/7250B
Pneumatically actuated	468/7200BPN
With high-temperature seals	468/725HTB

Related Parts

Description	Part No.
CNAF/PTFE inlet gasket	5005-468
CNAF/PTFE outlet gasket	5005-469
Bolting kit (8x bolts, nuts, washers)	468/1100
4" BSP outlet flange	468/8047
4" BSP blank cap with PTFE seal	10304PSC

Section View

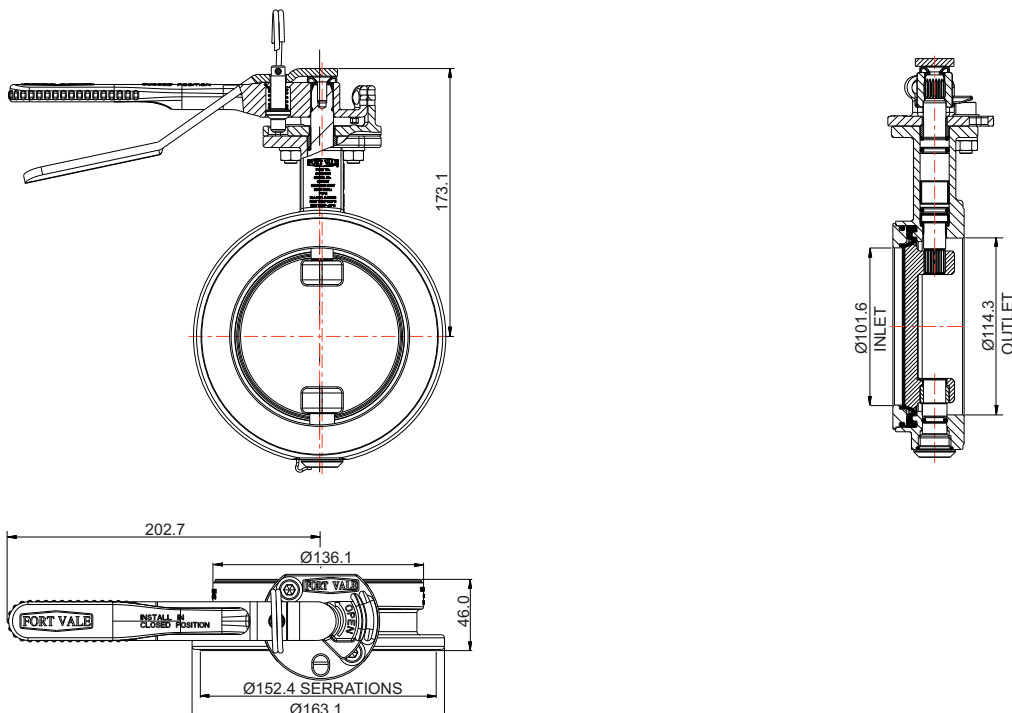



4" Clamped Butterfly Valve

Part No: 468/7250B

Parts Drawing

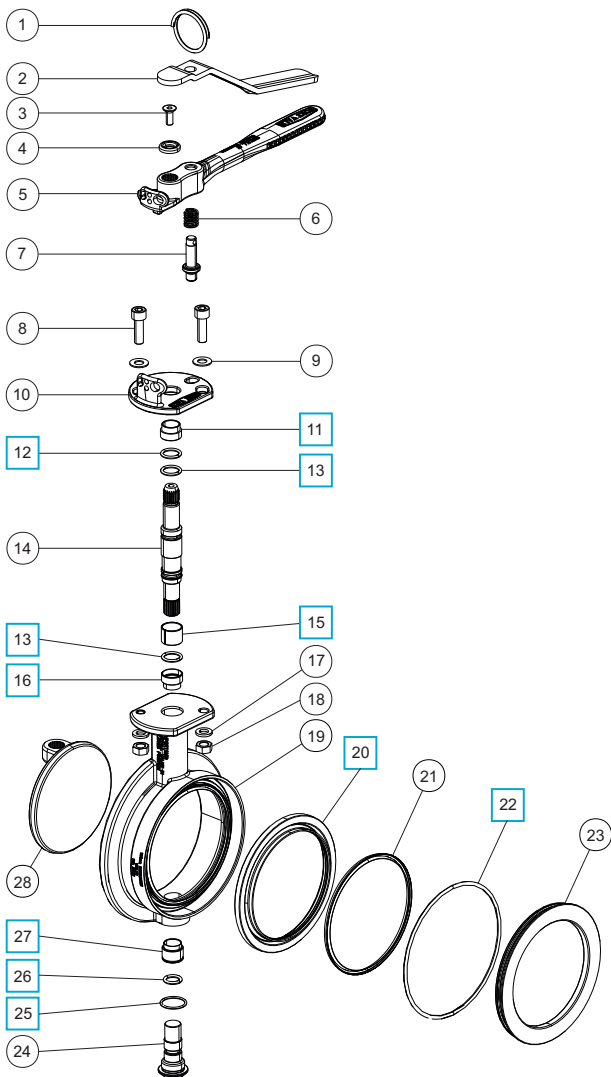

Parts List

Item	Description	Part No.	
1	Split ring	368/0011	
2	Operating lever	368/9837	
3	Countersunk set screw	5111-030	
4	Washer	20370	
5	Handle	368/0050	
6	Handle spring	368/0012	
7	Handle location pin	368/0010	
8	M8 cap screw (2)	5111-148	
9	M8 plain washer (2)	5113-005	
10	Stuffing clamp	368/0040	
11	PTFE stuffing clamp bush	368/0301	<input type="checkbox"/>
12	PTFE O ring	20363	<input type="checkbox"/>
13	Viton O ring (2)	20361	<input type="checkbox"/>
14	Spindle	368/0205	
15	Split bearing	368/0039	<input type="checkbox"/>
16	PTFE bearing	368/0009HT/1	<input type="checkbox"/>
17	M8 spring washer (2)	5113-003	
18	M8 full nut (2)	5112-001	
19	Body	468/0200	
20	Flexityt PTFE main seal	468/0030	<input type="checkbox"/>
21	Flexityt seal spring	468/0031	
22	Nitrile O ring	5005-357	<input type="checkbox"/>
23	Seal clamp plate	468/0033	
24	Bottom spindle	468/0005	
25	PTFE O ring	5005-160	<input type="checkbox"/>
26	High temperature seal	ORB614K1	<input type="checkbox"/>
27	PTFE bottom bush	468/0035	<input type="checkbox"/>
28	Closure plate	468/0400	

Seal Kit

Description	Part No.
All parts marked <input type="checkbox"/> in the Parts List	468/725SKB



TW100 Clamped Butterfly Valve

Part No: 468/5600B



Specification

Nominal size

100mm

Body type

Drilled 8 x 14mm holes on a 150mm PCD (TW100)

Properties

Left hand operated, lockable handle with TIR

Materials

Contact parts: 316 stainless steel

Main seal: Flexityt

Alternatives are available, refer to the Design Options page

Design Conditions

Weight:	4 Kg
Design Pressure (MAWP):	6 Bar
Test Pressure:	11 Bar
Design Temperature Min:	-40°C
Design Temperature Max:	200°C

NOTE: The Design Conditions and Section View dimensions are for the specified part number only.

Design Code

BS EN14432

Range

Description	Part No.
TW100 clamped valve	468/5600B
TW80 clamped valve	368/5500B

Related Parts

Description	Part No.
CNAF/PTFE TW100 inlet gasket	5005-832
CNAF/PTFE TW100 outlet gasket	5005-832/1
TW100 mating flange	875/8001
4" BSP eccentric TW100 outlet flange	468/5175

Section View

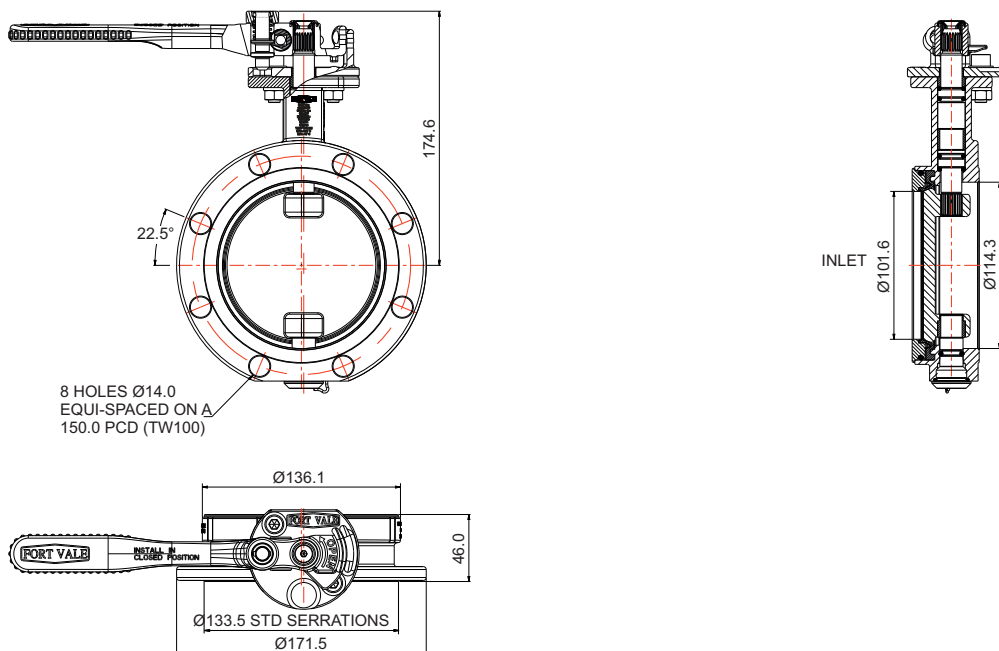



TW100 Clamped Butterfly Valve

Part No: 468/5600B

Parts Drawing

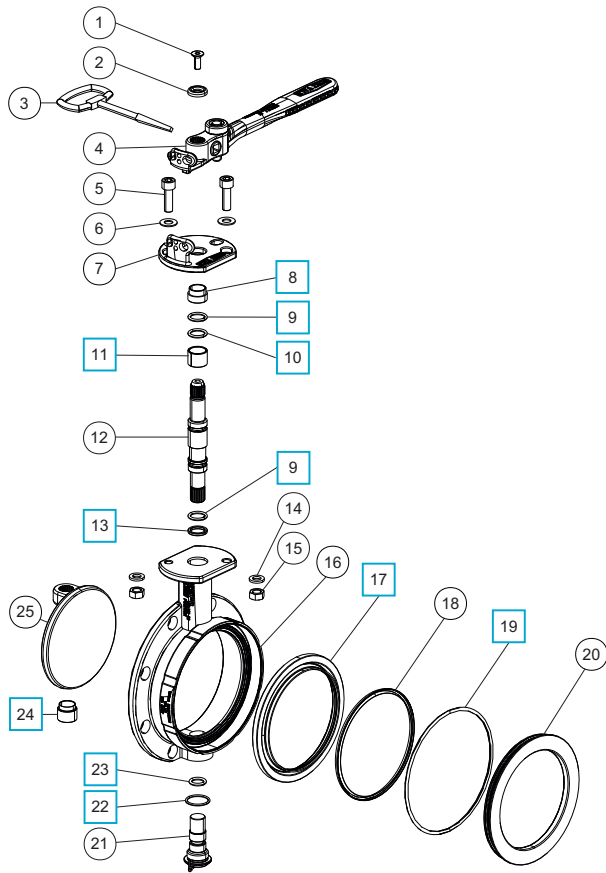

Parts List

Item	Description	Part No.	
1	Countersunk set screw	5111-030	
2	Retaining washer	20370	
3	Key	368/4625	
4	Barrel lock handle	368/0075	
5	M8 cap screw (2)	5111-148	
6	M8 plain washer (2)	5113-005	
7	Stuffing clamp	368/0041	
8	PTFE stuffing clamp bush	368/0301	<input type="checkbox"/>
9	PTFE O ring (2)	20363	<input type="checkbox"/>
10	Viton O ring	20361	<input type="checkbox"/>
11	Split bearing	252/0517	<input type="checkbox"/>
12	Spindle	368/0200	
13	PTFE bearing	368/0009	<input type="checkbox"/>
14	M8 flat spring washer (2)	5113-003	
15	M8 full nut (2)	5112-001	
16	TW100 body	468/0170	
17	Flextyt PTFE main seal	468/0030	<input type="checkbox"/>
18	Flextyt seal spring	468/0031	
19	Nitrile O ring	5005-357	<input type="checkbox"/>
20	Seal clamp plate	468/0033	
21	Bottom spindle	468/0005	
22	PTFE O ring	5005-160	<input type="checkbox"/>
23	Perfluoroelastomer O ring	ORB614K1	<input type="checkbox"/>
24	Bottom bush	468/0035	<input type="checkbox"/>
25	Closure plate	468/0400	

Seal Kit

Description	Part No.
All parts marked <input type="checkbox"/> in the Parts List	468/56SKB



6" Clamped Butterfly Valve

Part No: 668/0000



Specification

Nominal size

150mm

Body type

Clamped

Properties

Left hand operated, handle with TIR and padlock slots

Materials

Contact parts: 316 stainless steel

Main seal: Flextyt (spring-energized PTFE)

Alternatives are available, refer to the Design Options page

Design Conditions

Weight:	8.1 Kg
Design Pressure (MAWP):	4 Bar
Test Pressure:	7 Bar
Design Temperature Min:	-40°C
Design Temperature Max:	150°C

NOTE: The Design Conditions and Section View dimensions are for the specified part number only.

Design Codes

BS EN 14432

Related Parts

We can supply a complete discharge system and have a compatible range of

- 6" Cleanflow primary closure valves
- (pneumatic or hydraulic actuation)
- flanges
- fasteners
- gaskets
- tertiary closures.

Please contact Fort Vale for more information.

Section View

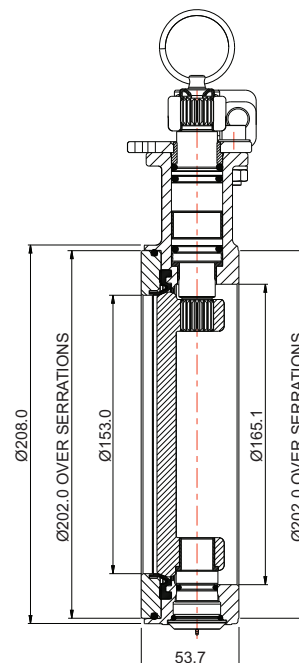
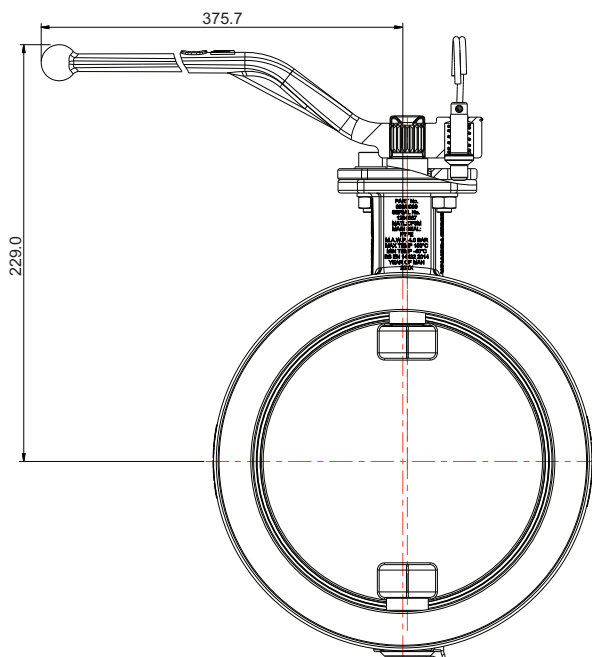



6" Clamped Butterfly Valve

Part No: 668/0000

Parts Drawing

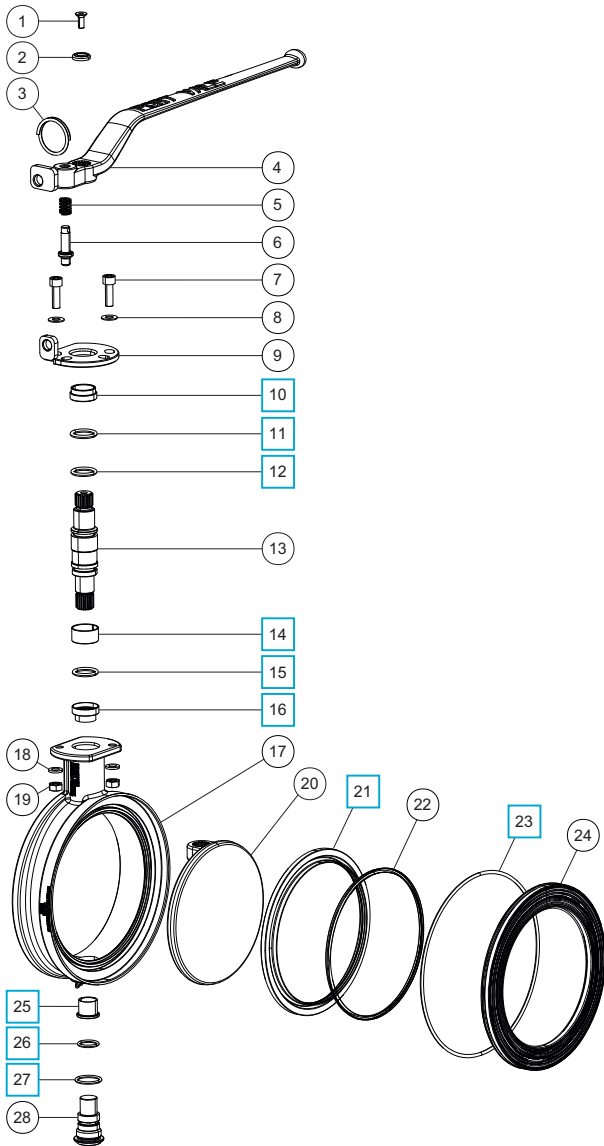

Parts List

Item	Description	Part No.
1	M6 countersunk bolt	5111-030
2	Retaining washer	20370
3	Split ring	368/0011
4	Handle	668/0023
5	Handle spring	368/0012
6	Handle location pin	368/0010
7	M8 cap screw (2)	5111-148
8	M8 plain washer (2)	5113-005
9	Stuffing clamp	668/0003
10	Stuffing clamp bush	359/4506 <input type="checkbox"/>
11	PTFE O ring	5005-111 <input type="checkbox"/>
12	Viton O ring	ORB212VR <input type="checkbox"/>
13	Spindle	668/0008
14	Split bearing	668/0009 <input type="checkbox"/>
15	Perfluoroelastomer O ring	ORB212K2 <input type="checkbox"/>
16	Top bearing	359/4509 <input type="checkbox"/>
17	Body	668/0010
18	M8 spring washer (2)	5113-003
19	M8 full nut (2)	5112-001
20	Closure plate	668/0020
21	Flexityt PTFE main seal	668/0001 <input type="checkbox"/>
22	Flexityt seal spring	668/0002
23	Nitrile O ring	ORB264N <input type="checkbox"/>
24	Seal clamp plate	668/0005
25	Bottom bush	359/4507 <input type="checkbox"/>
26	Perfluoroelastomer O ring	5005-370P <input type="checkbox"/>
27	PTFE O ring	ORB119P0 <input type="checkbox"/>
28	Lower spindle	668/0006

Seal Kit

Description	Part No.
All parts marked <input type="checkbox"/> in the Parts List	668/00SK



Butterfly Valve Top Discharge Assembly Installation Options

Example: 3" Flanged Butterfly Valve Top Discharge Assembly

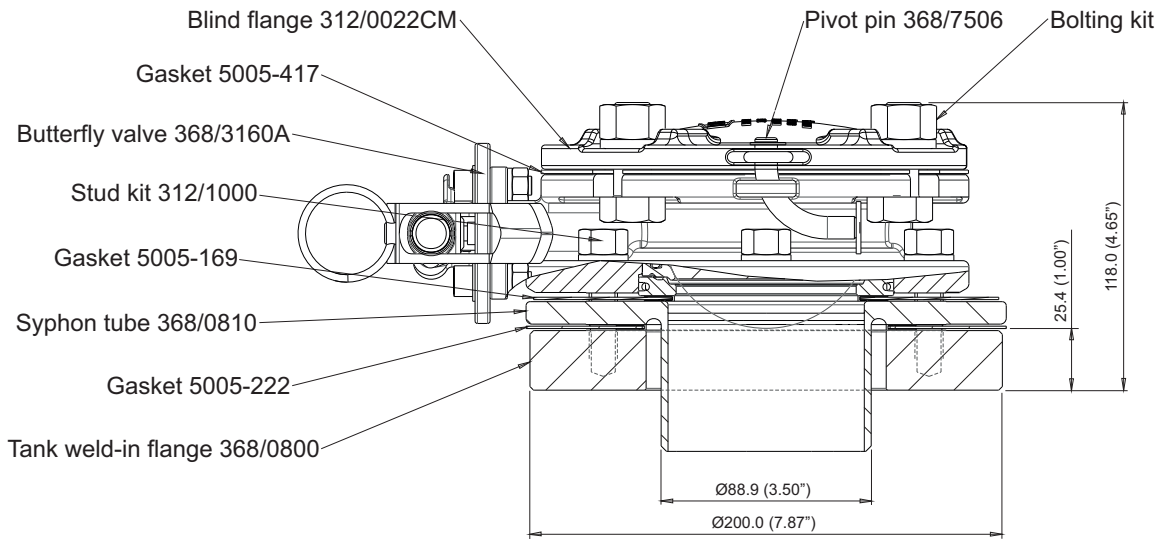



Bottom Discharge Assembly Installation Options

Example: 3" 3-Closure Bottom Discharge Assembly

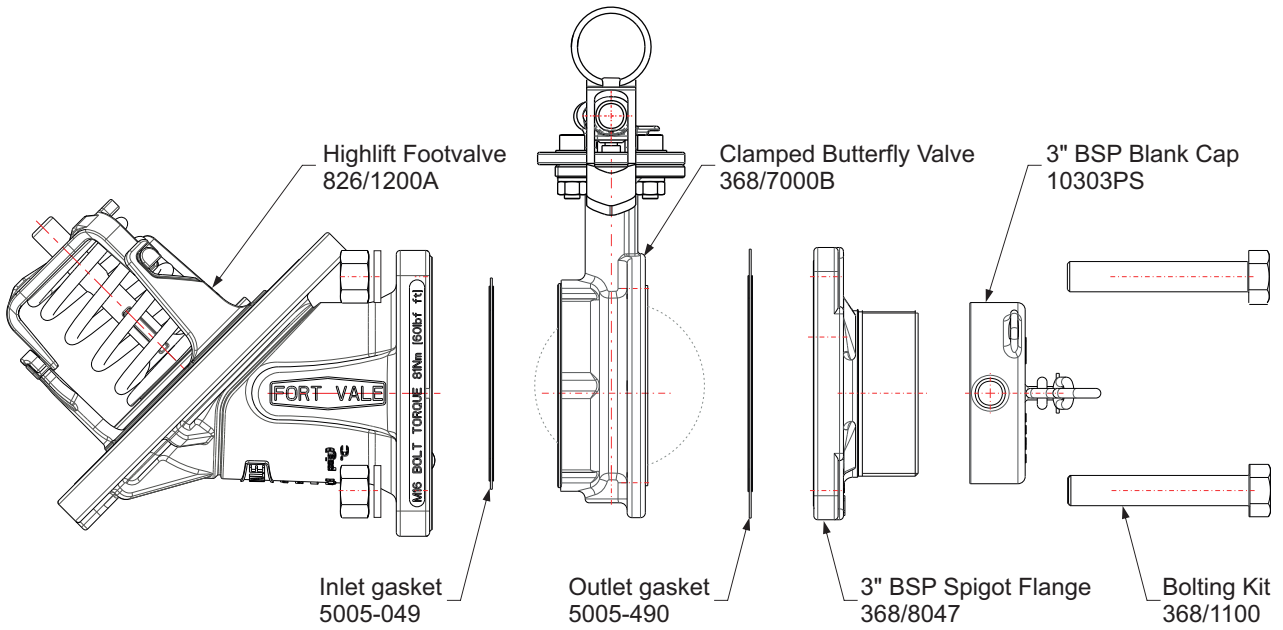



Discharge Butterfly Valves: Road Tanker Specification

Design Options

Function

A discharge butterfly valve is used to load and discharge cargo. It is usually a secondary closure valve that is installed after a footvalve (primary closure valve) at the drain point of a tank. Our road tanker discharge butterfly valves are designed to weld to the discharge pipework so that there is no need to centralise the valve.

We offer two types of road tanker discharge butterfly valves:

- DN80 (3") Tankpro - 3 piece valve
- DN80 (3") Unifly - 2 piece valve

NOTE: Refer to a separate page for discharge butterfly valves dedicated to tank containers and transportable tanks.

Design Options

The design options below are available on our standard range of Tankpro and Unifly discharge butterfly valves.

DN80 (3") Tankpro

Operation

Manually operated
Pneumatically actuated

Inlet

None
Straight
Angled

Valve Materials

316 stainless steel
Special service conditions:
High nickel alloys

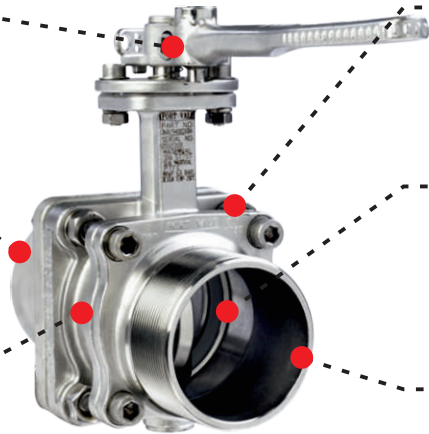

Body

Non-vented
Vented: 3/8" BSP
Vented: 3/8" NPT

Main Seal

PTFE
Special service conditions:
High-temperature compatible seals

Outlet

3" BSP
3" BSP extended
3" NPT
Weld prepared

DN80 (3") Unifly

Operation

Manually operated
Pneumatically actuated

Inlet

None
Straight
Angled
85mm I/D

Valve Materials

316 stainless steel
Special service conditions:
High nickel alloys

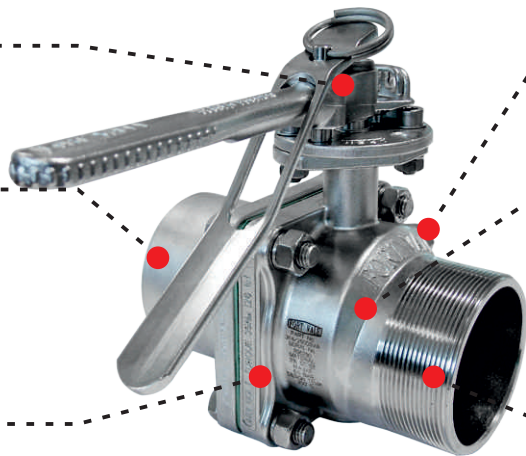

Body

Non-vented
Vented: 3/8" BSP

Main Seal

PTFE
Special service conditions:
High-temperature compatible seals

Outlet

3" BSP
3" BSP extended



Discharge Butterfly Valves: Road Tanker Specification Design Options

Related Parts

We recommend our range of compatible accessories:

- Flanges - inlet, adapter, outlet
- Tertiary closures
- Fasteners

Please contact us for more information about these parts.

Discharge Butterfly Valves for Dedicated Service

We offer a range of discharge butterfly valves suitable for these service conditions and special cargoes:

- Tank containers & transportable tanks
- Hygienic service

Please contact us for more information about these valves.



3" Tankpro Road Tanker Butterfly Valve

Part No: 368/9400SXBA



Specification

Nominal size

80mm

Body type

Weld-prepared inlet, 3" BSP threaded outlet

Properties

Left hand operated, lockable handle with TIR

Materials

Contact parts: 316 stainless steel

Main seal: PTFE

Alternatives are available, refer to the Design Options page

Design Conditions

Weight:	6.15 Kg
Design Pressure (MAWP):	6 Bar
Test Pressure:	11 Bar
Design Temperature Min:	-40°C
Design Temperature Max:	200°C

NOTE: The Design Conditions and Section View dimensions are for the specified part number only.

Approvals

BS EN14432

Lloyds Register of Shipping Design Appraisal: DCF9376/1

Rijksdienst voor het Wegverkeer Approval: VLG S-9301

Range

Body	Outlet	Part No.
Non-vented	3" BSP standard	368/9400SXBA
Vented 3/8" BSP	3" BSP standard	368/9400SVBA
Non-vented	3" BSP extended	368/9400SXEA
Vented 3/8" BSP	3" BSP extended	368/9400SVEA

Related Parts

Description	Part No.
3" BSP blank cap with PTFE seal	10303PS
Conversion mounting kit	368/9401KIT

Section View

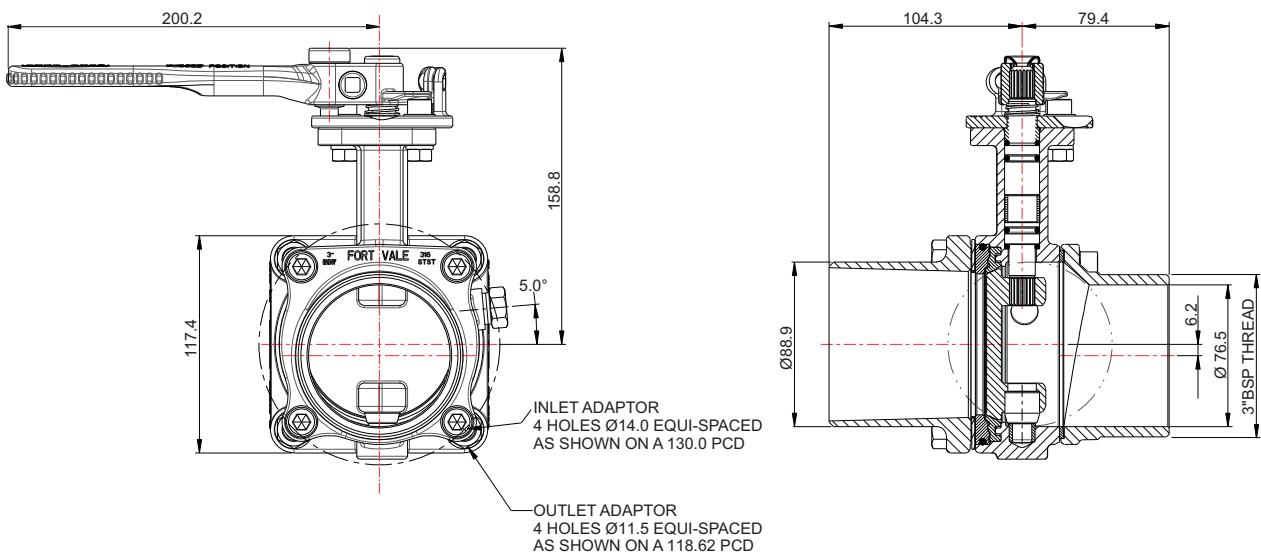



3" Tankpro Road Tanker Butterfly Valve

Part No: 368/9400SXBA

Parts Drawing

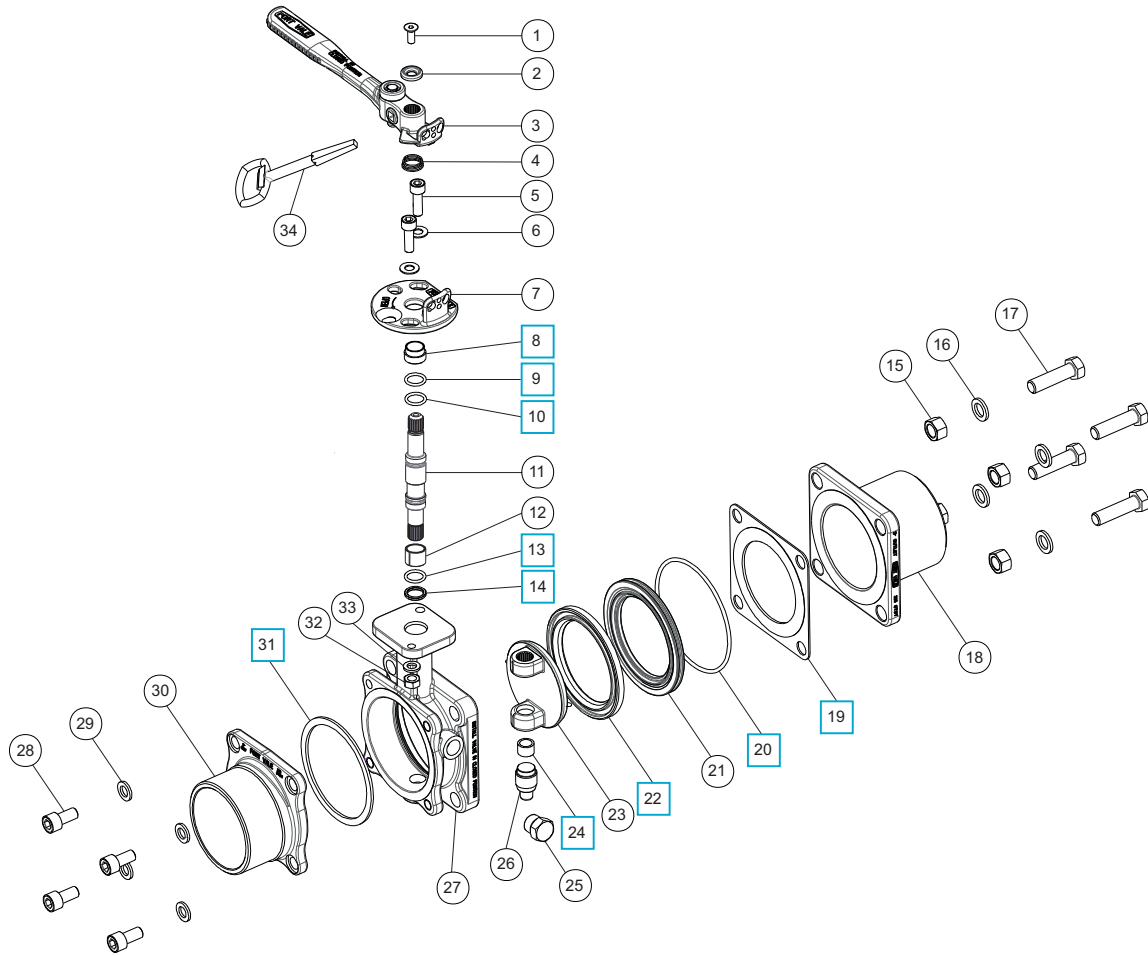

Parts List

Item	Description	Part No.
1	M6 socket head set screw	5111-030
2	Washer	20370
3	Handle	368/0075
4	Electrical continuity spring	368/0014
5	M8 socket head cap screw (2)	5111-148
6	M8 plain washer (2)	5113-005
7	Stuffing plate	368/0041
8	Stuffing clamp bush	368/0301 <input type="checkbox"/>
9	PTFE O ring	20363 <input type="checkbox"/>
10	Viton O ring	20361 <input type="checkbox"/>
11	Spindle	368/0200
12	Split bearing	252/0517
13	Perfluoroelastomer O ring	5005-586 <input type="checkbox"/>
14	PTFE spindle seat	368/0009 <input type="checkbox"/>
15	M12 full nut (4)	5112-006
16	M12 spring washer (4)	5113-010
17	M12 hex head set screw (4)	5111-023
18	Inlet adaptor *Note	368/9410
19	CNAF/PTFE inlet gasket	5005-707 <input type="checkbox"/>
20	Nitrile O ring	5005-342 <input type="checkbox"/>

Parts List

Item	Description	Part No.
21	Seal clamp	368/9148
22	PTFE main seal	368/0002 <input type="checkbox"/>
23	Closure plate	368/0400
24	Bottom spindle bush	368/0035 <input type="checkbox"/>
25	3/8" taper plug *Note	5128-0XX
26	Bottom spindle	368/0036
27	Body (non-vented) *Note	368/9420A
28	M10 socket head cap screw (4)	5111-053
29	M10 spring washer (4)	5113-002
30	3" BSP outlet *Note	368/9430
31	PTFE outlet seal	5005-706 <input type="checkbox"/>
32	M8 full nut (2)	5112-001
33	M8 spring washer (2)	5113-003
34	Key	368/4625

NOTE: The valve specification changes the part number

Seal Kit

Description	Part No.
All parts marked <input type="checkbox"/> in the Parts List	368/94SK



3" Unify Road Tanker Butterfly Valve

Part No: 368/2500SVA

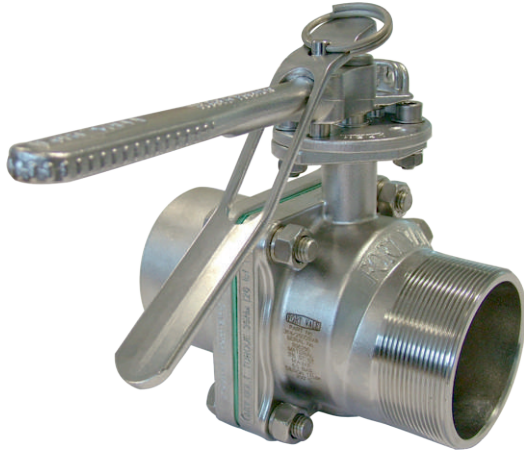

Specification

Nominal size

80mm

Body type

Weld-prepared inlet, 3" BSP threaded outlet

Properties

Left hand operated, handle with TIR

Materials

Contact parts: 316 stainless steel

Main seal: PTFE

Alternatives are available, refer to the Design Options page

Design Conditions

Weight:	5.76 Kg
Design Pressure (MAWP):	6 Bar
Test Pressure:	11 Bar
Design Temperature Min:	-40°C
Design Temperature Max:	200°C

NOTE: The Design Conditions and Section View dimensions are for the specified part number only.

Design Code

BS EN14432

Range

Body	Inlet Adaptor	Part No.
Vented 3/8" BSP	Straight	368/2500SVA
Non-vented	Straight	368/2500SNA
Vented 3/8" BSP	None	368/2500NVA
Non-vented	None	368/2500NNA
Vented 3/8" BSP	Angled	368/2500AVA
Non-vented	Angled	368/2500ANA
Vented 3/8" BSP	85mm I/D	368/2500BVA
Non-vented	85mm I/D	368/2500BNA

Related Parts

Description	Part No.
3" BSP blank cap with PTFE seal	10303PS

Section View

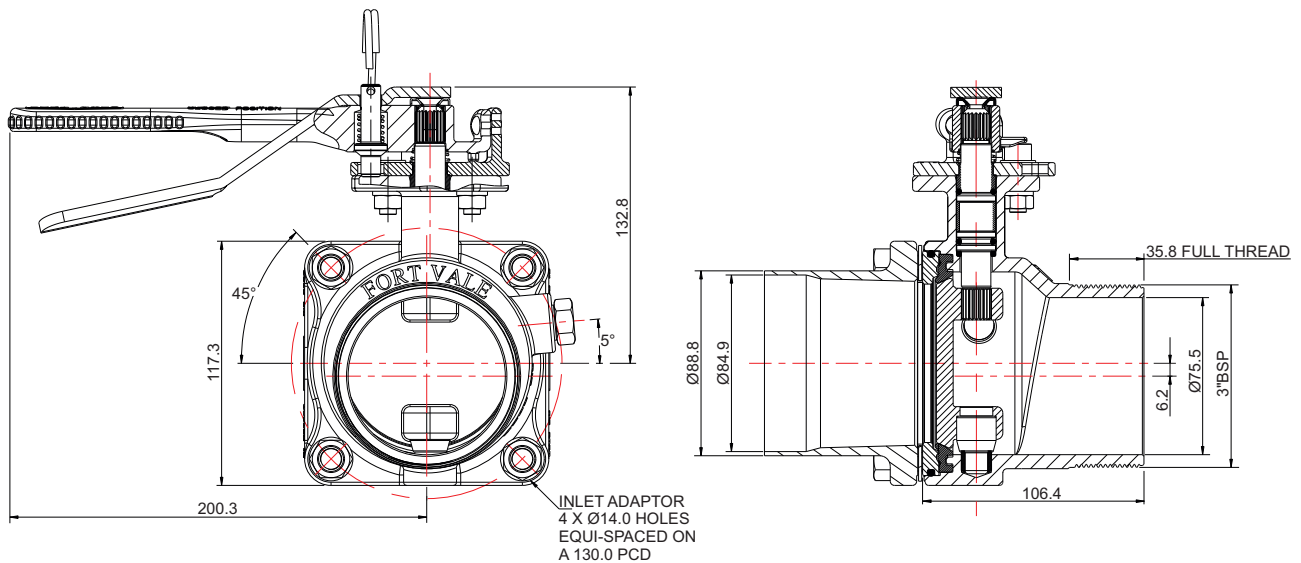



3" Unifly Road Tanker Butterfly Valve

Part No: 368/2500SVA

Parts Drawing

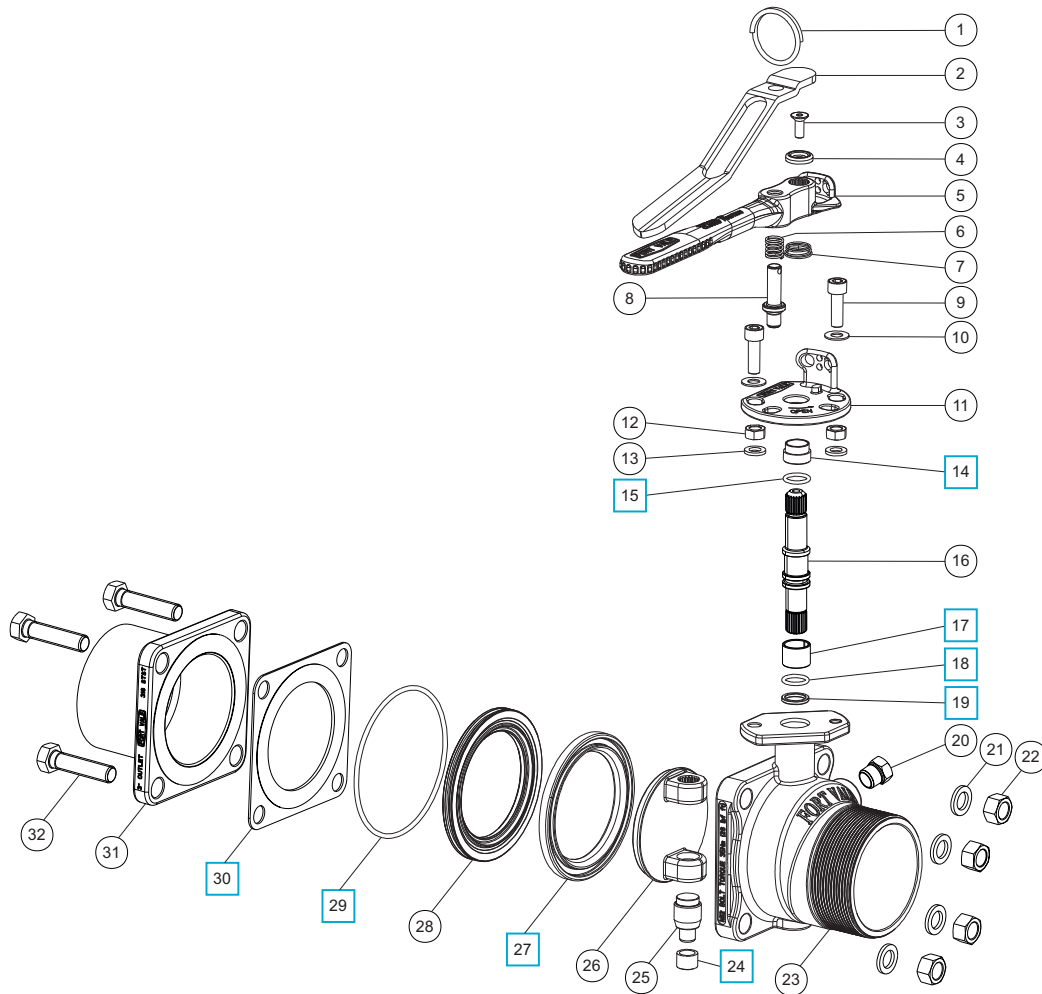

Parts List

Item	Description	Part No.	
1	Split ring	368/0011	
2	Handle lever	368/9837	
3	Countersunk bolt	5111-030	
4	Retaining washer	20370	
5	Handle	368/0050	
6	Handle spring	368/0012	
7	Electrical continuity spring	368/0014	
8	Handle location pin	368/0010	
9	M8 cap screw (2)	5111-148	
10	M8 plain washer (2)	5113-005	
11	Stuffing clamp	368/0040	
12	M8 full nut (2)	5112-001	
13	M8 spring washer (2)	5113-003	
14	Stuffing clamp bush	368/0301	□
15	PTFE O ring	20363	□
16	Spindle	368/0201	
17	Split bearing	252/0517	□
18	Viton O ring	20361	□
19	PTFE spindle seat	368/0009	□

Parts List

Item	Description	Part No.	
20	3/8" taper plug	5128-011	
21	M12 spring washer (4)	5113-010	
22	M12 full nut (4)	5112-006	
23	Vented body *Note	368/2520	
24	Bottom bush	368/0035	□
25	Bottom spindle	368/0036	
26	Closure plate	368/0400	
27	PTFE main seal	368/0002	□
28	Seal clamp	368/9148	
29	Nitrile O ring	5005-342	□
30	CNAF/PTFE gasket	5005-707	□
31	Inlet flange *Note	368/9410	
32	M12 hex bolt (4)	5111-032	

NOTE: The valve specification changes the part number

Seal Kit

Description	Part No.
All parts marked □ in the Parts List	368/25SK



APPENDIX

Catalogue

A	Bolt Torque Guide & Step Loading Procedure
B	Client Responsibilities - Valves & Accessories

THIS PAGE IS INTENTIONALLY BLANK



Bolt Torque Guide & Step Loading Procedure

Installation & Operating Instructions

Flange Bolting

CAUTION: Weld-distortion and too much tightening force will cause damage to a flange.

It is important not to cause damage to weld-in flanges and mating flanges. If a flange is damaged it will not give a satisfactory seal when a gasket and secondary mating flange is installed.

Bolt-stress can decrease after initial tightening. The cause can be deformation of the gasket material, particularly with soft materials such as a CNAF/PTFE envelope gasket.

Best procedure recommends that, after initial bolting, the flange joint is tightened again after a period of time. Most gasket manufacturers advise a period of 24 hours. ASME PCC-1-2000 GUIDELINES FOR PRESSURE BOUNDARY BOLTED FLANGE JOINT ASSEMBLY advises a minimum period of 4 hours.

Bolt torque calculations are based on a flat flange to within 0.15mm.

Recommended bolt torque values will be reduced if a lubrication is used.

Bolt Torque

Bolt Torque Values

Fort Vale bolt torque values are given as a reference guide only and are based on:

- the use of a CNAF/PTFE gasket.
- unlubricated fasteners.
- a flange flat to within 0.15mm.

CAUTION: If you use a different gasket material, a lubricant or a flange with distortion, you must re-calculate the torque value.

Bolt Torque Procedure

To install flanged parts correctly:

- Examine the mating flange of the part.
- If the flange is marked with a torque value, obey that torque value.
- If there is no torque value marked on the mating flange, obey the bolt torque values given in Table BT1.
- Tighten the bolts evenly in sequence. Refer to Figure BT1.
- Obey the Step Loading Procedure (ASME PCC-1-2000). Refer to the next page.

Table BT1

Thread	Torque Value
M10	30 Nm (22 lbf.ft)
M12	65 Nm (48 lbf.ft)
M16	81 Nm (60 lbf.ft)

Figure BT1

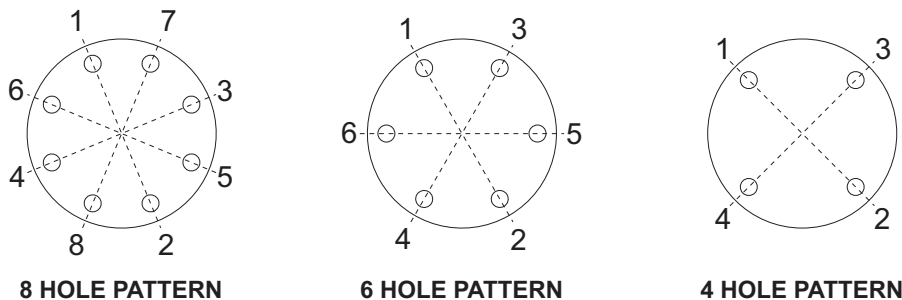



Bolt Torque Guide & Step Loading Procedure

Installation & Operating Instructions

Step Loading Procedure

To install flanged parts correctly, obey the Step Loading Procedure extract from ASME PCC-1-2000:

Install

Hand tighten, then “snug up” to 15 Nm (10 lbf.ft) to 30 Nm (20 lbf.ft) (not to exceed 20% of Target Torque). Check flange gap around circumference for uniformity. If the gap around the circumference is not reasonably uniform, make the appropriate adjustments by selective tightening before proceeding.

Round 1

Tighten to 20% to 30% of Target Torque. Check flange gap around circumference for uniformity. If the gap around the circumference is not reasonably uniform, make the appropriate adjustments by selective tightening before proceeding.

Round 2

Tighten to 50% to 70% of Target Torque. Check flange gap around circumference for uniformity. If the gap around the circumference is not reasonably uniform, make the appropriate adjustments by selective tightening before proceeding.

Round 3

Tighten to 100% of Target Torque. Check flange gap around circumference for uniformity. If the gap around the circumference is not reasonably uniform, make the appropriate adjustments by selective tightening before proceeding.

Round 4

Continue tightening the bolts, but on a rotational clockwise pattern until no further nut rotation occurs at the Round 3 Target Torque value. For indicator bolting, tighten bolts until the indicator rod retraction readings for all bolts are within the specified range.

Round 5

Time permitting, wait a minimum of 4 hr and repeat Round 4; this will restore the short-term creep relaxation/embedment losses. If the flange is subjected to a subsequent test pressure higher than its rating, it may be desirable to repeat this round after the test is completed.



Client Responsibilities - Valves & Accessories

Installation, Operation & Maintenance Instructions

Compatibility

Make sure that the function and technical specification of the valve/accessory is compatible with the vessel service conditions and the cargo. This includes, but is not limited to:

- dimensions.
- pressure/vacuum setting.
- air/vapour/liquid flow capacity.
- maximum allowable working pressure.
- test pressure.
- minimum/maximum design temperatures.
- materials of construction.

Maintenance and Inspection

Fort Vale valves and accessories have a long life if you use them correctly in compatible service conditions. It is not necessary to lubricate the parts, but we recommend that you do the inspections that follow:

Inspections at regular intervals:

1. Examine the valve to make sure there is no damage, wear or corrosion.
2. Examine the valve and adjacent area to make sure there is no leakage of cargo.
3. Examine the fasteners to make sure they are not loose.
4. Make sure the valve operates correctly.

CAUTION: If you operate the valve with very corrosive cargo, or near its temperature and/or pressure limit (very high or very low temperature and/or pressure), do the inspections more frequently.

Also, schedule regular maintenance based on how frequently the valve is used, the type of cargo and the service conditions.

Inspections after 2½ years of service or a minor incident:

1. Examine the valve to make sure there is no damage, wear or corrosion.
2. Make sure the valve operates correctly.
3. Do a pressure test on the valve.

Inspections after 5 years of service or a major incident:

1. Disassemble and clean the valve.
2. Replace all the valve seals and do a pressure test.

Replacement Parts

Do not adapt or change the valve. If you install a replacement part, it must be a genuine Fort Vale part.

WARNING: If you install a part that is not genuine, there is a risk of:

- injury to personnel.
- permanent damage to the valve.
- permanent damage to the vessel.
- valve malfunction.

External Fire

If you install the valve in an area where there is a risk of external fire, you must install compatible accessories to prevent damage to the valve.

Compatibility of Accessories

Accessory components must cause no interference with the valve's function. Accessories must be made from compatible materials that will cause no damage to the valve materials. Do not install an accessory that will cause an increased load on the valve, such as mechanical, static, dynamic or thermal load.

Mis-use

Obey the instructions and recommended procedures in the installation and operating instructions. Obey the pressure and temperature markings on the valve and on the drawing. Use the valve/accessory for its correct function only. Fort Vale accept no liability or responsibility for incorrect use of the valve/accessory.

THIS PAGE IS INTENTIONALLY BLANK



Our subsidiaries are located in:

US Office

126 N. Virginia
La Porte
TX 77571
USA

Tel: +1 281 471 8100

Fax: +1 281 471 8116

Email: ussales@fortvale.com

Head Office

Calder Vale Park
Simonstone Lane
Simonstone, Burnley
Lancashire, BB12 7ND, UK

Tel: +44 (0) 1282 687120

Fax: +44 (0) 1282 687110

Email: sales@fortvale.com

China Office

Fort Vale Engineering Shanghai Ltd
Building 11 88 Yuanshan Road
Xinzhuang Industry Park
Shanghai 201108 China

Tel: +86 21 6442 1367

Fax: +86 21 6442 1376

Email: cnsales@fortvale.com

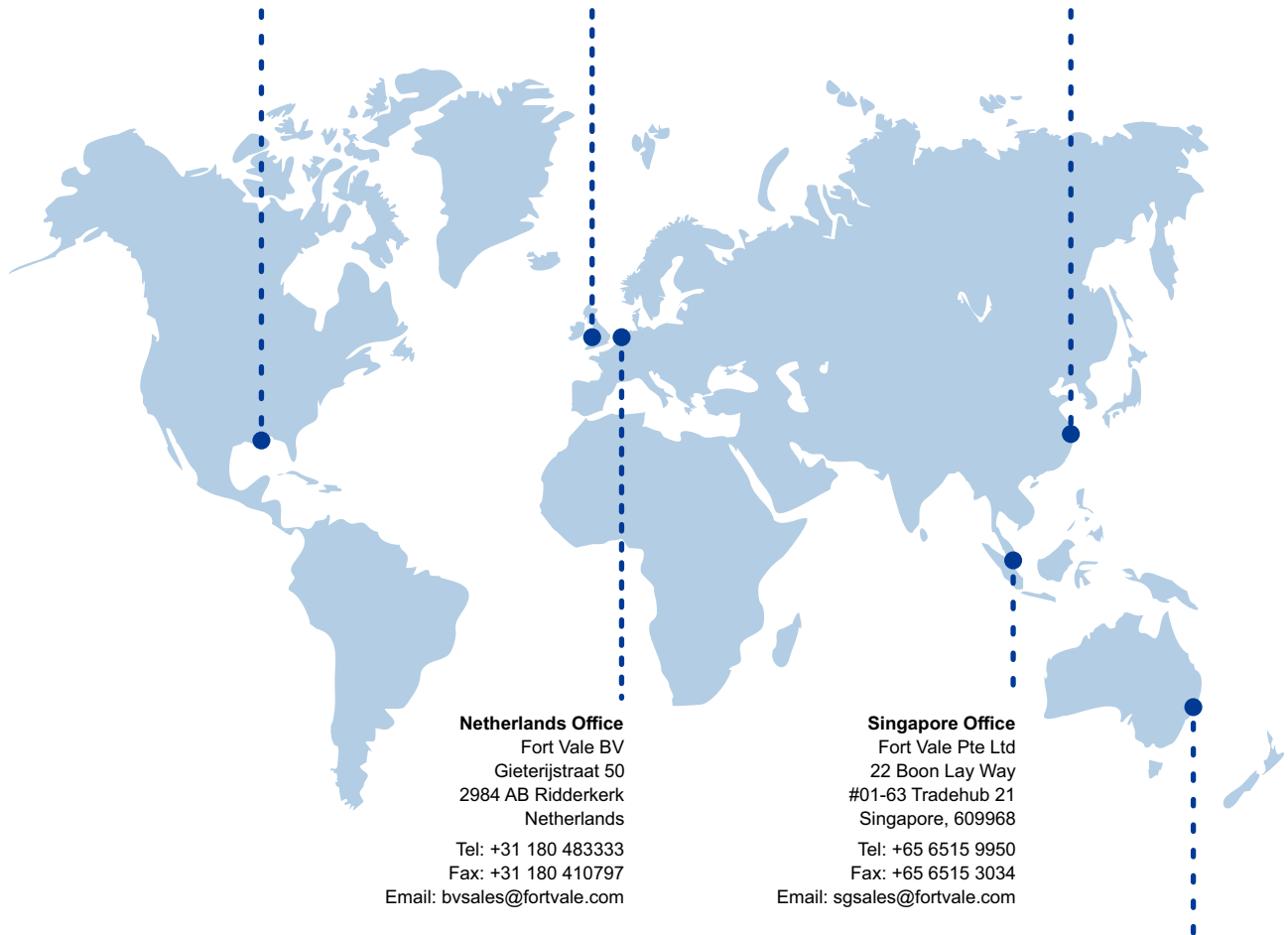

Netherlands Office

Fort Vale BV
Gieterijstraat 50
2984 AB Ridderkerk
Netherlands

Tel: +31 180 483333

Fax: +31 180 410797

Email: bvsales@fortvale.com

Singapore Office

Fort Vale Pte Ltd
22 Boon Lay Way
#01-63 Tradehub 21
Singapore, 609968

Tel: +65 6515 9950

Fax: +65 6515 3034

Email: sgsales@fortvale.com

Australia Office

Fort Vale Australia Pty Ltd
Bellwood Business Park
Unit 14, 49 Bellwood Street
Darra, Queensland, 4076

Tel: +61 7 3189 5059

Email: ausales@fortvale.com

We also have Authorised Distributors around the world to provide you with product sales and after-market services. To find your nearest distributor, please visit our website - www.fortvale.com

