



Catalogue

Standard Range of Super Maxi & Hyper Maxi Relief Valves



CONTENTS

Super Maxi & Hyper Maxi Relief Valves

Catalogue

Design Options: Super Maxi & Hyper Maxi Relief Valves	3
Super Maxi Relief Valves: 2½” BSP Connection	
Pressure Only: Up to 5.15 Bar	5
Pressure/Vacuum: Up to 5.15 Bar Pressure and 88 kPa Vacuum	7
Pressure Only: 5.2 Bar to 11.1 Bar	9
Pressure Only: 11.2 Bar to 16 Bar	11
Super Maxi Relief Valves: 65mm Flanged Connection	
Pressure Only: Up to 4.8 Bar	13
Pressure/Vacuum: Up to 4.8 Bar Pressure and 88 kPa Vacuum	15
Pressure Only: 5.2 Bar to 11.4 Bar	17
Pressure Only: 11.2 Bar to 16 Bar	19
Hyper Maxi Relief Valves: 82.5mm Flanged Connection	
Pressure Only: Up to 5.15 Bar	21
Pressure/Vacuum: Up to 5.15 Bar Pressure and 88 kPa Vacuum	23
Pressure Only: From 5.5 Bar to 14.3 Bar	25
Pressure/Vacuum: From 5.5 Bar to 14.3 Bar Pressure and up to 88 kPa Vacuum	27

Continued over



CONTENTS

Super Maxi & Hyper Maxi Relief Valves

Catalogue

Accessories

Installation Options: Super Maxi & Hyper Maxi Relief Valves	29
Burst Discs	30
Flame Arresters & Debris Protection	32
Flanges: DN65 flanges for Super Maxi Relief Valves	33
Flanges: DN80 flanges for Super Maxi & Hyper Maxi Relief Valves	34
Pressure Gauges	35
Weld-in Sockets	36
Valve Repair & Maintenance	37
Appendix	39
Bolt Torque Guide & Step Loading Procedure	41
Client Responsibilities	43
Fort Vale Worldwide	45



Super Maxi & Hyper Maxi Relief Valves

Design Options

Function

A Super Maxi or Hyper Maxi is a spring-loaded relief valve which is installed in the vapour space of a tank. It is pre-set to be compatible with the service conditions and it vents to protect the tank from accidental over-pressure or unwanted vacuum conditions.

Super Maxi & Hyper Maxi relief valves have a high flow performance to prevent the catastrophic failure of a tank. This type of valve is often used on tanks carrying hazardous cargo.

We offer a range of relief valves for different service conditions and flow requirements. Contact us for more information.

Design Options

The design options below are available on our standard range of Super Maxi & Hyper Maxi relief valves.

Tank Connection

2½" BSP

Flanged with holes or slots: a selection of drilling patterns is available

Special service conditions:
DIN11851: 80mm



Special Options

Manual vacuum vent button

Tank Seal

Rubber/PTFE - 2½" BSP only
Other materials are available

Nominal Bore

65mm: Super Maxi

82.5mm: Hyper Maxi

Special service conditions:
Tapered bore: 65mm to 80mm



Body

Standard body:
Super Maxi: ≤ 4.8 Bar
Hyper Maxi: ≤ 5.15 Bar

Extended body:
Super Maxi: ≥ 4.55 Bar
Hyper Maxi: ≥ 5.15 Bar

Pressure Setting

Super Maxi: 0.15 Bar to 16 Bar
Hyper Maxi: 0.15 Bar to 14.3 Bar

Pressure Seal

Fortyt

Special service conditions:
A range of seal materials is available

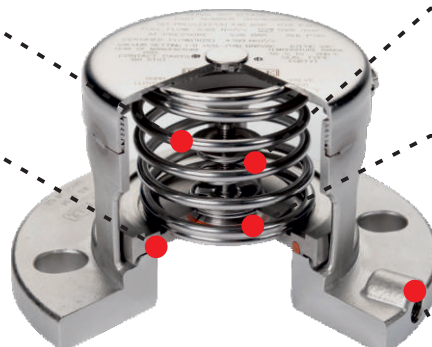

Vacuum Setting

From 2 kPa to 88 kPa

Vacuum Seal

Fortyt

Special service conditions:
A range of seal materials is available

Gauge Connection

Flanged valves only:
¼" BSP (standard)
¼" NPT (special)



Super Maxi & Hyper Maxi Relief Valves

Design Options

Design Options - continued

Valve Materials

316 stainless steel

Special service conditions:

Lined/coated wetted parts e.g. PFA

High nickel alloys



Finish

Electropolished

Special service conditions:

Corrosion-resistant paint on external surfaces to prevent damage from corrosive cargo vapour/splash

Related Parts

We recommend our range of compatible accessories:

- Flame arrester or gauzed cowl ***Note**
- Burst discs ***Note**
- Pressure gauges
- Flanges - weld-in and adaptor
- Weld-in sockets
- Gaskets
- Fasteners

NOTE: If you install an accessory item, e.g. a flame arrester, cowl, burst disc or baffle, it will decrease the air flow capacity of the relief valve. Thus, you must calculate again to make sure that the decreased flow capacity will give sufficient protection to your vessel/system.

Please contact us for more information about these parts.

Relief Valves for Dedicated Service

We offer a range of relief valves for these service conditions and special cargoes:

- T50 tank containers for liquefied gas
- Rail tank wagons
- U.S. tank trucks
- IBCs and small capacity tanks
- Steam-heating systems for tanks
- Hygienic service
- Food grade for liquid flow

Please contact us for more information about these valves.



2½” BSP Super Maxi Relief Valve - Pressure Only

Part No: 010/1XXX00 - Metric Setting



Specification

Nominal size
DN65

Tank connection
2½” BSP

Set pressure
From 0.15 Bar to 5.15 Bar

Materials
Contact parts: 316 stainless steel
Pressure O ring: Fortyt
Tank seal: Rubber/PTFE envelope

Alternatives are available, refer to the Design Options page

Design Conditions

Weight: 2.9 Kg
Design Pressure (MAWP): 5.2 Bar
Test Pressure: 10.1 Bar
Design Temperature Min: -55°C
Design Temperature Max: 200°C

NOTE: The working temperature of the pressure O ring can change the design temperature limits. The Design Conditions and Section View dimensions are for the specified part number only.

Approval

Design Approval by Lloyds Register of Shipping

WARNING: If you install an approved relief valve accessory item, e.g. a flame arrester, cowl, burst disc or baffle, it will decrease the air flow capacity of the relief valve. Thus, you must calculate again to make sure that the decreased air flow capacity will give sufficient protection to your vessel/system. Refer to Fort Vale for more information.

Range

Standard Settings	Part No.
2.19 Bar	010/121900
3.31 Bar	010/133100
3.71 Bar	010/137100
4.40 Bar	010/144000

Related Parts

Description	Part No.
2½” BSP weld-in socket	600/1000
2½” BSP burst disc adaptor assembly	176/7020
Tank weld-in flange	176/3150
Burst disc adaptor flange	176/7001
65mm burst disc - refer to Fort Vale	862/XXXX
CNAF/PTFE gasket (adaptor flange)	5005-398
0-7 Bar pressure gauge, brass internal parts	921/07BBSP
0-7 Bar pressure gauge, stainless steel internal parts	920/07BBSP
Flame arrester *Warning	176/2900
Gauzed cowl *Warning	176/6000

Section View

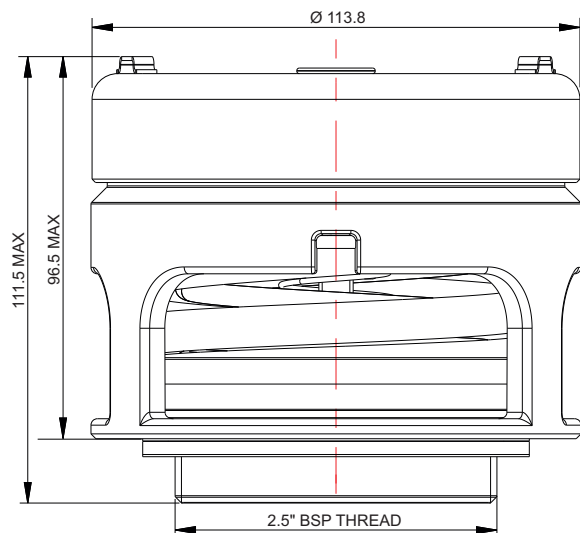
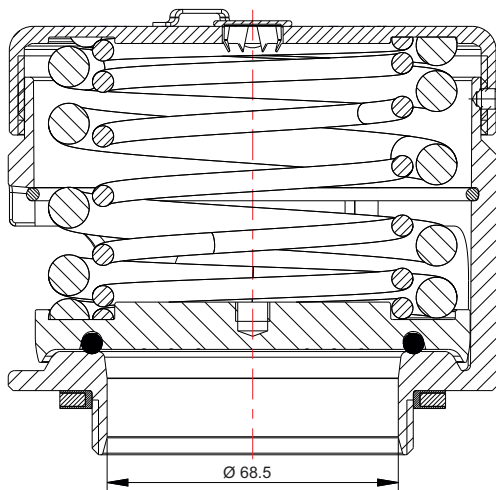



2 1/2" BSP Super Maxi Relief Valve - Pressure Only

Part No: 010/1XXX00 - Metric Setting

Parts Drawing

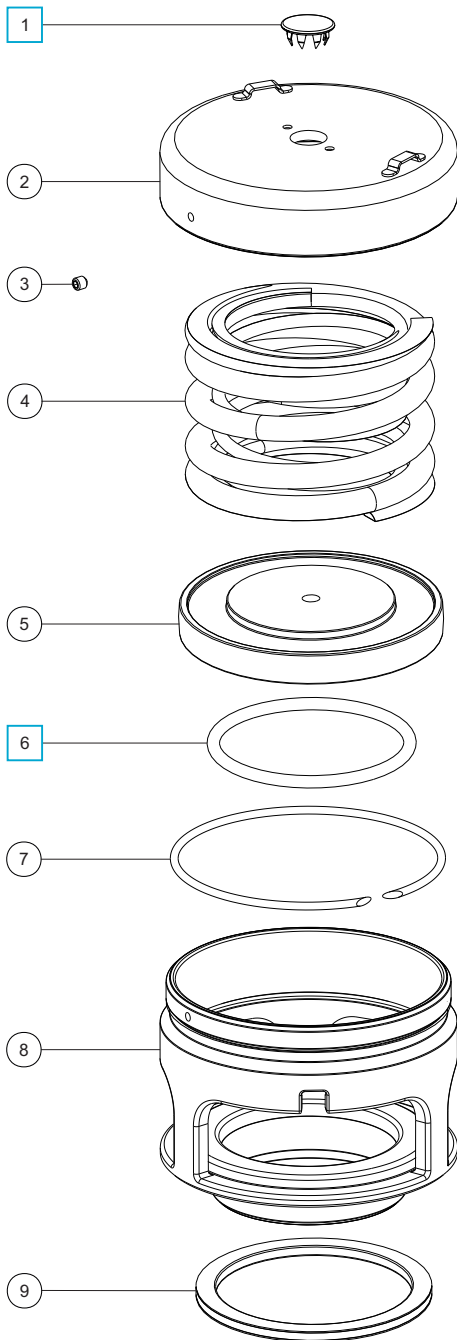

Parts List

Item	Description	Part No.
1	Stainless steel plug	10978
2	Cap *Note	1760/0005XX
3	Anti-tamper screw	5121-001
4	Pressure springs	Refer to Table 1
5	Pressure plate *Note	1860/005XXX
6	Fortyt pressure O ring	5005-101
7	Retaining ring clip	5120-067
8	Body	1860/0100
9	Rubber/PTFE envelope seal	5005-046

NOTE: The valve specification changes the Part No.

Table 1

Std. Pressure Settings	Pressure Spring Part No.
2.19 Bar	6104-0252
3.31 Bar	6104-0112 & 6104-0252
3.71 Bar	6104-0422 (Pair)
4.40 Bar	6104-0485 (Pair)

Pressure springs are available from 0.15 Bar to 5.15 Bar

Seal Kit

Description	Part No.
All parts marked <input type="checkbox"/> in the Parts List	000/1PSK



2½” BSP Super Maxi Relief Valve - Pressure/Vacuum

Part No: 010/1XXXXX - Metric Setting



Specification

Nominal size

DN65

Tank connection

2½” BSP

Set pressure

From 0.15 Bar to 5.15 Bar

Set vacuum

From 1 kPa to 88 kPa

Materials

Contact parts: 316 stainless steel

Pressure O ring: Fortyt

Vacuum O ring: Fortyt

Tank seal: Rubber/PTFE envelope

Alternatives are available, refer to the Design Options page

Design Conditions

Weight:	2.9 Kg
Design Pressure (MAWP):	5.2 Bar
Test Pressure:	10.1 Bar
Design Temperature Min:	-55°C
Design Temperature Max:	200°C

NOTE: The working temperature of the pressure and vacuum O rings can change the design temperature limits. The Design Conditions and Section View dimensions are for the specified part number only.

Approval

Design Approval by Lloyds Register of Shipping

WARNING: If you install an approved relief valve accessory item, e.g. a flame arrester, cowl, burst disc or baffle, it will decrease the air flow capacity of the relief valve. Thus, you must calculate again to make sure that the decreased air flow capacity will give sufficient protection to your vessel/system. Refer to Fort Vale for more information.

Range

Standard Settings	Part No.
2.19 Bar & 21 kPa	010/121921
3.31 Bar & 21 kPa	010/133121
3.71 Bar & 21 kPa	010/137121
4.40 Bar & 21 kPa	010/144021

Related Parts

Description	Part No.
2½” BSP weld-in socket	600/1000
Tank weld-in flange	176/3150
CNAF/PTFE gasket (adaptor flange)	5005-398
0-7 Bar pressure gauge, brass internal parts	921/07BBSP
0-7 Bar pressure gauge, stainless steel internal parts	920/07BBSP
Flame arrester *Warning	176/2900
Gauzed cowl *Warning	176/6000

Section View

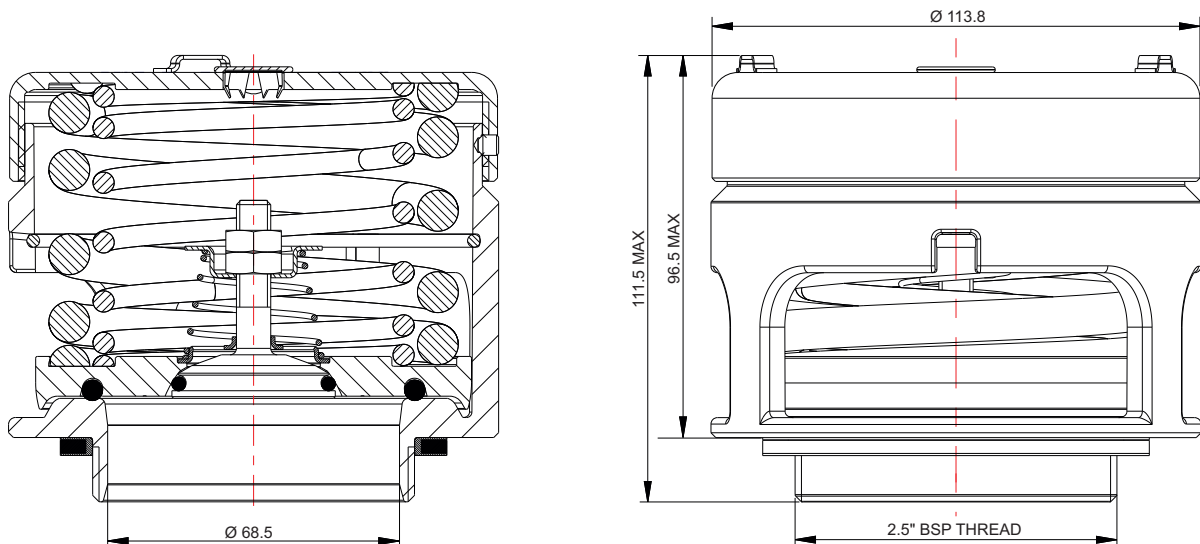



2 1/2" BSP Super Maxi Relief Valve - Pressure/Vacuum

Part No: 010/1XXXXX - Metric Setting

Parts Drawing

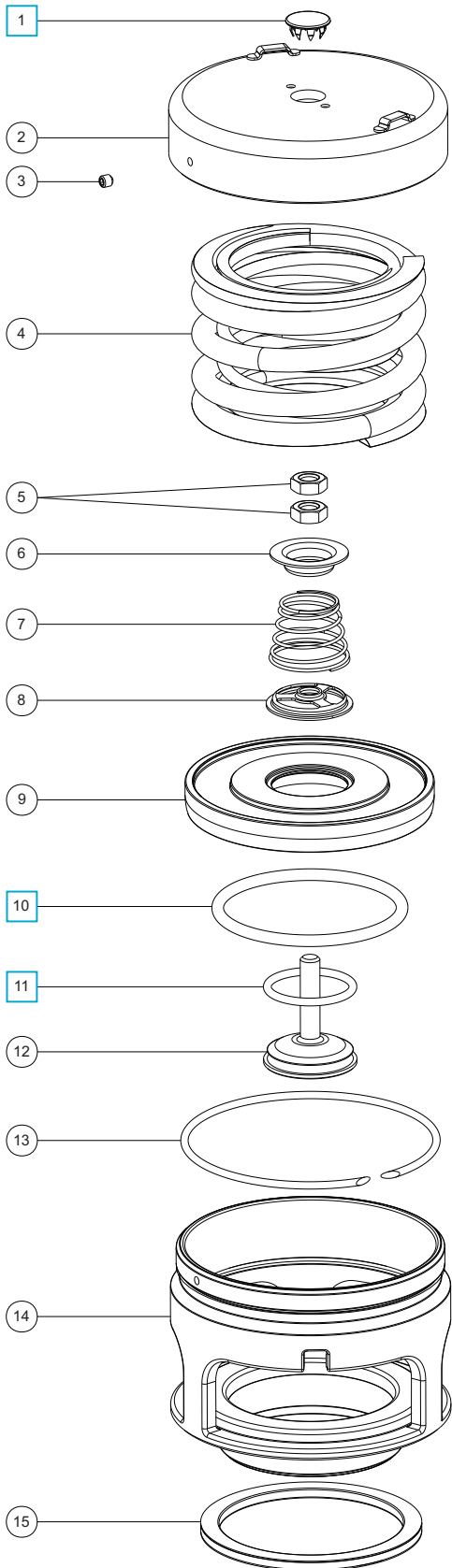

Parts List

Item	Description	Part No.
1	Stainless steel plug	10978 <input type="checkbox"/>
2	Cap *Note	1760/0005XX
3	Anti-tamper screw	5121-001
4	Pressure springs	Refer to Table 1
5	M8 half nut (2)	5112-004
6	Vacuum spring pad	1860/0005
7	Vacuum spring	Refer to Table 2
8	Spring pad	10986/3
9	Pressure plate *Note	1860/005XXX
10	Fortyt pressure O ring	5005-101 <input type="checkbox"/>
11	Fortyt vacuum O ring	5005-108H <input type="checkbox"/>
12	Vacuum poppet	10983V/3
13	Retaining ring clip	5120-067
14	Body	1860/0100
15	Rubber/PTFE envelope seal	5005-046

NOTE: The valve specification changes the Part No.

Table 1

Std. Pressure Settings	Pressure Spring Part No.
2.19 Bar	6104-0252
3.31 Bar	6104-0112 & 6104-0252
3.71 Bar	6104-0422 (Pair)
4.40 Bar	6104-0485 (Pair)

Pressure springs are available from 0.15 Bar to 5.15 Bar

Table 2

Std. Vacuum Setting	Vacuum Spring Part No.
21 kPa	7104-012

Vacuum springs are available from 1 kPa to 88 kPa

Seal Kit

Description	Part No.
All parts marked <input type="checkbox"/> in the Parts List	000/1PVSK



2½" BSP High Pressure Super Maxi Relief Valve

Part No: 0R0/1XXXX00 - Metric Setting



Specification

Nominal size

DN65

Tank connection

2½" BSP

Set pressure

From 5.2 Bar to 11.1 Bar

Materials

Contact parts: 316 stainless steel

Pressure O ring: Fortyt

Tank seal: Rubber/PTFE envelope

Alternatives are available, refer to the Design Options page

Design Conditions

Weight:	3.75 Kg
Design Pressure (MAWP):	11 Bar
Test Pressure:	22.3 Bar
Design Temperature Min:	-55°C
Design Temperature Max:	200°C

NOTE: The working temperature of the pressure O ring can change the design temperature limits. The Design Conditions and Section View dimensions are for the specified part number only.

Design Approval

Lloyds Register of Shipping

WARNING: If you install an approved relief valve accessory item, e.g. a flame arrester, cowl, burst disc or baffle, it will decrease the air flow capacity of the relief valve. Thus, you must calculate again to make sure that the decreased air flow capacity will give sufficient protection to your vessel/system. Refer to Fort Vale for more information.

Range

Description	Part No.
Pressure only valve	0R0/1XXXX00
Pressure/vacuum valve	0R0/1XXXXXX

Related Parts

Description	Part No.
2½" BSP weld-in socket	600/1000
2½" BSP burst disc adaptor assembly	176/7020
Tank weld-in flange	176/3150
Burst disc adaptor flange	176/7001
65mm burst disc - refer to Fort Vale	862/XXXX
CNAF/PTFE gasket (adaptor flange)	5005-398
0-20 Bar pressure gauge, brass internal parts	921/20BBSP
Flame arrester *Warning	176/2900
Gauzed cowl *Warning	176/6000

Section View

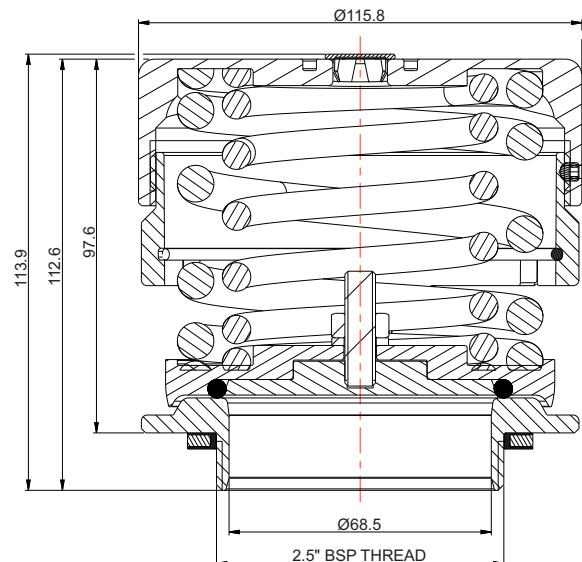
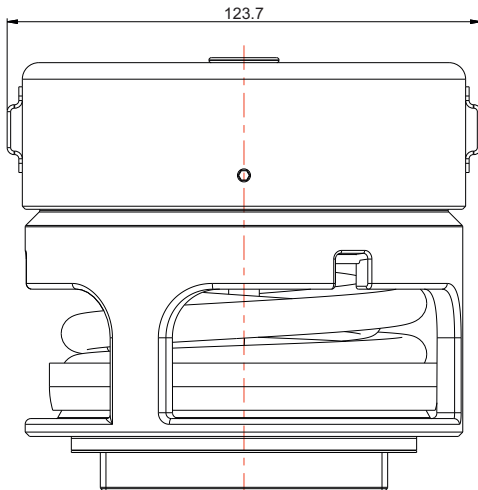



2 1/2" BSP High Pressure Super Maxi Relief Valve

Part No: 0R0/1XXXX00 - Metric Setting

Parts Drawing

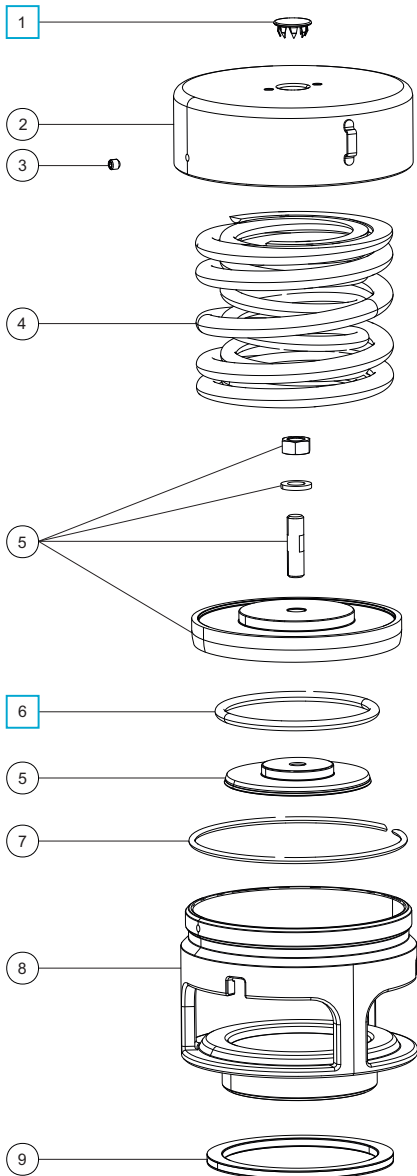

Parts List

Item	Description	Part No.
1	Stainless steel plug	10978 <input type="checkbox"/>
2	Cap *Note	1X60/XXXXXX
3	Anti-tamper screw	5121-001
4	Pressure springs *Note	6104-XXXXX
5	Pressure plate assembly *Note	1860/X088XX
6	Fortyt pressure O ring	BVTS335 <input type="checkbox"/>
7	Retaining ring clip	5120-067
8	Body	1860/0100
9	Rubber/PTFE envelope seal	5005-046

NOTE: The valve specification changes the Part No.

Seal Kit

Description	Part No.
All parts marked <input type="checkbox"/> in the Parts List	018/1PSK



2½” BSP Extended Super Maxi Relief Valve - Pressure Only

Part No: 018/1XXXX00 - Metric Setting



Specification

Nominal size
DN65

Tank connection
2½” BSP

Set pressure
From 11.2 Bar to 16.0 Bar

Materials
Contact parts: 316 stainless steel
Pressure O ring: Fortyt
Tank seal: Rubber/PTFE envelope

Alternatives are available, refer to the Design Options page

Design Conditions

Weight: 5.3 Kg
Design Pressure (MAWP): 16 Bar
Test Pressure: 32.1 Bar
Design Temperature Min: -55°C
Design Temperature Max: 200°C

NOTE: The working temperature of the pressure O ring can change the design temperature limits. The Design Conditions and Section View dimensions are for the specified part number only.

Design Approval

Lloyds Register of Shipping

WARNING: If you install an approved relief valve accessory item, e.g. a flame arrester, cowl, burst disc or baffle, it will decrease the air flow capacity of the relief valve. Thus, you must calculate again to make sure that the decreased air flow capacity will give sufficient protection to your vessel/system. Refer to Fort Vale for more information.

Related Parts

Description	Part No.
2½” BSP weld-in socket	600/1000
2½” BSP burst disc adaptor assembly	176/7020
Tank weld-in flange	176/3150
Burst disc adaptor flange	176/7001
65mm burst disc - refer to Fort Vale	862/XXXX
CNAF/PTFE gasket (adaptor flange)	5005-398
0-20 Bar pressure gauge, brass internal parts	921/20BBSP
Flame arrester *Warning	176/2900
Gauzed cowl *Warning	176/6000

Section View

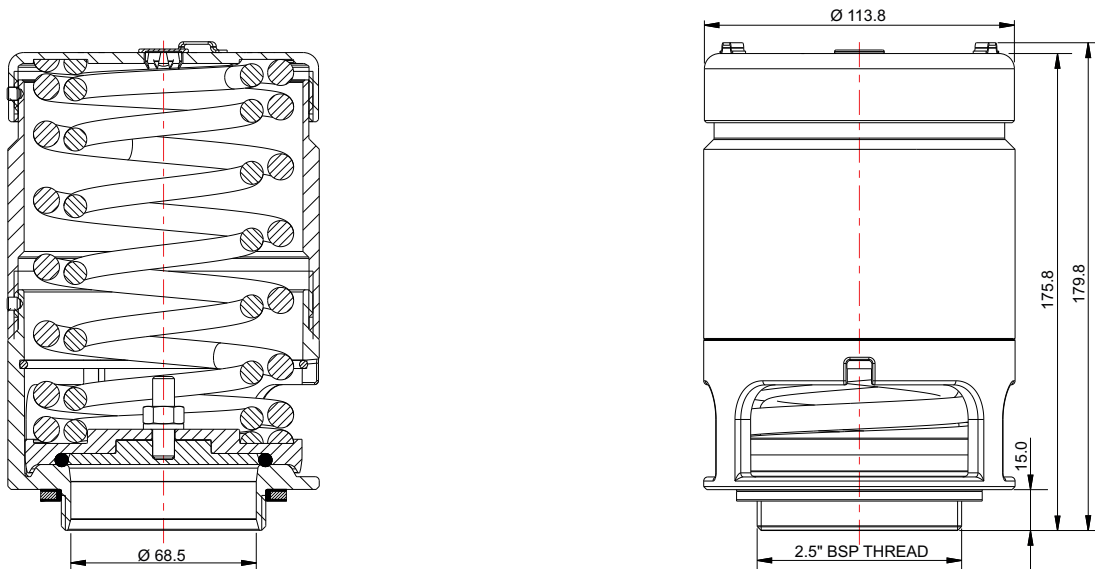



2 1/2" BSP Extended Super Maxi Relief Valve - Pressure Only

Part No: 018/1XXXX00 - Metric Setting

Parts Drawing

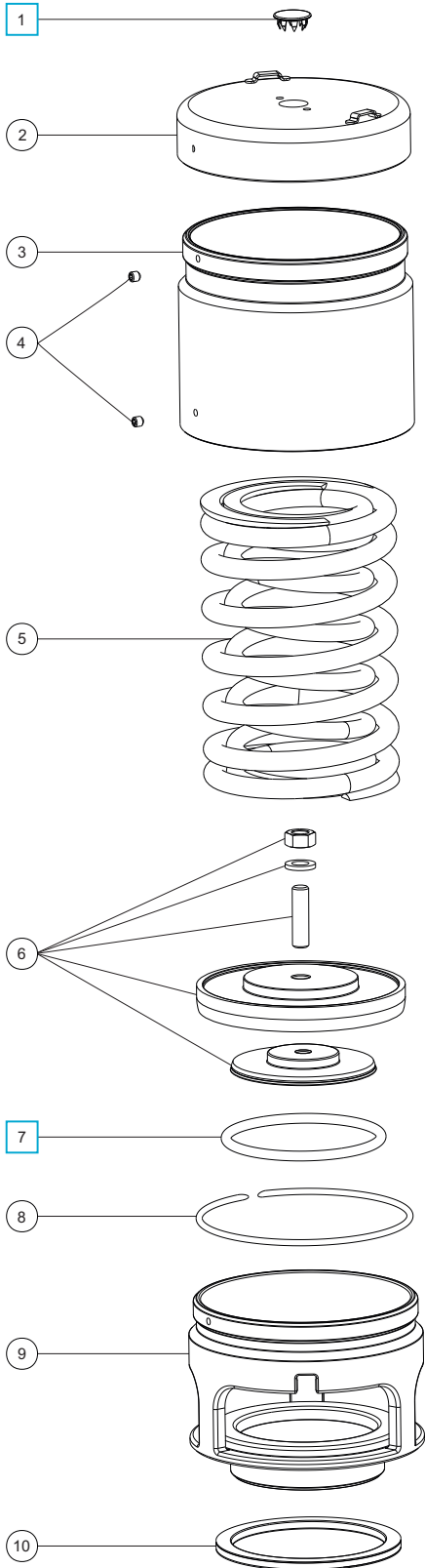

Parts List

Item	Description	Part No.
1	Stainless steel plug	10978 <input type="checkbox"/>
2	Top cap *Note	1760/0005XX
3	Extension tube	1860/0035
4	Anti-tamper screw (2)	5121-001
5	Spring pair *Note	6104-XXXX
6	Pressure plate *Note	1860X088XXX
7	Fortyt pressure O ring	BVTS335 <input type="checkbox"/>
8	Retaining ring clip	5120-067
9	Body	1860/0100
10	Rubber/PTFE envelope seal	5005-046

NOTE: The valve specification changes the Part No.

Seal Kit

Description	Part No.
All parts marked <input type="checkbox"/> in the Parts List	018/1PSK



65mm Flanged Super Maxi Relief Valve - Pressure Only

Part No: 013/1XXX006SL - Metric Setting



Specification

Nominal size

DN65

Tank connection

Flanged: 4 x 18mm slots equi-spaced on a 145.0/152.4 min/max PCD. 1/4" BSP gauge connection

Set pressure

From 0.15 Bar to 4.8 Bar

Materials

Contact parts: 316 stainless steel

Pressure O ring: Fortyt

Alternatives are available, refer to the Design Options page

Design Conditions

Weight:	5.8 Kg
Design Pressure (MAWP):	5.2 Bar
Test Pressure:	10.1 Bar
Design Temperature Min:	-55°C
Design Temperature Max:	200°C

NOTE: The working temperature of the pressure O ring can change the design temperature limits. The Design Conditions and Section View dimensions are for the specified part number only.

Design Codes

Design Approval by Lloyds Register of Shipping

WARNING: If you install an approved relief valve accessory item, e.g. a flame arrester, cowl, burst disc or baffle, it will decrease the air flow capacity of the relief valve. Thus, you must calculate again to make sure that the decreased air flow capacity will give sufficient protection to your vessel/system. Please refer to Fort Vale for more information.

Range

Description	Part No.
Standard valve	013/1XXX006SL
Body with gauge protection bar	013/1XXX006SLGP

Related Parts

Description	Part No.
0-7 Bar pressure gauge, brass internal parts	921/07BBSP
0-7 Bar pressure gauge, stainless steel internal parts	920/07BBSP
Flame arrester *Warning	176/2900
M16 stud kit: 150 & 152.4 PCD	311/3700
M16 cap screw bolt kit: 145 & 146 PCD	311/3785

Section View

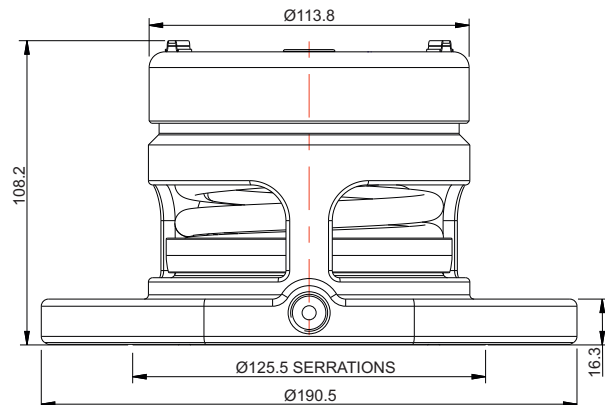
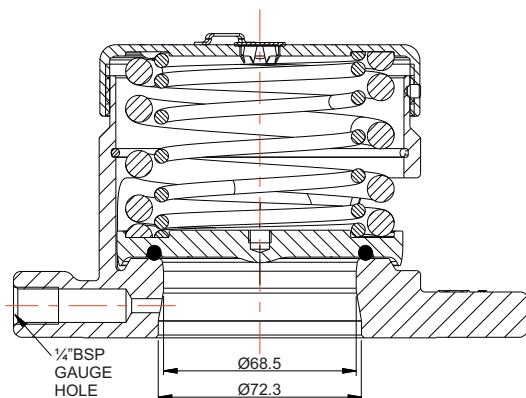



65mm Flanged Super Maxi Relief Valve - Pressure Only

Part No: 013/1XXX006SL - Metric Setting

Parts Drawing

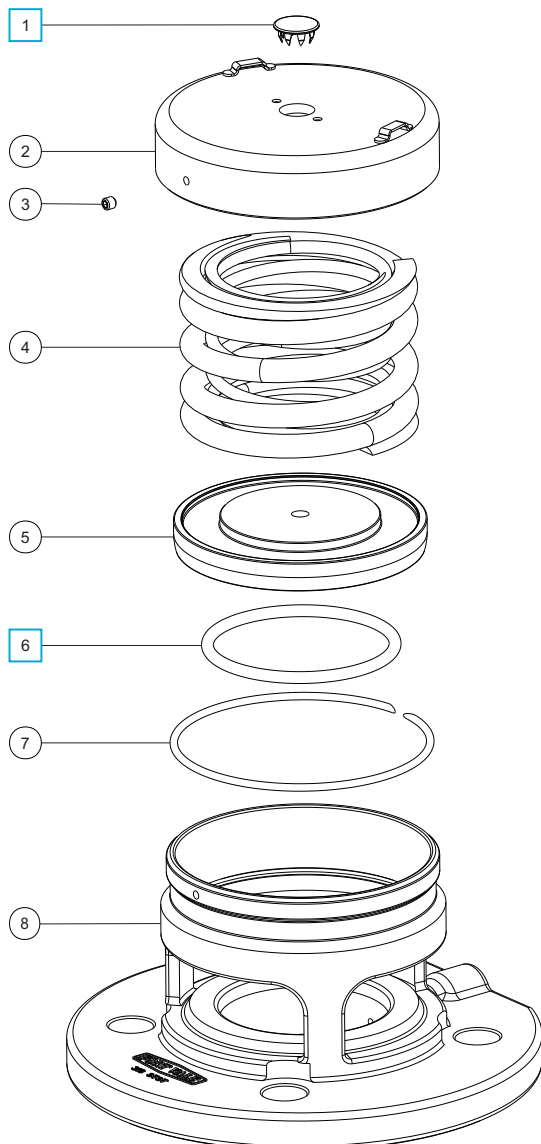

Parts List

Item	Description	Part No.
1	Stainless steel plug	10978 <input type="checkbox"/>
2	Cap	1760/000565
3	Anti-tamper screw	5121-001
4	Pressure spring	Refer to Table 1
5	Pressure plate *Note	1860/005X65
6	Fortyt pressure O ring	5005-101 <input type="checkbox"/>
7	Retaining ring clip	5120-067
8	Body	1860/06SL

NOTE: The valve specification changes the Part No.

Table 1

Std. Pressure Settings	Pressure Spring Part No.
2.19 Bar	6104-0252
3.31 Bar	6104-0112 & 6104-0252
3.71 Bar	6104-0422 (Pair)
4.40 Bar	6104-0485 (Pair)

Pressure springs are available from 0.15 Bar to 4.8 Bar

Seal Kit

Description	Part No.
All parts marked <input type="checkbox"/> in the Parts List	000/1PSK



65mm Flanged Super Maxi Relief Valve - Pressure/Vacuum

Part No: 013/1XXXXX6SL - Metric Setting



Specification

Nominal size

DN65

Tank connection

Flanged: 4 x 18mm slots equi-spaced on a 145.0/152.4 min/max PCD. 1/4" BSP gauge connection

Set pressure

From 0.15 Bar to 4.8 Bar

Set vacuum

From 2 kPa to 88 kPa

Materials

Contact parts: 316 stainless steel

Pressure O ring: Fortyt

Alternatives are available, refer to the Design Options page

Design Conditions

Weight:	6.9 Kg
Design Pressure (MAWP):	5.2 Bar
Test Pressure:	10.2 Bar
Design Temperature Min:	-55°C
Design Temperature Max:	200°C

NOTE: The working temperature of the pressure and vacuum O rings can change the design temperature limits. The Design Conditions and Section View dimensions are for the specified part number only.

Design Codes

Design Approval by Lloyds Register of Shipping

WARNING: If you install an approved relief valve accessory item, e.g. a flame arrester, cowl, burst disc or baffle, it will decrease the air flow capacity of the relief valve. Thus, you must calculate again to make sure that the decreased air flow capacity will give sufficient protection to your vessel/system. Please refer to Fort Vale for more information.

Range

Description	Part No.
Standard valve	013/1XXXXX6SL

Related Parts

Description	Part No.
0-7 Bar pressure gauge, brass internal parts	921/07BBSP
0-7 Bar pressure gauge, stainless steel internal parts	920/07BBSP
Flame arrester *Warning	176/2900
M16 stud kit: 150 & 152.4 PCD	311/3700
M16 cap screw bolt kit: 145 & 146 PCD	311/3785

Section View

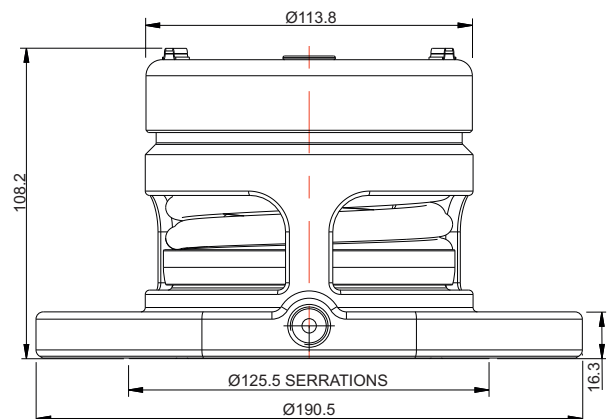
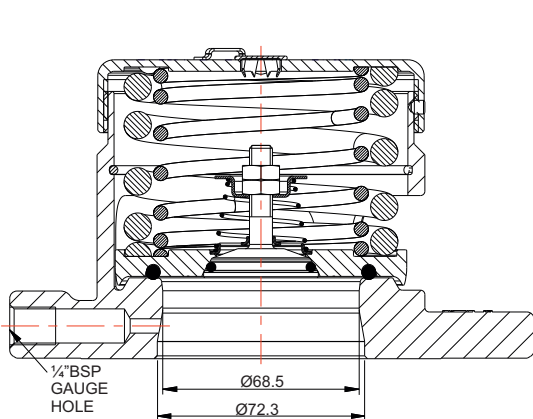



65mm Flanged Super Maxi Relief Valve - Pressure/Vacuum

Part No: 013/1XXXXX6SL - Metric Setting

Parts Drawing

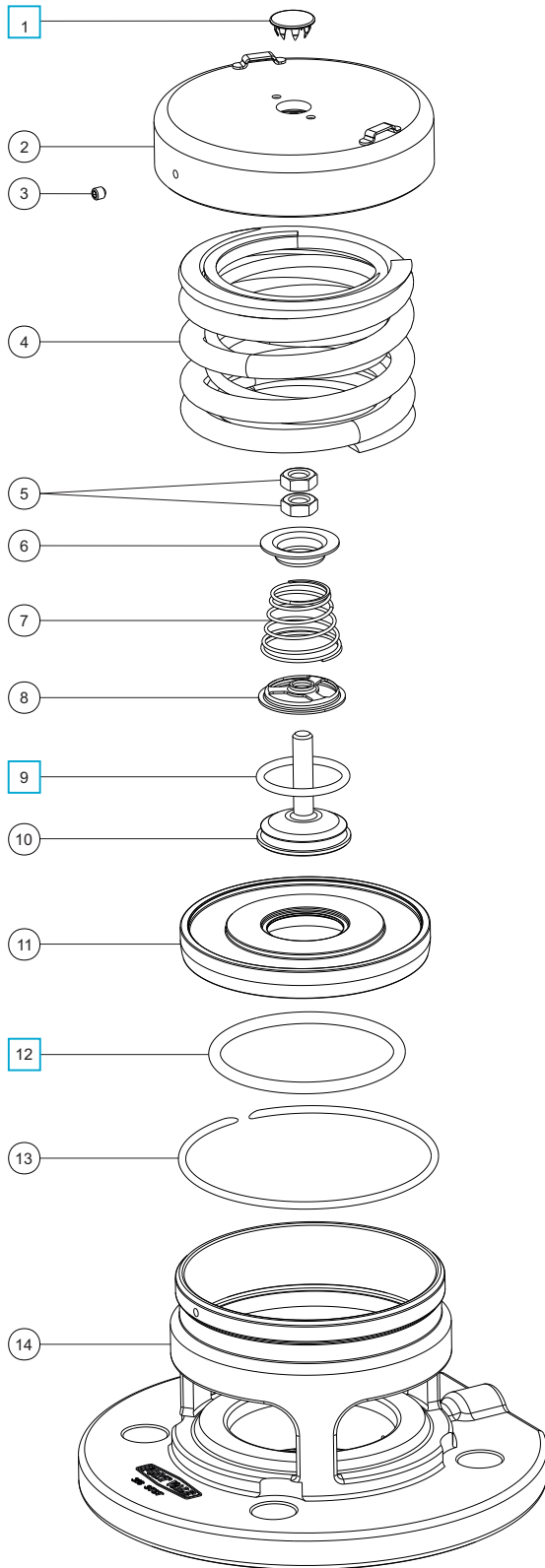

Parts List

Item	Description	Part No.
1	Stainless steel plug	10978 <input type="checkbox"/>
2	Cap *Note	1760/0005XX
3	Anti-tamper screw	5121-001
4	Pressure spring	Refer to Table 1
5	M8 nut (2)	5112-004
6	Vacuum spring pad	1860/0005
7	Vacuum spring	Refer to Table 2
8	Spring pad	10986/3
9	Fortyt vacuum O ring	5005-108H <input type="checkbox"/>
10	Vacuum poppet	10983V/3
11	Pressure plate *Note	1860/005XXX
12	Fortyt pressure O ring	5005-101 <input type="checkbox"/>
13	Retaining ring clip	5120-067
14	Body	1860/06SL

NOTE: The valve specification changes the Part No.

Table 1

Std. Pressure Settings	Pressure Spring Part No.
2.19 Bar	6104-0252
3.31 Bar	6104-0112 & 6104-0252
3.71 Bar	6104-0422 (Pair)
4.40 Bar	6104-0485 (Pair)

Pressure springs are available from 0.15 Bar to 4.8 Bar

Table 2

Std. Vacuum Setting	Vacuum Spring Part No.
10 kPa	7104-006
21 kPa	7104-012

Vacuum springs are available from 1 kPa to 88 kPa

Seal Kit

Description	Part No.
All parts marked <input type="checkbox"/> in the Parts List	000/1PVSX



65mm Flanged Super Maxi Relief Valve - Pressure Only

Part No: 0R3/1XXXX06SL - Metric Setting



Specification

Nominal size
DN65

Tank connection

Flanged: 4 x 18mm slots equi-spaced on a 145.0/152.4 min/max PCD. 1/4" BSP gauge connection

Set pressure

From 5.2 Bar to 11.4 Bar

Materials

Contact parts: 316 stainless steel
Pressure O ring: Fortyt

Alternatives are available, refer to the Design Options page

Design Conditions

Weight:	6.6 Kg
Design Pressure (MAWP):	11.4 Bar
Test Pressure:	17.1 Bar
Design Temperature Min:	-55°C
Design Temperature Max:	200°C

NOTE: The working temperature of the pressure O ring can change the design temperature limits. The Design Conditions and Section View dimensions are for the specified part number only.

Design Codes

Design Approval by Lloyds Register of Shipping

WARNING: If you install an approved relief valve accessory item, e.g. a flame arrester, cowl, burst disc or baffle, it will decrease the air flow capacity of the relief valve. Thus, you must calculate again to make sure that the decreased air flow capacity will give sufficient protection to your vessel/system. Please refer to Fort Vale for more information.

Related Parts

Description	Part No.
0-20 Bar pressure gauge, brass internal parts	921/20BBSP
65mm burst disc - refer to Fort Vale	862/XXXX
Flame arrester *Warning	176/2900
M16 stud kit: 150 & 152.4 PCD	311/3700
M16 cap screw bolt kit: 145 & 146 PCD	311/3785

Section View

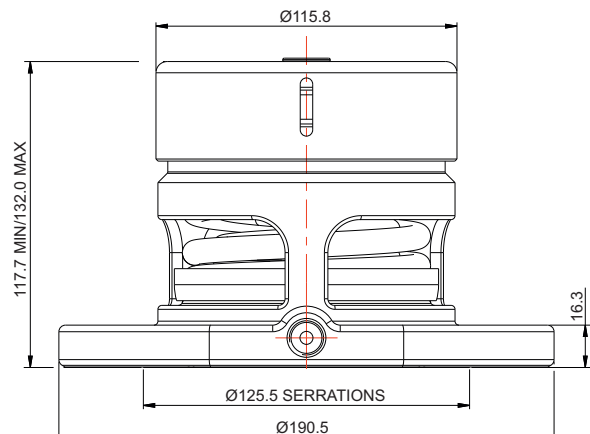
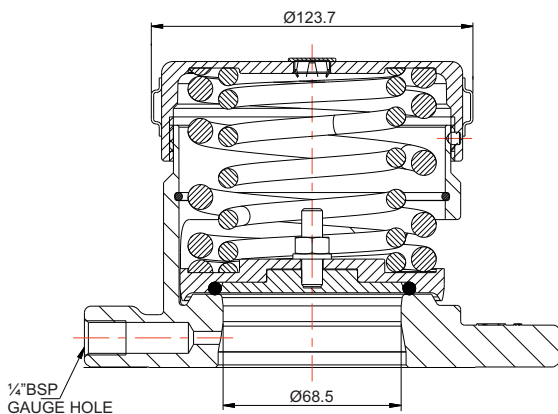



65mm Flanged Super Maxi Relief Valve - Pressure Only

Part No: 0R3/1XXXX06SL - Metric Setting

Parts Drawing

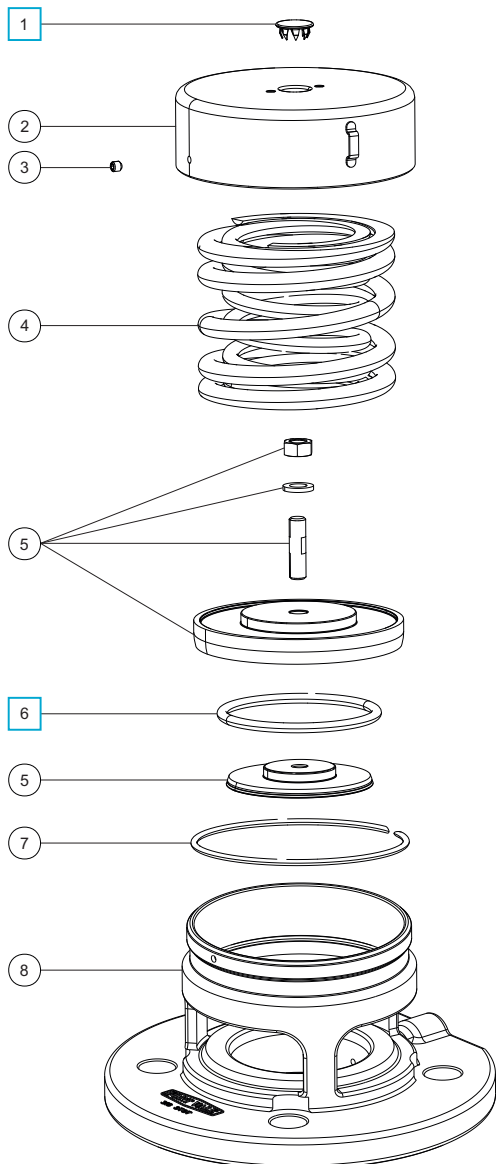

Parts List

Item	Description	Part No.
1	Stainless steel plug	10978 <input type="checkbox"/>
2	Cap *Note	1X60/XXXXXX
3	Anti-tamper screw	5121-001
4	Pressure springs *Note	6104-XXXXXX
5	Pressure plate assembly *Note	1860/X088XXX
6	Fortyt pressure O ring	BVTS335 <input type="checkbox"/>
7	Retaining ring clip	5120-067
8	Body *Note	1860/06XX

NOTE: The valve specification changes the Part No.

Seal Kit

Description	Part No.
All parts marked <input type="checkbox"/> in the Parts List	018/1PSK



65mm Extended Super Maxi Relief Valve - Pressure Only

Part No: 019/1XXXX0654 - Metric Setting



Specification

Nominal size

DN65

Tank connection

Flanged: 4 x 18mm holes on a 139.7mm PCD. 1/4" BSP gauge connection

Set pressure

From 11.2 Bar to 16.0 Bar

Materials

Contact parts: 316 stainless steel

Pressure O ring: Fortyt

Alternatives are available, refer to the Design Options page

Design Conditions

Weight:	8.26 Kg
Design Pressure (MAWP):	16.0 Bar
Test Pressure:	32.1 Bar
Design Temperature Min:	-55°C
Design Temperature Max:	200°C

NOTE: The working temperature of the pressure O ring can change the design temperature limits. The Design Conditions and Section View dimensions are for the specified part number only.

Design Approval

Lloyds Register of Shipping

WARNING: If you install an approved relief valve accessory item, e.g. a flame arrester, cowl, burst disc or baffle, it will decrease the air flow capacity of the relief valve. Thus, you must calculate again to make sure that the decreased air flow capacity will give sufficient protection to your vessel/system. Refer to Fort Vale for more information.

Related Parts

Description	Part No.
Weld-in flange	176/3035
CNAF/PTFE envelope gasket	5005-897
M16 stud kit	311/3700
65mm burst disc - refer to Fort Vale	862/XXXX
0-20 Bar pressure gauge, brass internal parts	921/20BBSP
Flame arrester *Warning	176/2900

Section View

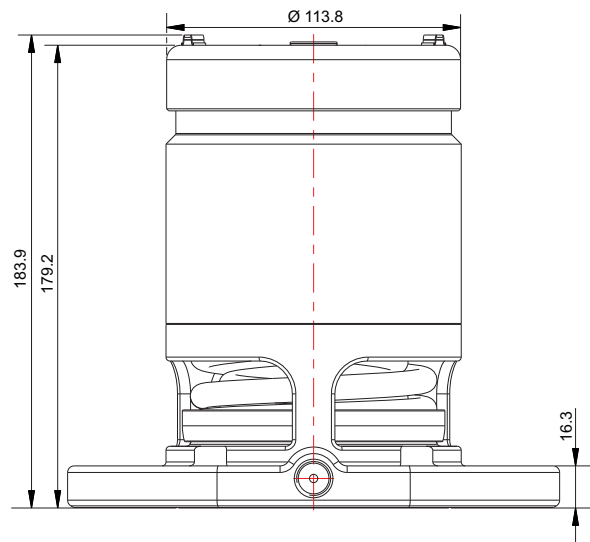
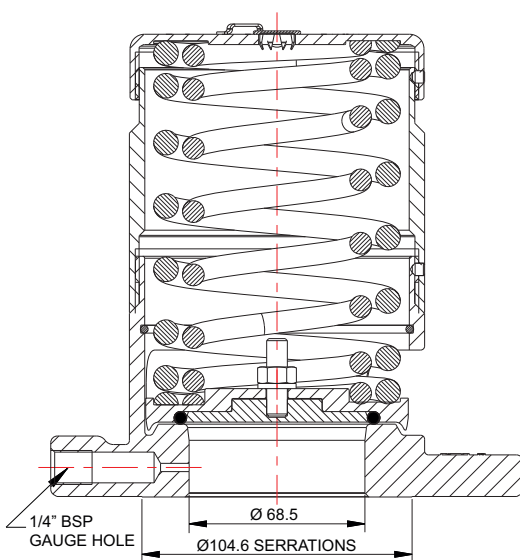



65mm Extended Super Maxi Relief Valve - Pressure Only

Part No: 019/1XXXX0654 - Metric Setting

Parts Drawing

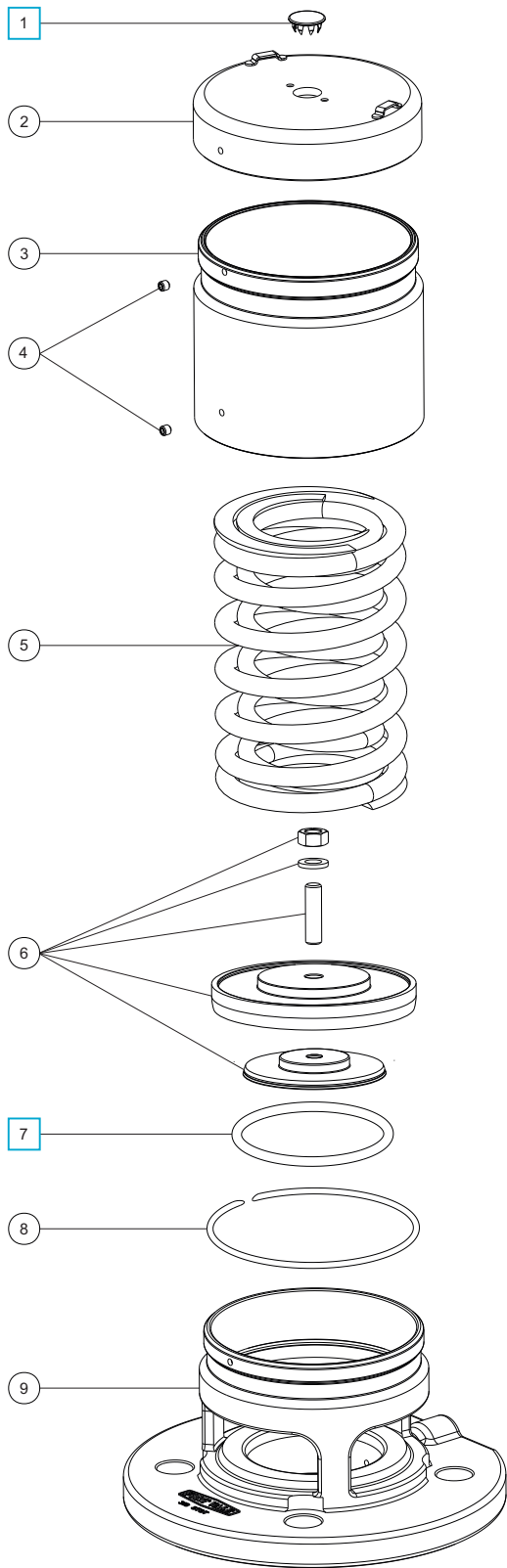

Parts List

Item	Description	Part No.
1	Stainless steel plug	10978 <input type="checkbox"/>
2	Top cap *Note	1760/0005XX
3	Extension tube	1860/0035
4	Anti-tamper screw (2)	5121-001
5	Spring pair *Note	6104-XXXX
6	Pressure plate *Note	1860/X088XXX
7	Fortyt pressure O ring	BVTS335 <input type="checkbox"/>
8	Retaining ring clip	5120-067
9	Body	1860/0654E

NOTE: The valve specification changes the Part No.

Seal Kit

Description	Part No.
All parts marked <input type="checkbox"/> in the Parts List	018/1PSK



82.5mm Flanged Hyper Maxi Relief Valve - Pressure Only

Part No: 043/1XXX0082S - Metric Setting



Specification

Nominal size
DN80

Tank connection

Flanged: 4 slots equi-spaced on a 145.0/152.4 min/max PCD. 1/4" BSP gauge connection.

Refer to Flange Drilling & Accessory Parts

Set pressure

From 0.15 Bar to 5.15 Bar

Materials

Contact parts: 316 stainless steel

Pressure O ring: Fortyt

Alternatives are available, refer to the Design Options page

Design Conditions

Weight:	5.8 Kg
Design Pressure (MAWP):	5.2 Bar
Test Pressure:	10.2 Bar
Design Temperature Min:	-55°C
Design Temperature Max:	200°C

NOTE: The working temperature of the pressure O ring can change the design temperature limits. The Design Conditions and Section View dimensions are for the specified part number only.

Approval

Design Approval by Lloyds Register of Shipping for valves with a setting of ≥ 1.7 Bar.

WARNING: If you install an approved relief valve accessory item, e.g. a flame arrester, cowl, burst disc or baffle, it will decrease the air flow capacity of the relief valve. Thus, you must calculate again to make sure that the decreased air flow capacity will give sufficient protection to your vessel/system. Please refer to Fort Vale for more information.

Flange Drilling & Accessory Parts

Drilling Spec.	PCD mm	Weld-in flange	Gasket
DIN65 PN10	145.0	176/3250	5005-332
3" Table D	146.1	176/3140	5005-013
DIN80 PN6	150.0	176/3158	5005-334
3" ASA 150	152.4	176/3125	5005-204
Slotted	145.0-152.4	N/A	5005-930

Related Parts

Description	Part No.
0-7 Bar pressure gauge, brass internal parts	921/07BBSP
0-7 Bar pressure gauge, stainless steel internal parts	920/07BBSP
Flame arrester *Warning	176/2920
M16 stud kit: 150 & 152.4 PCD	311/3700
M16 cap screw bolt kit: 145 & 146 PCD	311/3785

Section View

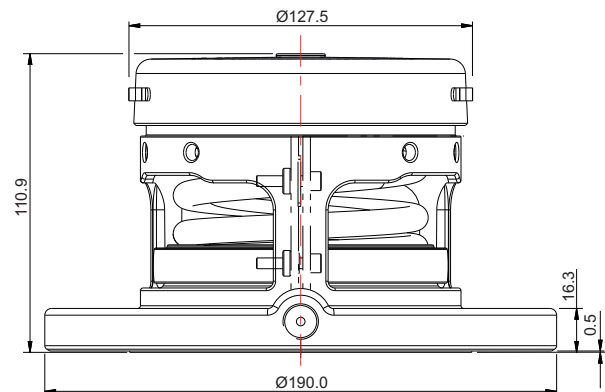
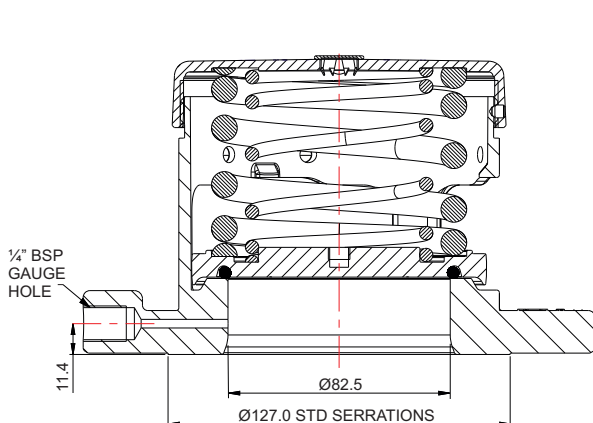



82.5mm Flanged Hyper Maxi Relief Valve - Pressure Only

Part No: 043/1XXX0082S - Metric Setting

Parts Drawing

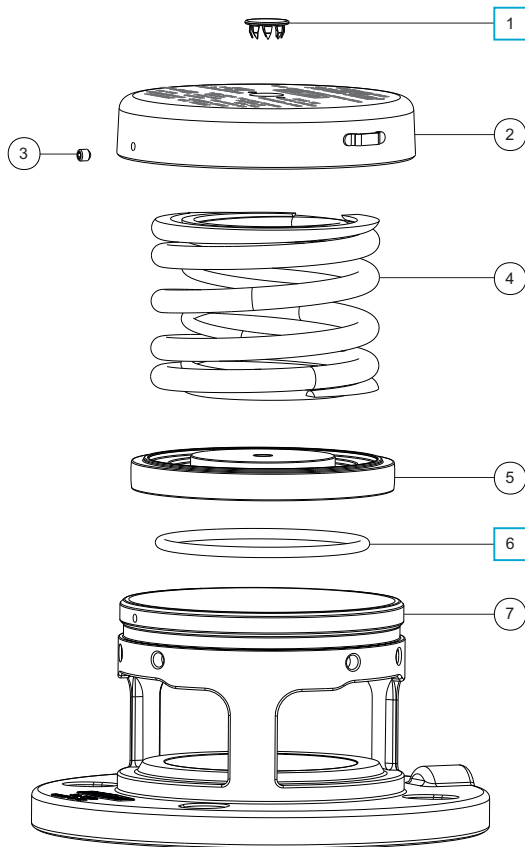

Parts List

Item	Description	Part No.
1	Stainless steel plug	10978 <input type="checkbox"/>
2	Cap *Note	1860/1008XX
3	Anti-tamper screw	5121-001
4	Pressure spring	Refer to Table 1
5	Pressure plate *Note	1860/1070XX
6	Fortyt pressure O ring	ORB337F0 <input type="checkbox"/>
7	Body	1860/19SL

NOTE: The valve specification changes the Part No.

Table 1

Std. Pressure Settings	Pressure Spring Part No.
2.65 Bar	6104-0112 & 6104-0310
3.00 Bar	6104-0155 & 6104-0310
4.40 Bar	6104-0665 (Pair)

Pressure springs are available from 0.15 Bar to 5.15 Bar

Seal Kit

Description	Part No.
All parts marked <input type="checkbox"/> in the Parts List	043/1PSK



82.5mm Flanged Hyper Maxi Relief Valve - Pressure/Vacuum

Part No: 043/1XXXXX82S - Metric Settings



Specification

Nominal size

DN80

Tank connection

Flanged: 4 slots equi-spaced on a 145.0/152.4 min/max PCD. 1/4" BSP gauge connection.

Refer to Flange Drilling & Accessory Parts

Set pressure

From 0.15 Bar to 5.15 Bar

Set vacuum

From 1 kPa to 88 kPa

Materials

Contact parts: 316 stainless steel

Pressure O ring: Fortyt

Vacuum O ring: Fortyt

Alternatives are available, refer to the Design Options page

Design Conditions

Weight:	5.85 Kg
Design Pressure (MAWP):	5.2 Bar
Test Pressure:	10.2 Bar
Design Temperature Min:	-55°C
Design Temperature Max:	200°C

NOTE: The working temperature of the pressure and vacuum O rings can change the design temperature limits. The Design Conditions and Section View dimensions are for the specified part number only.

Approval

Design Approval by Lloyds Register of Shipping for valves with a setting of ≥ 1.7 Bar

WARNING: If you install an approved relief valve accessory item, e.g. a flame arrester, cowl, burst disc or baffle, it will decrease the air flow capacity of the relief valve. Thus, you must calculate again to make sure that the decreased air flow capacity will give sufficient protection to your vessel/system. Please refer to Fort Vale for more information.

Flange Drilling & Accessory Parts

Drilling Spec.	PCD mm	Weld-in flange	Gasket
DIN65 PN10	145.0	176/3250	5005-332
3" Table D	146.1	176/3140	5005-013
DIN80 PN6	150.0	176/3158	5005-334
3" ASA 150	152.4	176/3125	5005-204
Slotted	145.0-152.4	N/A	5005-930

Related Parts

Description	Part No.
0-7 Bar pressure gauge, brass internal parts	921/07BBSP
0-7 Bar pressure gauge, stainless steel internal parts	920/07BBSP
Flame arrester *Warning	176/2920
M16 stud kit: 150 & 152.4 PCD	311/3700
M16 cap screw bolt kit: 145 & 146 PCD	311/3785

Section View

Shown with a flame arrester installed

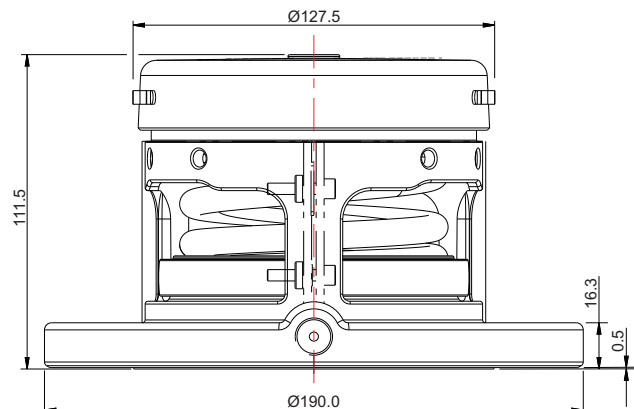
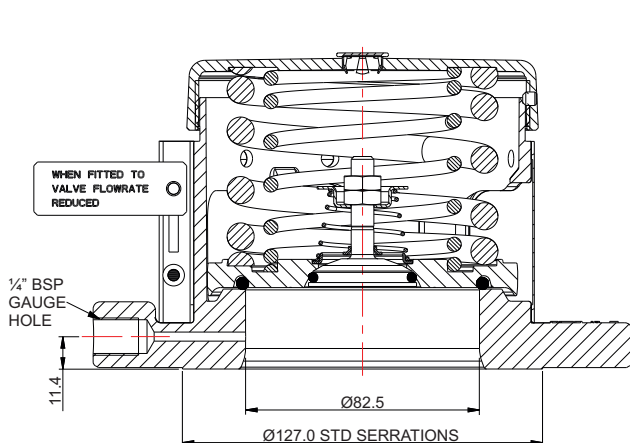



82.5mm Flanged Hyper Maxi Relief Valve - Pressure/Vacuum

Part No: 043/1XXXXX82S - Metric Settings

Parts Drawing

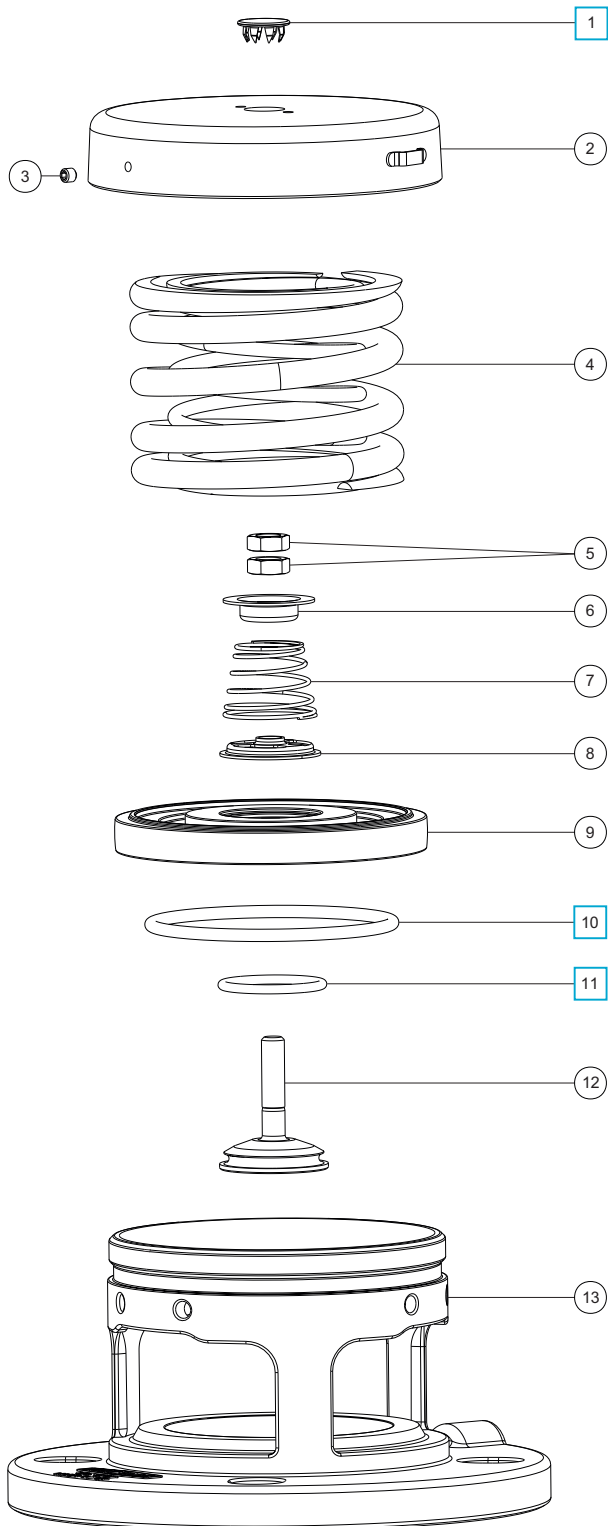

Parts List

Item	Description	Part No.
1	Stainless steel plug	10978
2	Cap *Note	1860/1008XX
3	Anti-tamper screw	5121-001
4	Pressure spring	Refer to Table 1
5	M8 half nut (2)	5112-004
6	Vacuum spring pad	1860/0005
7	Vacuum spring	Refer to Table 2
8	Spring pad	10986/3
9	Pressure plate *Note	1860/1071XX
10	Fortyt pressure O ring	ORB337F0
11	Fortyt vacuum O ring	5005-108H
12	Vacuum poppet	10983V/3
13	Body	1860/19SL

NOTE: The valve specification changes the Part No.

Table 1

Std. Pressure Settings	Pressure Spring Part No.
2.20 Bar	6104-0048 & 6104-0310
2.65 Bar	6104-0085 & 6104-0310
3.30 Bar	6104-0195 & 6104-0310
4.40 Bar	6104-0665 (Pair)

Pressure springs are available from 0.15 Bar to 5.15 Bar

Table 2

Std. Vacuum Setting	Vacuum Spring Part No.
21 kPa	7104-012

Vacuum springs are available from 1 kPa to 88 kPa

Seal Kit

Description	Part No.
All parts marked <input type="checkbox"/> in the Parts List	043/1PVSK



82.5mm Extended Hyper Maxi Relief Valve - Pressure Only

Part No: 049/1XXXX0082S - Metric Setting



Specification

Nominal size
DN80

Tank connection

Flanged: 4 slots equi-spaced on a 145.0/152.4 min/max PCD. 1/4" BSP gauge connection
Refer to Flange Drilling & Accessory Parts

Set pressure

From 5.5 Bar to 14.3 Bar

Materials

Contact parts: 316 stainless steel
Pressure O ring: Fortyt

Alternatives are available, refer to the Design Options page

Design Conditions

Weight: 6.6 to 10.4 Kg **NOTE**

NOTE: The valve specification changes the weight and the design conditions. Please contact Fort Vale for more information.

Approval

Design Approval by Lloyds Register of Shipping

WARNING: If you install an approved relief valve accessory item, e.g. a flame arrester, cowl, burst disc or baffle, it will decrease the air flow capacity of the relief valve. Thus, you must calculate again to make sure that the decreased air flow capacity will give sufficient protection to your vessel/system. Please refer to Fort Vale for more information.

Flange Drilling & Accessory Parts

Drilling Spec.	PCD mm	Weld-in flange	Gasket
DIN65 PN10	145.0	176/3250	5005-332
3" Table D	146.1	176/3140	5005-013
DIN80 PN6	150.0	176/3158	5005-334
3" ASA 150	152.4	176/3125	5005-204

Related Parts

Description	Part No.
0-20 Bar pressure gauge, brass internal parts	921/20BBS
Flame arrester *Warning	176/2920
M16 stud kit: 150 & 152.4 PCD	311/3700
M16 cap screw bolt kit: 145 & 146 PCD	311/3785

Section View

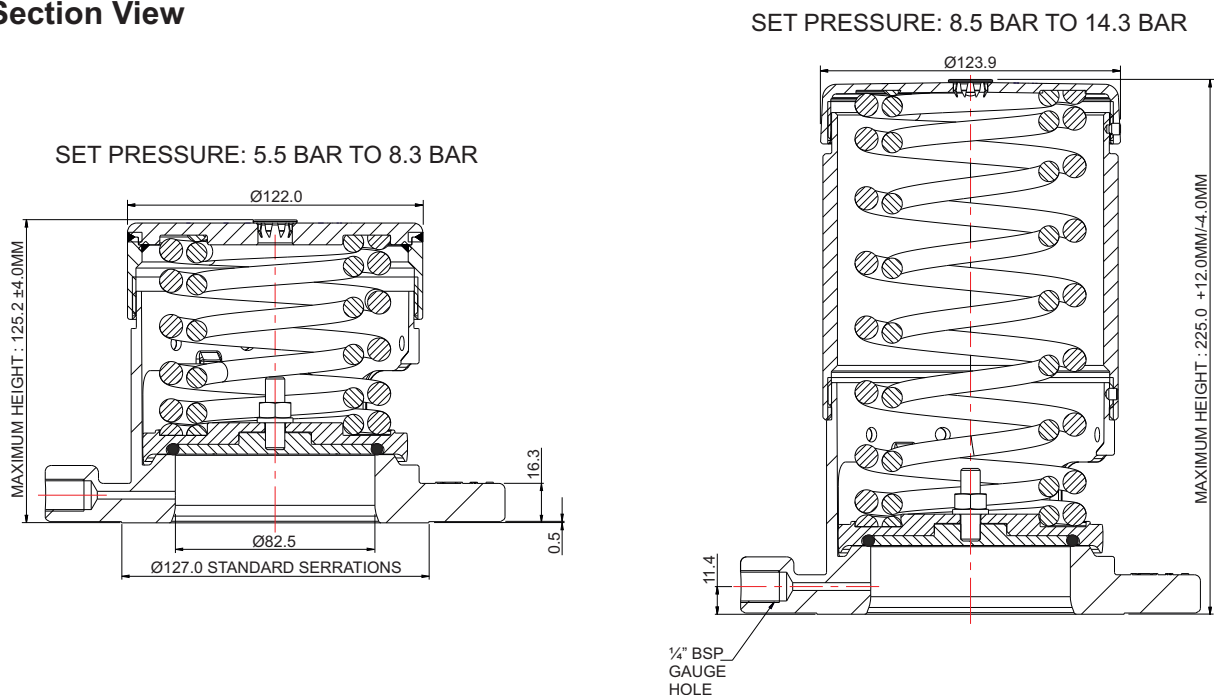



82.5mm Extended Hyper Maxi Relief Valve - Pressure Only

Part No: 049/1XXXX0082S - Metric Setting

Parts Drawing

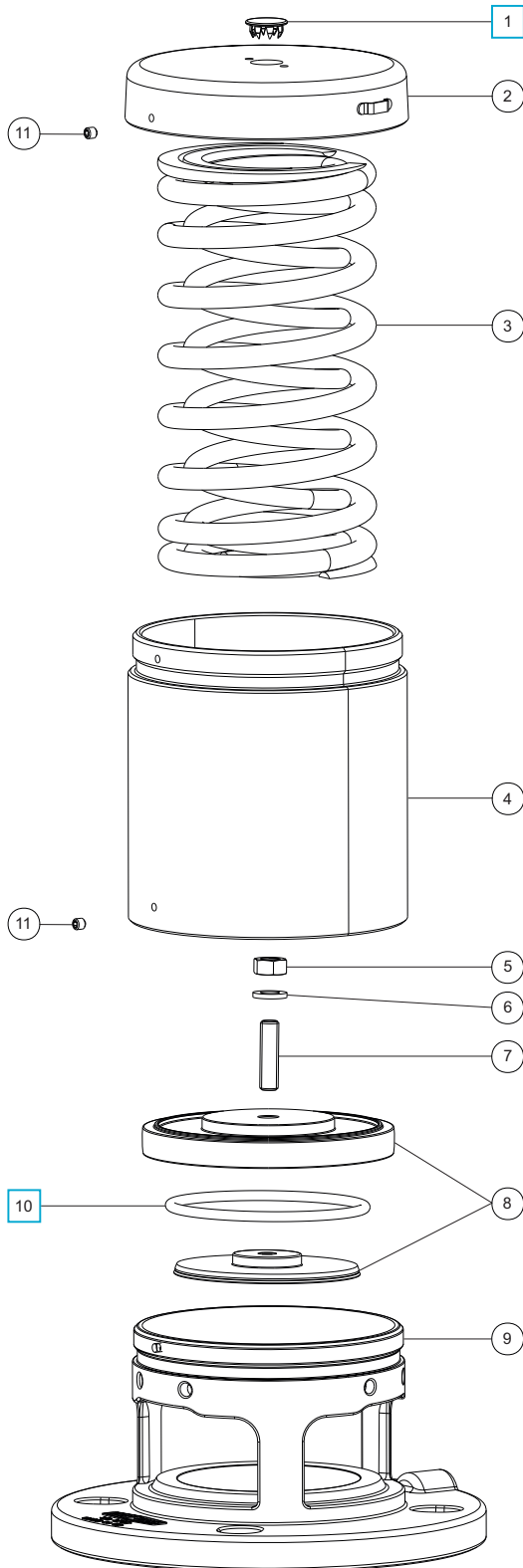

Parts List

Item	Description	Part No.
1	Stainless steel plug	10978 <input type="checkbox"/>
2	Top cap * Note 1	1860/XXXXXX
3	Spring set * Note 1	6104-XXXX
4	Extension tube * Note 2	1860/1025/X
5	Full nut	5112-001
6	Spring washer	5113-003
7	Stud	11426
8	Pressure plate assembly * Note 1	1860/X031XX
9	Body	1860/19SL
10	Fortyt O ring	ORB337F0 <input type="checkbox"/>
11	Anti-tamper screw (2)	5121-001

NOTE 1: The valve specification changes the Part No.

NOTE 2: Valves with a set pressure ≥ 8.5 Bar have an extension tube. The valve specification changes the Part No.

Seal Kit

Description	Part No.
All parts marked <input type="checkbox"/> in the Parts List	043/1PSK



82.5mm Extended Hyper Maxi Relief Valve - Pressure/Vacuum

Part No: 049/1XXXXXX82S - Metric Settings



Specification

Nominal size
DN80

Tank connection

Flanged: 4 slots equi-spaced on a 145.0/152.4 min/max PCD. 1/4" BSP gauge connection
Refer to Flange Drilling & Accessory Parts

Set pressure

From 5.5 Bar to 14.3 Bar

Set vacuum

From 1 kPa to 88 kPa

Materials

Contact parts: 316 stainless steel
Pressure O ring: Fortyt
Vacuum O ring: Fortyt

Alternatives are available, refer to the Design Options page

Design Conditions

Weight: 6.6 to 10.4 Kg **NOTE**

NOTE: The valve specification changes the weight and the design conditions. Please contact Fort Vale for more information.

Approval

Design Approval by Lloyds Register of Shipping

WARNING: If you install an approved relief valve accessory item, e.g. a flame arrester, cowl, burst disc or baffle, it will decrease the air flow capacity of the relief valve. Thus, you must calculate again to make sure that the decreased air flow capacity will give sufficient protection to your vessel/system. Please refer to Fort Vale for more information.

Flange Drilling & Accessory Parts

Drilling Spec.	PCD mm	Weld-in flange	Gasket
DIN65 PN10	145.0	176/3250	5005-332
3" Table D	146.1	176/3140	5005-013
DIN80 PN6	150.0	176/3158	5005-334
3" ASA 150	152.4	176/3125	5005-204

Related Parts

Description	Part No.
0-20 Bar pressure gauge, brass internal parts	921/20BBSP
Flame arrester *Warning	176/2920
M16 stud kit: 150 & 152.4 PCD	311/3700
M16 cap screw bolt kit: 145 & 146 PCD	311/3785

Section View

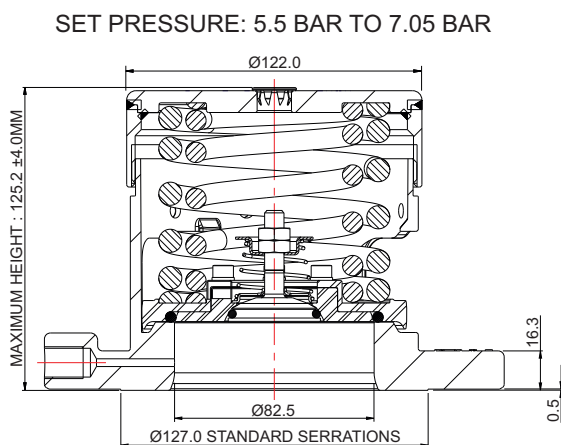

SET PRESSURE: 7.2 BAR TO 14.3 BAR

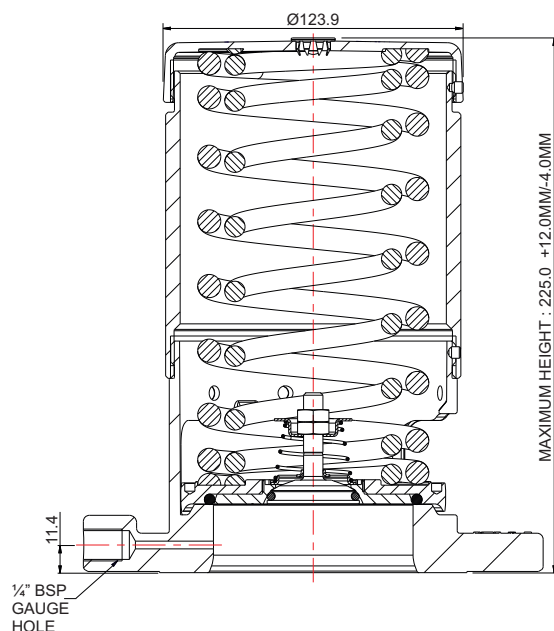



82.5mm Extended Hyper Maxi Relief Valve - Pressure/Vacuum

Part No: 049/1XXXXXX82S - Metric Settings

Parts Drawing

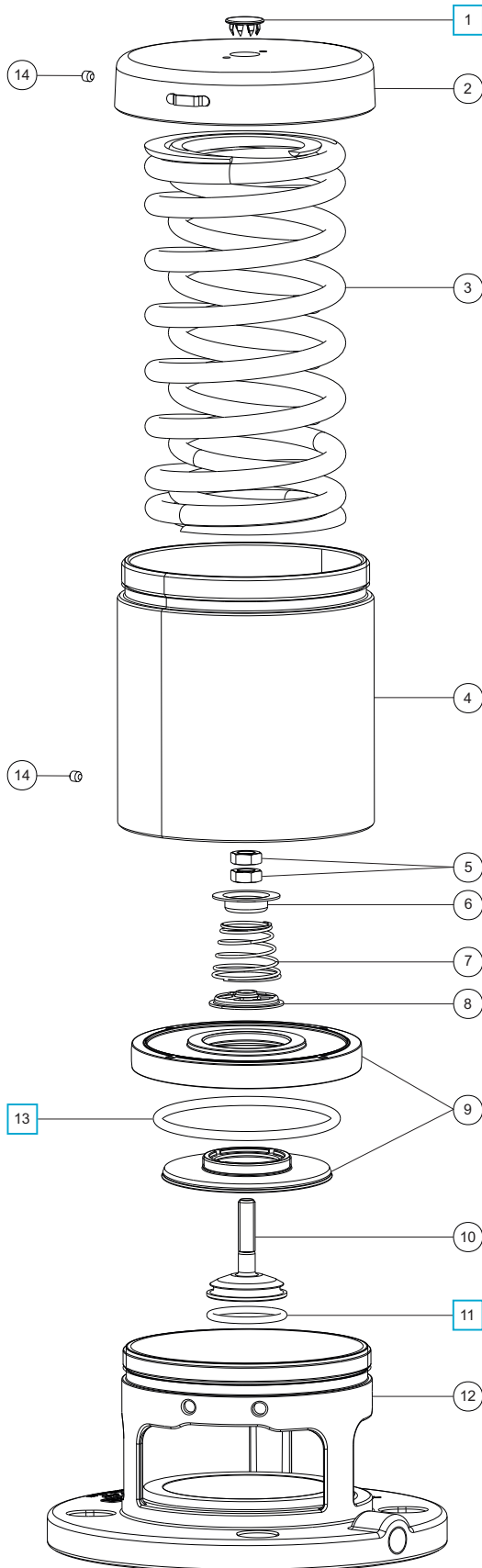

Parts List

Item	Description	Part No.
1	Stainless steel plug	10978 <input type="checkbox"/>
2	Top cap * Note 1	1860/XXXXXX
3	Spring set * Note 1	6104-XXXX
4	Extension tube * Note 2	1860/1025/X
5	M8 half nut (2)	5112-004
6	Vacuum spring pad	1860/0005
7	Vacuum spring	Refer to Table 1
8	Spring pad	10986/3
9	Pressure plate assembly * Note 3	1860/X03XXX
10	Vacuum poppet	10983V/3
11	Fortyt vacuum O ring	5005-108H <input type="checkbox"/>
12	Body * Note 1	1860/19SL
13	Fortyt pressure O ring	ORB337F0 <input type="checkbox"/>
14	Anti-tamper screw (2)	5121-001

NOTE 1: The valve specification changes the Part No.

NOTE 2: Valves with a set pressure ≥ 7.2 Bar have an extension tube. The valve specification changes the Part No.

NOTE 3: A special tool (FIX/A/0010B) is necessary to change the pressure O ring on a valve with a set pressure ≥ 7.2 Bar. Refer to Fort Vale for more information.

Table 1

Std. Vacuum Setting	Vacuum Spring Part No.
21 kPa	7104-012

Vacuum springs are available from 1 kPa to 88 kPa

Seal Kit

Description	Part No.
All parts marked <input type="checkbox"/> in the Parts List	043/1PVSK



Super Maxi & Hyper Maxi Relief Valve Installation Options

Flanged Super Maxi/Hyper Maxi relief valve with burst disc and tank weld-in flange

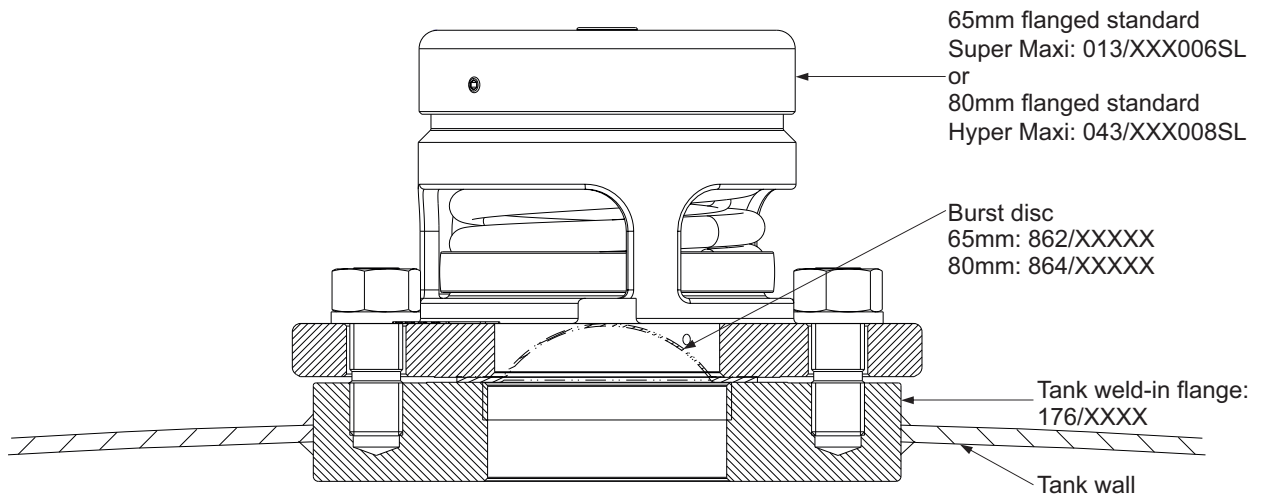

2½" BSP Super Maxi with weatherproof cowl and tank weld-in socket

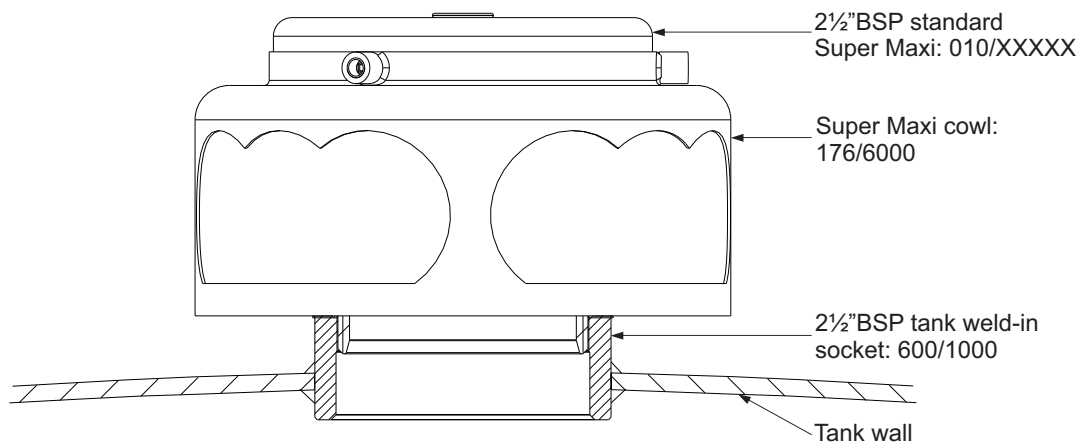

2½" BSP Super Maxi with burst disc, pressure gauge, adaptor flange & weld-in socket

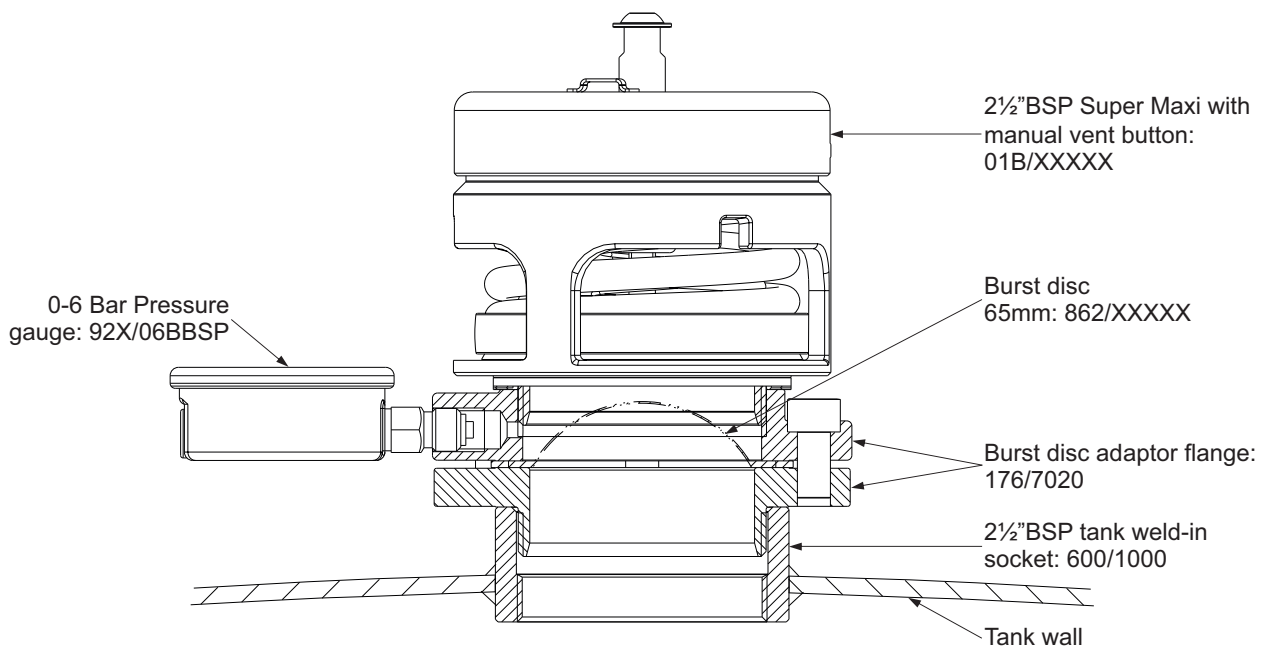



Burst Discs

Accessories & Spare Parts



Specification

Our range of non-fragmenting burst discs is compatible with Fort Vale relief valves and accessories. If you have other manufacturer's equipment, please contact us.

WARNING: A burst disc decreases the air flow capacity of a relief valve. Calculate to make sure that the decreased flow will give sufficient protection to your tank/system. Refer to Fort Vale for more information.

Nominal sizes

65mm XL, 80mm XL, 89mm, 250mm

Other sizes are available, please contact us.

NOTE: 65mm XL/80mm XL discs replace the original 65mm/80mm discs. We do not recommend 65mm/80mm discs with Fort Vale relief valves.

Disc options

Forward Acting: a cross-scored solid metal disc

Forward Composite: a multi-layered disc for burst settings of less than 3.67 Bar

Reverse Acting: compatible with gas service

Materials

65XL/80XL/89mm: PTFE/316 stainless steel/Nickel

250mm: PTFE/316 stainless steel

Other materials are available, refer to next page.

65mm XL Burst Discs

Compatible with general purpose tank containers and road tankers.

Burst Pressure Bar	Burst Temperature °C	Part No.
2.28	20	862/X0228020B
2.41	20	862/X0241020B
2.69	20	862/X0269020B
3.10	20	862/X0310020B
3.67	20	862/X0367020A
4.10	20	862/X0410020A
4.40	20	862/X0440020A
4.84	20	862/X0484020A

NOTE: The specification changes the part no.

80mm XL Burst Discs

Compatible with general purpose tank containers and road tankers.

Burst Pressure Bar	Burst Temperature °C	Part No.
3.67	20	864/X0367020A
4.10	20	864/X0410020A
4.84	20	864/X0484020A

NOTE: The specification changes the part no.

89mm Reverse Acting Burst Discs

Compatible with compressed liquefied gas tank containers.

Burst Pressure Bar	Burst Temperature °C	Part No.
12.10	55	864/X1210055GX
15.00	55	864/X1500055GX
22.00	55	864/X2200055GX
27.50	55	864/X2750055GX
34.50	55	864/X3450055GX

NOTE: The specification changes the part no.

250mm Standard Burst Discs

Compatible with hydrogen peroxide service.

Burst Pressure Bar	Burst Temperature °C	Part No.
4.50	20	865/A0450020AD
4.50	60	865/A0450060AD
6.00	20	865/A0600020AD



Part Number Code: 65mm XL, 80mm XL, 89mm Only
Accessories & Spare Parts

Example: **8 6 X / X 0484 020 X X**

Disc Size

- 862/ 65mm XL
- 864/ 80mm XL or 89mm Reverse Acting

Disc Manufacturer

- A CDC (Continental Disc Corporation)
- B BS&B Safety Systems
- C Schlesinger

Burst Pressure in kPa

- 0484 484 kPa (4.84 Bar)

Burst Temperature in °C

- 020 20°C

Disc Type

- A Forward Acting (ICON)
- B Forward Composite (PC-SERT)
- G Reverse Acting: Gas service

Special Material/Service: Disc Type A & B Only

Note: No number = Standard Material/Service

- 1 PFA Lined
- 2 PTFE Lined
- 3 Tantalum
- 4 Alloy 600
- 5 Oxygen Cleaned
- 6 High Temperature 250°
- 7 Titanium
- 8 Standard 30° Angle
- 9 Monel ®
- A Inconel ® / 316TI
- B Nickel
- C Hastelloy ® C276
- D Standard + Handling Support
- E Monel ® Fluoro Coated

Special Material/Service: Disc Type G Only

Note: No number = Standard Material/Service

- 1 Hastelloy ® / PTFE
- 2 Monel ®
- 3 Tantalum
- 4 Alloy 400
- 5 Alloy 600
- 6 Monel ® 400 / Sigma ® 500



Flame Arresters & Debris Protection for Relief Valves

Accessories & Spare Parts

Flame Arresters



Specification

A relief valve flame arrester attaches around the ports of the relief valve body. It prevents an external flame from being transmitted into the tank on relief valves with a vacuum setting of ≤ 0.21 Bar (6"Hg).

For relief valves with a vacuum setting of > 0.21 Bar (6"Hg), a flame arrester is frequently used to prevent debris from going into the tank through the relief valve.

Nominal sizes

Compatible with 1", 1½" 2½", 65mm and 80mm relief valves

Material

Stainless steel

WARNING: If you install a flame arrester, it will decrease the air flow capacity of the relief valve. Thus, you must calculate to make sure that the decreased air flow capacity of the relief valve and flame arrester will give sufficient protection to your vessel/system. Refer to Fort Vale for more information.

Flame Arresters

Each flame arrester is compatible for the specified relief valve type only. Flame arresters are not interchangeable between relief valve types.

IMPORTANT: Refer to the air flow decrease data for your valve type. (See **WARNING**)

Compatible Relief Valve	Air Flow Decrease	Part No.
1" Minnow	17% to 20%	179/0300
1½" Twinact	See Note	200/5000
2½" Twinact	See Note	130/5000
2½" & 65mm Super Maxi	1%	176/2900
80mm Hyper Maxi	5.4%	176/2920

NOTE: For the air flow decrease data for Twinact relief valves, please contact Fort Vale.

Debris Protection - Gauzed Cowl

Part No: 176/6000



Specification

A gauzed cowl attaches to the 65mm Super Maxi relief valve cap. It is used to prevent debris from going into the tank through the relief valve.

Nominal sizes

Compatible with a 65mm/2½" Super Maxi relief valve only

Material

Stainless steel

CAUTION: If you install a gauzed cowl onto a Super Maxi relief valve, it can decrease the relief valve air flow capacity. Refer to Fort Vale for more information.



DN65 Flanges for Super Maxi Relief Valves

Accessories & Spare Parts

Part No: 176/3150



Section View

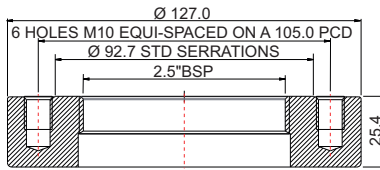

Specification

Flange type

Weld-in flange

Nominal size

DN65 with 2½" BSP thread

Flange drilling

6 x M10 holes equi-spaced on a 104.9mm PCD

Material

316L stainless steel

Compatible valve/part

2½" BSP Super Maxi relief valve

176/7001 adaptor flange with 65mm XL burst disc

Related Parts

Description	Part No.
CNAF/PTFE gasket	5005-398
Bolting kit	176/7021
Adaptor flange	176/7001

Part No: 176/7001



Section View

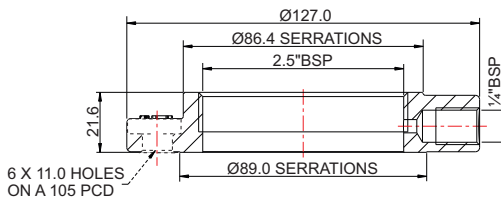

Specification

Flange type

Burst disc adaptor flange

Nominal size

DN65 with 2½" BSP thread

Flange drilling

6 x 11mm holes equi-spaced on a 105mm PCD

Properties

¼" BSP gauge connection

Material

316 stainless steel

Compatible valve/part

2½" BSP Super Maxi relief valve

65mm XL burst disc

Part No: 176/7020



Section View

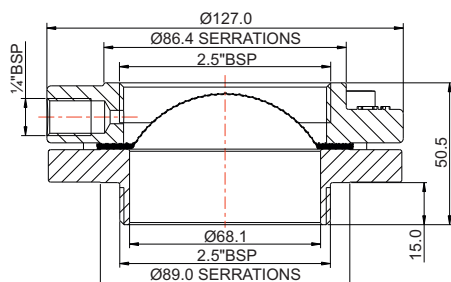

Specification

Flange type

Burst disc adaptor flange assembly

Nominal size

DN65 with 2½" BSP thread

Inlet connection

2½" BSP

Properties

¼" BSP gauge connection, includes M10 washers & bolts
Burst disc not included

Material

316 stainless steel

Compatible valve/part

2½" BSP Super Maxi relief valve

65mm XL burst disc



DN80 Flanges for Super Maxi & Hyper Maxi Relief Valves Accessories & Spare Parts

Part No: 176/3125

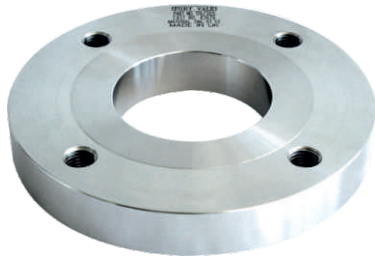

Specification

Flange type
Weld-in flange

Nominal size
DN80

Flange drilling
4 x M16 holes equi-spaced on a 152.4mm PCD

Material
316L stainless steel

Compatible valve/part
80mm Super Maxi & 80mm Hyper Maxi relief valve
80mm XL burst disc

Section View

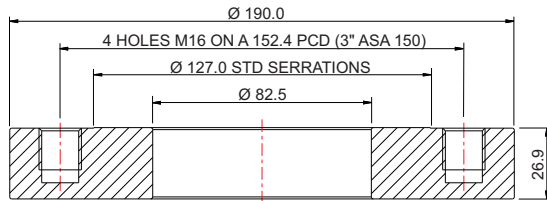

Related Parts

Description	Part No.
CNAF/PTFE gasket	5005-204
Stud kit	311/3700

Part No: 176/3250



Specification

Flange type
Weld-in flange

Nominal size
DN80

Flange drilling
4 x M16 holes equi-spaced on a 145.0mm PCD

Material
316L stainless steel

Compatible valve/part
80mm Super Maxi & 80mm Hyper Maxi relief valve
80mm XL burst disc

Section View

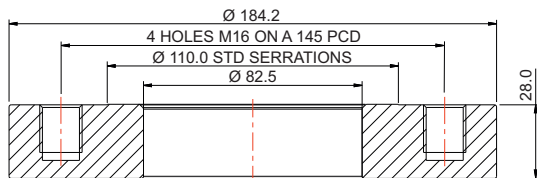

Related Parts

Description	Part No.
CNAF/PTFE gasket	5005-332
Bolt kit	311/3785

Special Flanges

We offer a large range of special weld-in flanges and adaptor flanges, such as recessed, low profile and dual drilled. Please contact us for more information.

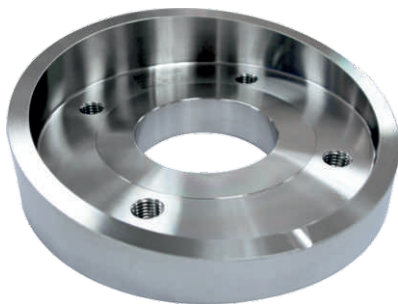



Pressure Gauges

Accessories & Spare Parts

Standard Pressure Gauge



Tell-Tale Pressure Gauge



Specification

We supply standard pressure gauges and tell-tale pressure gauges. Tell-tale pressure gauges have a secondary pointer to indicate if there has been an increase in pressure, even if the pressure subsequently decreases.

All pressure gauges have a 1/4" BSP bottom connection and are glycerine filled.

Pressure range options

0-6 Bar, 0-10 Bar, 0-16 Bar, 0-40 Bar

Material options - internal parts

Brass, stainless steel

Standard Pressure Gauge

Pressure Range Bar	PSI	Internal Parts	Part No.
0-6	0-90	Brass	921/06BBSP
0-6	0-90	St/steel	920/06BBSP
0-10	0-150	Brass	921/10BBSP
0-10	0-150	St/steel	920/10BBSP
0-40	0-580	St/steel	920/40BBSP

Tell-Tale Pressure Gauge

Pressure Range Bar	PSI	Internal Parts	Part No.
0-6	0-90	Brass	921/06TTBBSP
0-6	0-90	St/steel	920/06TTBBSP
0-10	0-150	Brass	921/10TTBBSP
0-10	0-150	St/steel	920/10TTBBSP
0-16	0-230	St/steel	920/16TTBBSP
0-40	0-580	St/steel	920/40TTBBSP



Weld-In Sockets for Relief Valves

Accessories & Spare Parts

Threaded Weld-In Sockets



Specification

Weld-in sockets are heavy-duty and have an oversized thread so that re-tapping after welding is not necessary

Nominal sizes

From DN15 to DN65

Thread sizes

From 1/2" BSP to 2 1/2" BSP

Material

316 stainless steel

If the type you need is not shown, please contact us

Weld-In Sockets

Nominal Size	Thread	Part No.
DN15	1/2" BSP	600/1030
DN20	3/4" BSP	653/1000
DN25	1" BSP	600/1025
DN40	1 1/2" BSP	600/1010
DN50	2" BSP	600/1017
DN65	2 1/2" BSP	600/1000

DIN11851 Weld-In Sockets



Specification

DIN11851 fittings are compatible with hygienic service conditions. A complete assembly includes a weld-in socket, a slotted nut and a silicone seal

Nominal sizes

DN50, DN65, DN80

Compatible parts

1 1/2", 2" and 2 1/2" relief valves

Material

Socket & nut: 316 stainless steel

Seal: Silicone

If the type you need is not shown, please contact us

DIN11851 Hygienic Fittings

Size	Weld Socket Part No.	Slotted Nut Part No.	Silicone Seal Part No.
DN50	176/2660	176/2670	176/2675S
DN65	176/2645	176/2630	176/2653S
DN80	176/2550	176/2650	176/2685S



Valve Repair and Maintenance Accessories & Spare Parts



We supply a range of special tools and repair kits to do scheduled maintenance and repair procedures to our valves.

We recommend that you use the correct special tools to help you do maintenance and repairs quickly and easily without causing damage to the valve or the new spare parts.

A selection of step-by-step maintenance instruction manuals is also available, please contact us.

CAUTION: Valve maintenance and repair can be dangerous. To do maintenance, you must have experience and qualifications related to valve installation on pressure vessels and systems.

Relief Valve Pressure/Vacuum Test Rig Part No: 400/8000



Specification

You can use the relief valve test rig to test the pressure and vacuum setting of Hyper Maxi, Super Maxi, Twinact, Uniact, Minnow and Steam relief valves.

Valve connection

2½" BSP: We supply adaptors to change to other BSP and flanged connections

Test rig supply connection

¼" BSP female socket

Test range

From -0.7 Bar to 6.9 Bar (-10 PSI to 100 PSI)

Related documents

Operating Instructions: OPIN26. Please contact us

Footvalve & Relief Valve Seat Repair Kit Part No: 3" Kit - 400/2600 Part No: 4" Kit - 400/2900



Specification

You can use the seat repair kit to re-surface the seating face of a valve if there is damage caused by corrosion.

Compatible

3" Kit: compatible with 2½" Super Maxi relief valve and 3" Cleanflow and Highlift footvalves

4" Kit: compatible with 4" Cleanflow & Highlift footvalves

Connection

Compatible with power tools with a ½" chuck

Kit contents

Selection of grinding and polishing discs

Selection of face-forming tools

Instruction manual

Related documents

Operating Instructions: 3" Kit OPIN70, 4" Kit OPIN77. Please contact us.

Spare Parts: Grinding Discs

Description	Part No. 3"	Part No. 4"
Box of 100 x 60 grit	400/2610	400/2615
Box of 100 x 80 grit	400/2620	400/2625
Box of 100 x 180 grit	400/2630	400/2635
Box of 100 x 500 grit	400/2640	400/2645



Valve Repair and Maintenance Accessories & Spare Parts



Relief Valve Tool Kits

Description	Part No.
Test rig adaptor flange: Adapts 2½" BSP to 3" ASA150, DIN65 PN10 & DIN80 PN6	425/1000
C spanner: To install/remove Twinact relief valves	400/3000
C spanner: To install/remove Super Maxi relief valves	400/3001
Tightening tool for MKIII Super Maxi relief valves	400/8380
Tool kit: 1½" & 2½" Twinact valves	400/1000
Tool kit: 65mm & 80mm Super Maxi & Hyper Maxi relief valves	400/8300



Footvalve Tool Kits

Description	Part No.
Tool kit: 3" Cleanflow footvalve	400/2150
Tool kit: 3" Highlift footvalve	400/2450



Ball Valve Tool Kits

Description	Part No.
Spindle O ring stuffing tool: 1½" MKIII airline ball valve - 530/type	FIX/A/0075/2
Tool kit: 1½" MKII airline ball valve - 353/type	400/2500
Tool kit: 3" ball valve spindle O ring tools - 360/5XXX type valves	400/2200STK
Tool kit: 3" ball valve - 360/0000 type valves, pre-2003	400/2200

Butterfly Valve Tool Kits

Description	Part No.
Tool kit: 2" butterfly valve	400/2300
Tool kit: 3" butterfly valve	400/2700



APPENDIX

Catalogue

A	Bolt Torque Guide & Step Loading Procedure
B	Client Responsibilities - Valves & Accessories

THIS PAGE IS INTENTIONALLY BLANK



Bolt Torque Guide & Step Loading Procedure

Installation & Operating Instructions

Flange Bolting

CAUTION: Weld-distortion and too much tightening force will cause damage to a flange.

It is important not to cause damage to weld-in flanges and mating flanges. If a flange is damaged it will not give a satisfactory seal when a gasket and secondary mating flange is installed.

Bolt-stress can decrease after initial tightening. The cause can be deformation of the gasket material, particularly with soft materials such as a CNAF/PTFE envelope gasket.

Best procedure recommends that, after initial bolting, the flange joint is tightened again after a period of time. Most gasket manufacturers advise a period of 24 hours. ASME PCC-1-2000 GUIDELINES FOR PRESSURE BOUNDARY BOLTED FLANGE JOINT ASSEMBLY advises a minimum period of 4 hours.

Bolt torque calculations are based on a flat flange to within 0.15mm.

Recommended bolt torque values will be reduced if a lubrication is used.

Bolt Torque

Bolt Torque Values

Fort Vale bolt torque values are given as a reference guide only and are based on:

- the use of a CNAF/PTFE gasket.
- unlubricated fasteners.
- a flange flat to within 0.15mm.

CAUTION: If you use a different gasket material, a lubricant or a flange with distortion, you must re-calculate the torque value.

Bolt Torque Procedure

To install flanged parts correctly:

- Examine the mating flange of the part.
- If the flange is marked with a torque value, obey that torque value.
- If there is no torque value marked on the mating flange, obey the bolt torque values given in Table BT1.
- Tighten the bolts evenly in sequence. Refer to Figure BT1.
- Obey the Step Loading Procedure (ASME PCC-1-2000). Refer to the next page.

Table BT1

Thread	Torque Value
M10	30 Nm (22 lbf.ft)
M12	65 Nm (48 lbf.ft)
M16	81 Nm (60 lbf.ft)

Figure BT1

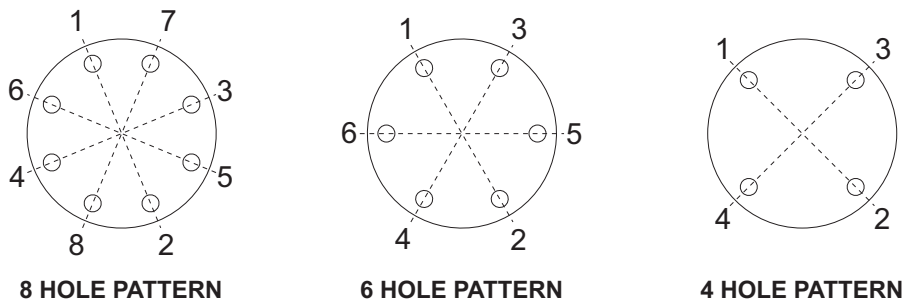



Bolt Torque Guide & Step Loading Procedure

Installation & Operating Instructions

Step Loading Procedure

To install flanged parts correctly, obey the Step Loading Procedure extract from ASME PCC-1-2000:

Install

Hand tighten, then “snug up” to 15 Nm (10 lbf.ft) to 30 Nm (20 lbf.ft) (not to exceed 20% of Target Torque). Check flange gap around circumference for uniformity. If the gap around the circumference is not reasonably uniform, make the appropriate adjustments by selective tightening before proceeding.

Round 1

Tighten to 20% to 30% of Target Torque. Check flange gap around circumference for uniformity. If the gap around the circumference is not reasonably uniform, make the appropriate adjustments by selective tightening before proceeding.

Round 2

Tighten to 50% to 70% of Target Torque. Check flange gap around circumference for uniformity. If the gap around the circumference is not reasonably uniform, make the appropriate adjustments by selective tightening before proceeding.

Round 3

Tighten to 100% of Target Torque. Check flange gap around circumference for uniformity. If the gap around the circumference is not reasonably uniform, make the appropriate adjustments by selective tightening before proceeding.

Round 4

Continue tightening the bolts, but on a rotational clockwise pattern until no further nut rotation occurs at the Round 3 Target Torque value. For indicator bolting, tighten bolts until the indicator rod retraction readings for all bolts are within the specified range.

Round 5

Time permitting, wait a minimum of 4 hr and repeat Round 4; this will restore the short-term creep relaxation/embedment losses. If the flange is subjected to a subsequent test pressure higher than its rating, it may be desirable to repeat this round after the test is completed.



Client Responsibilities - Valves & Accessories

Installation, Operation & Maintenance Instructions

Compatibility

Make sure that the function and technical specification of the valve/accessory is compatible with the vessel service conditions and the cargo. This includes, but is not limited to:

- dimensions.
- pressure/vacuum setting.
- air/vapour/liquid flow capacity.
- maximum allowable working pressure.
- test pressure.
- minimum/maximum design temperatures.
- materials of construction.

Maintenance and Inspection

Fort Vale valves and accessories have a long life if you use them correctly in compatible service conditions. It is not necessary to lubricate the parts, but we recommend that you do the inspections that follow:

Inspections at regular intervals:

1. Examine the valve to make sure there is no damage, wear or corrosion.
2. Examine the valve and adjacent area to make sure there is no leakage of cargo.
3. Examine the fasteners to make sure they are not loose.
4. Make sure the valve operates correctly.

CAUTION: If you operate the valve with very corrosive cargo, or near its temperature and/or pressure limit (very high or very low temperature and/or pressure), do the inspections more frequently.

Also, schedule regular maintenance based on how frequently the valve is used, the type of cargo and the service conditions.

Inspections after 2½ years of service or a minor incident:

1. Examine the valve to make sure there is no damage, wear or corrosion.
2. Make sure the valve operates correctly.
3. Do a pressure test on the valve.

Inspections after 5 years of service or a major incident:

1. Disassemble and clean the valve.
2. Replace all the valve seals and do a pressure test.

Replacement Parts

Do not adapt or change the valve. If you install a replacement part, it must be a genuine Fort Vale part.

WARNING: If you install a part that is not genuine, there is a risk of:

- injury to personnel.
- permanent damage to the valve.
- permanent damage to the vessel.
- valve malfunction.

External Fire

If you install the valve in an area where there is a risk of external fire, you must install compatible accessories to prevent damage to the valve.

Compatibility of Accessories

Accessory components must cause no interference with the valve's function. Accessories must be made from compatible materials that will cause no damage to the valve materials. Do not install an accessory that will cause an increased load on the valve, such as mechanical, static, dynamic or thermal load.

Mis-use

Obey the instructions and recommended procedures in the installation and operating instructions. Obey the pressure and temperature markings on the valve and on the drawing. Use the valve/accessory for its correct function only. Fort Vale accept no liability or responsibility for incorrect use of the valve/accessory.

THIS PAGE IS INTENTIONALLY BLANK



Our subsidiaries are located in:

US Office

126 N. Virginia
La Porte
TX 77571
USA

Tel: +1 281 471 8100

Fax: +1 281 471 8116

Email: ussales@fortvale.com

Head Office

Calder Vale Park
Simonstone Lane
Simonstone, Burnley
Lancashire, BB12 7ND, UK

Tel: +44 (0) 1282 687120

Fax: +44 (0) 1282 687110

Email: sales@fortvale.com

China Office

Fort Vale Engineering Shanghai Ltd
Building 11 88 Yuanshan Road
Xinzhuang Industry Park
Shanghai 201108 China

Tel: +86 21 6442 1367

Fax: +86 21 6442 1376

Email: cnsales@fortvale.com

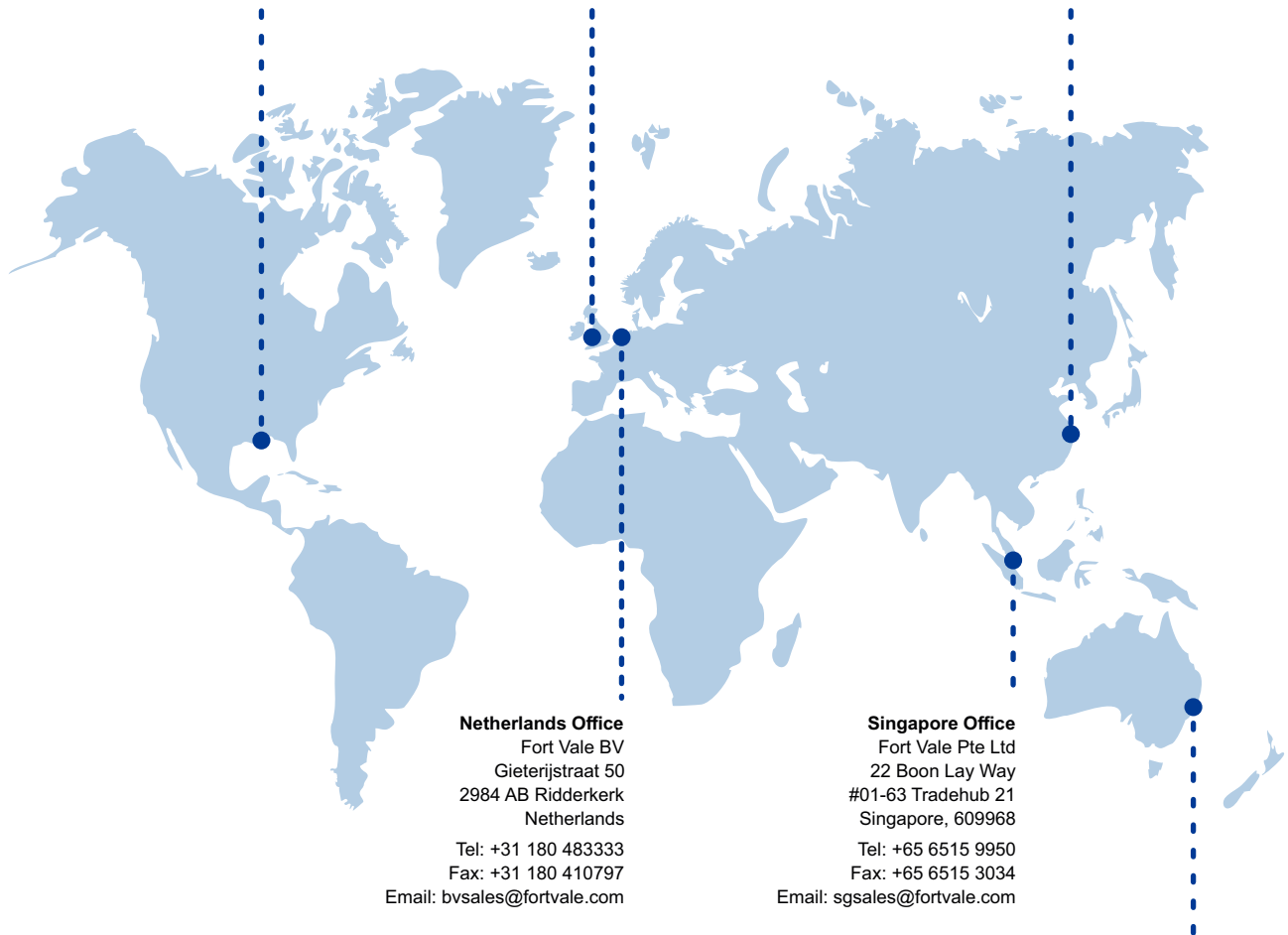

Netherlands Office

Fort Vale BV
Gieterijstraat 50
2984 AB Ridderkerk
Netherlands

Tel: +31 180 483333

Fax: +31 180 410797

Email: bvsales@fortvale.com

Singapore Office

Fort Vale Pte Ltd
22 Boon Lay Way
#01-63 Tradehub 21
Singapore, 609968

Tel: +65 6515 9950

Fax: +65 6515 3034

Email: sgsales@fortvale.com

Australia Office

Fort Vale Australia Pty Ltd
Bellwood Business Park
Unit 14, 49 Bellwood Street
Darra, Queensland, 4076

Tel: +61 7 3189 5059

Email: ausales@fortvale.com

We also have Authorised Distributors around the world to provide you with product sales and after-market services. To find your nearest distributor, please visit our website - www.fortvale.com

